

PG160-B02

8GB GDDR6, 256b, X16 Tall DVI-D + USBC/DP + DP + HDMI/DP + DP

TABLE OF CONTENTS

Page	Description
1	Table of Contents
2	Block Diagram
3	PCI Express
4	PCIE RC TERM
5	MEMORY: GPU FB_AB
6	MEMORY: FBA[31:0]
7	MEMORY: FBA[63:32]
8	MEMORY: FBB[31:0]
9	MEMORY: FBB[63:32]
10	MEMORY: GPU FB_CD
11	MEMORY: FBC[31:0]
12	MEMORY: FBC[63:32]
13	MEMORY: FBD[31:0]
14	MEMORY: FBD[63:32]
15	GPU PWR & GND
16	GPU Decoupling
17	GPU Decoupling2
18	IO: IFPAB DVI-D-DL
19	IO: IFPE DP
20	IO: IFPF USBC
21	IO: IFPC HDMI/DP
22	IO: IFPD DP
23	IO: NVHS Interface and Frame Lock
24	MISC1: Thermal, JTAG, GPIO,STEREO
25	MISC2: ROM, XTAL,STRAPS

Page	Description
26	PS: 1V8_PLL, 1V8_AON
27	PS: 5V
28	PS: PEXVDD
29	PS: FBVDDQ
30	PS: FBVDDQ PH2
31	PS: NVVDD Controller
32	PS: NVVDD Controller OVR3i
33	PS: NVVDD Phase 1,2
34	PS: NVVDD Phase 3,4
35	PS: NVVDD Phase 5,6
36	PS: Input Power Balancing Switcher
37	PS: Input, Filtering, and Monitoring
38	PS: STEERING, UPB & HOT-UNPLUG
39	PS: Type-C BuckBoost
40	PD PPC
41	PS: 12V & 3V3_A SWITCHER
42	SEQ: 5V, 1V8, NV3V3 ENABLE
43	SEQ: NV, PEX, FB ENABLE
44	SEQ: VOLTAGE MONITOR
45	SEQ: DISCHARGE
46	SEQ: MISC
47	LOGO LED
48	LED DRIVER & BOOST
49	DUAL FAN
50	PS: Pre-filter

Page	Description
51	MECH
52	PTC
53	Power Delivery
54	LED_CONTROLLER_IT8295

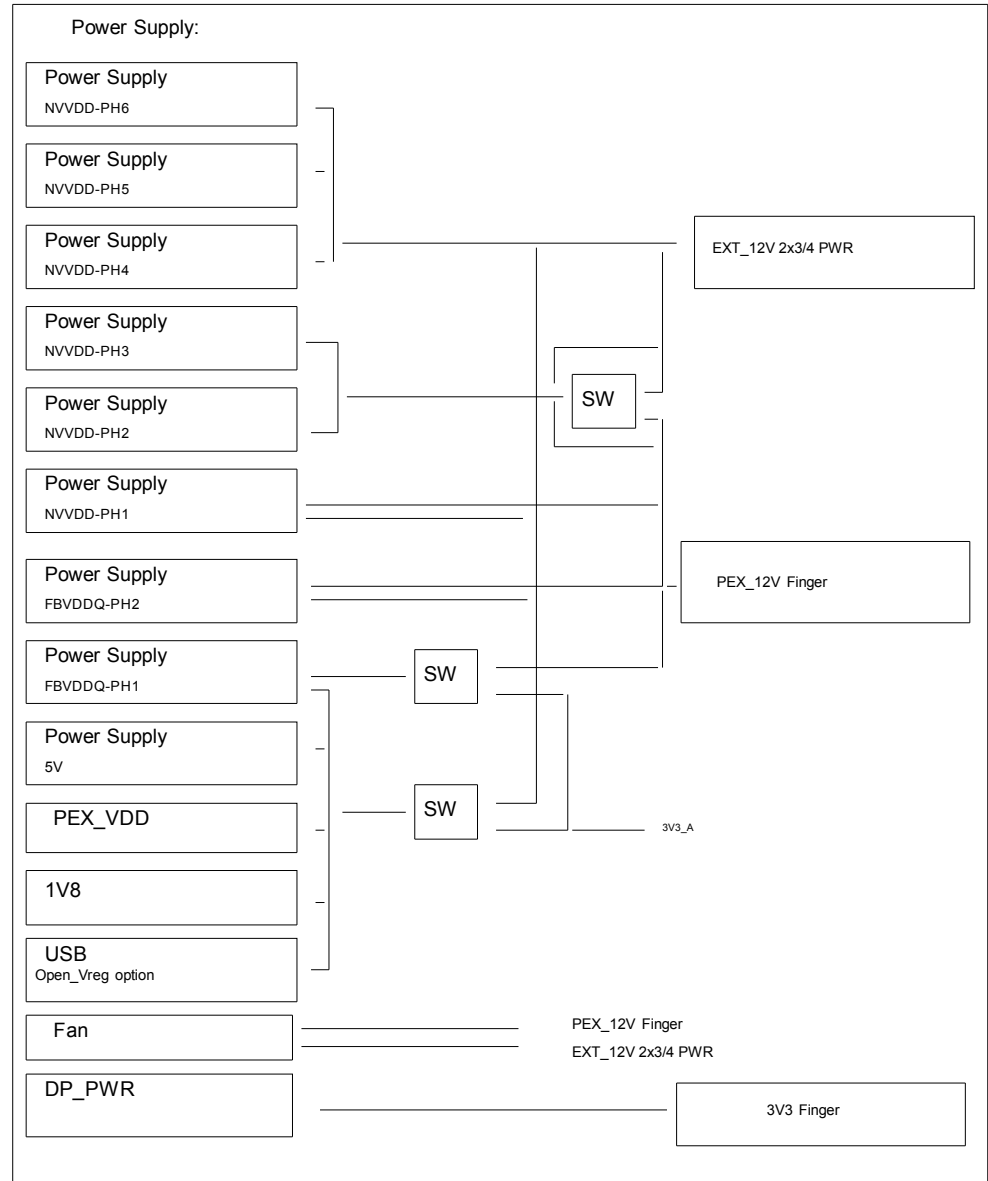
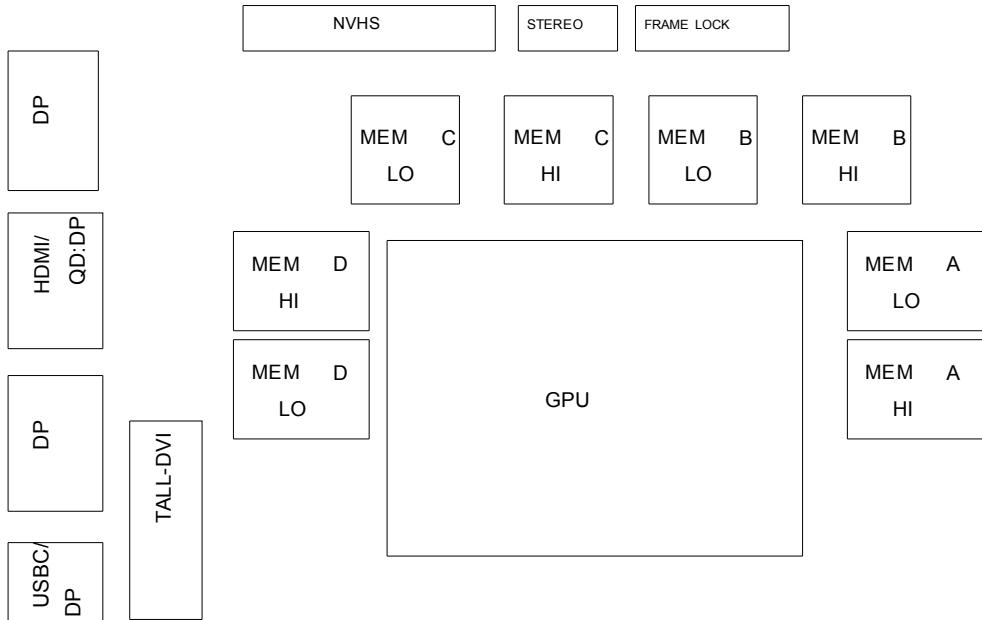

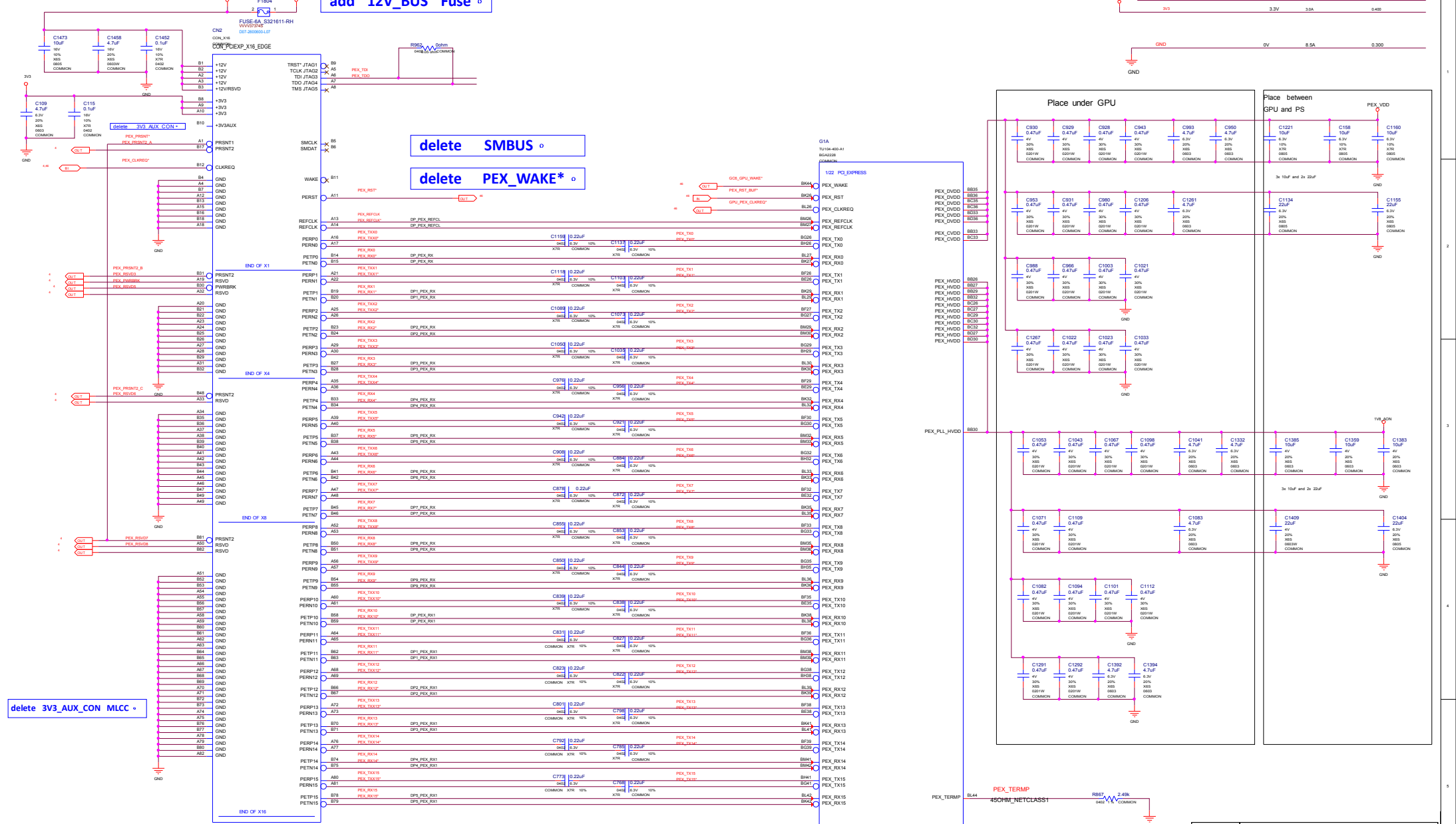

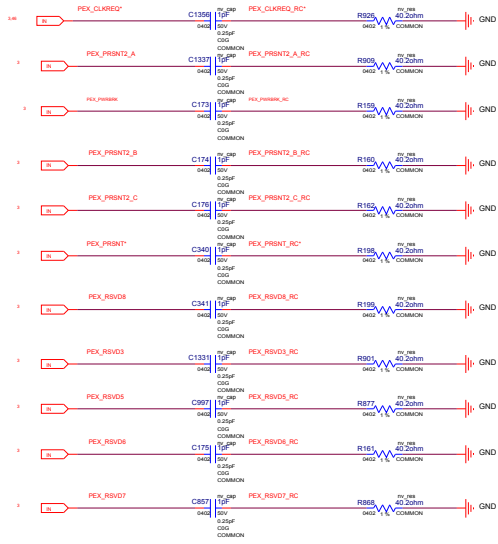

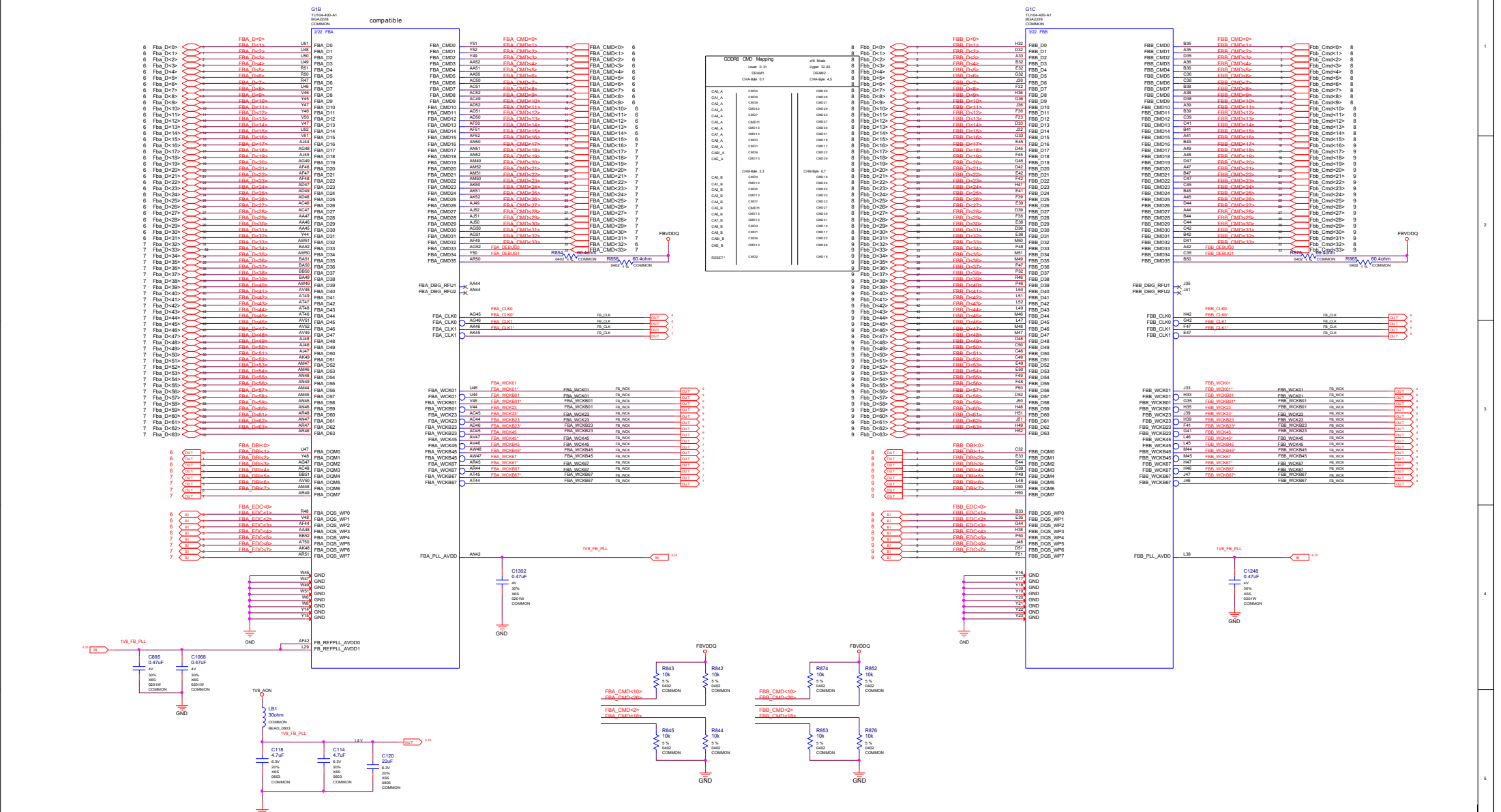

MICRO-STAR INT'L CO.,LTD
MS-V375

Size	Document	Description	Rev
Custom	MEMORY: GPU Partition A/B		4.0
Date: Fri, Nov 09, 2018		Sheet: 5 of 54	

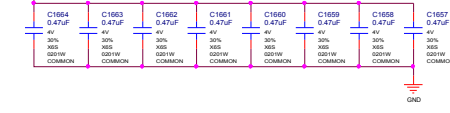
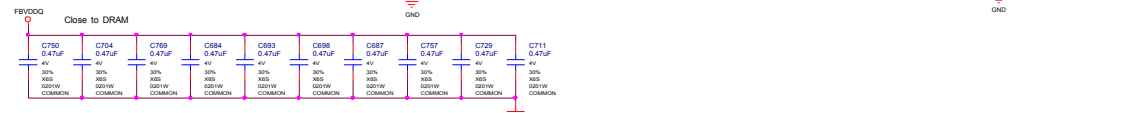
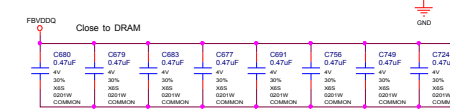
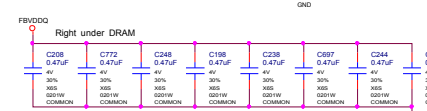
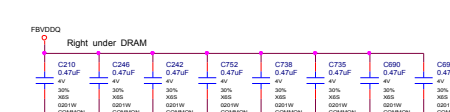
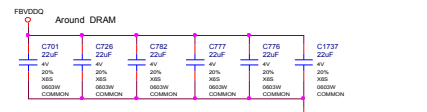
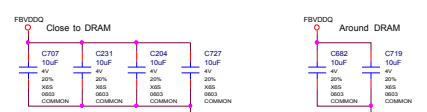
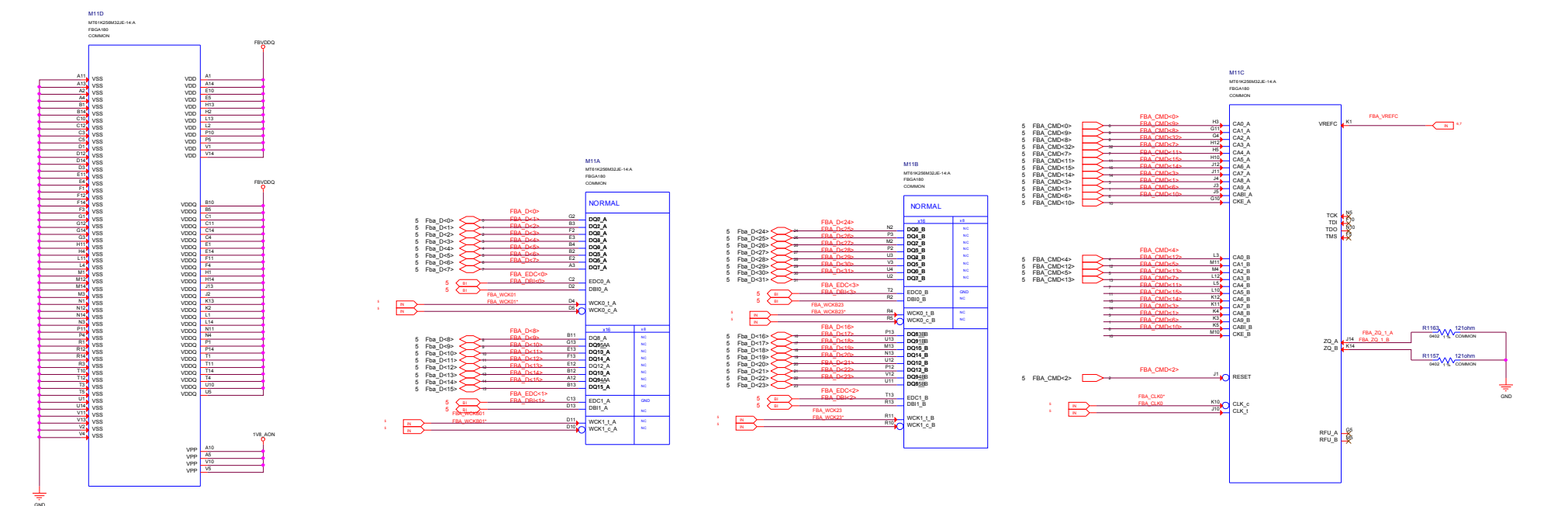

VREFC IS NOT USED IN x16 CONFIGURATION
1K OHM PULL-DOWN IS IN PLACE OF THE 1.33K FOR R106

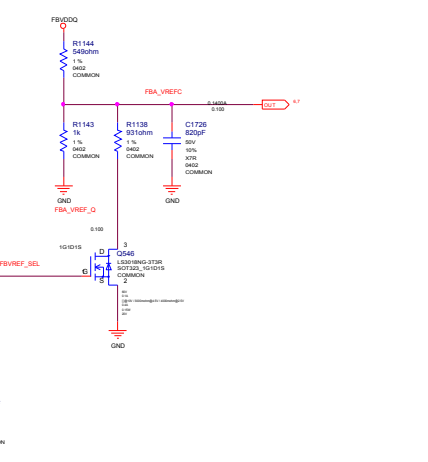

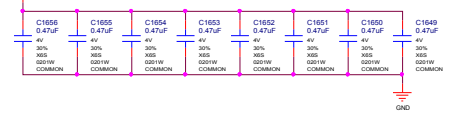
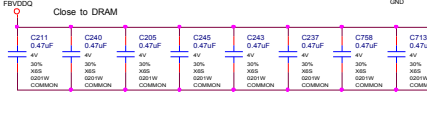
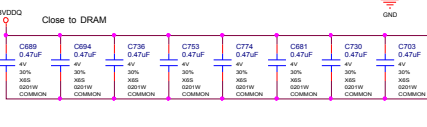
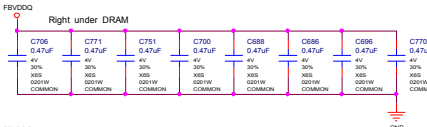
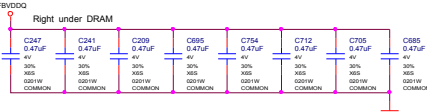
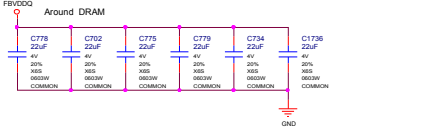
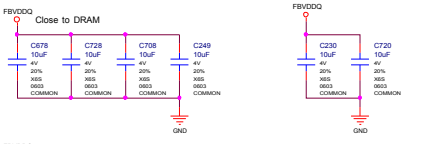
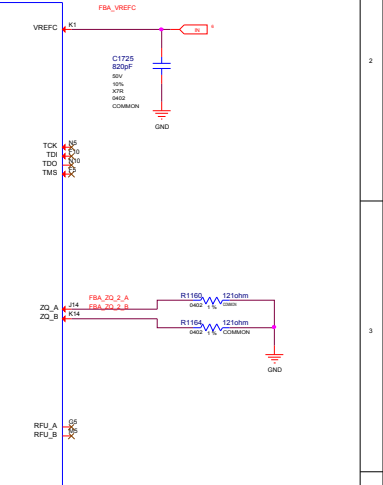
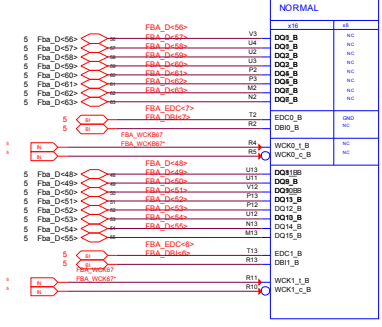
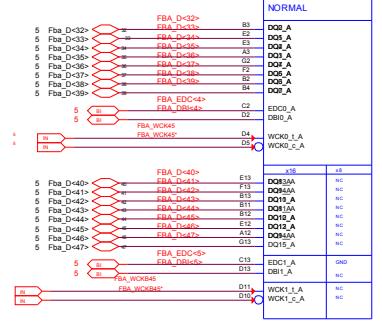
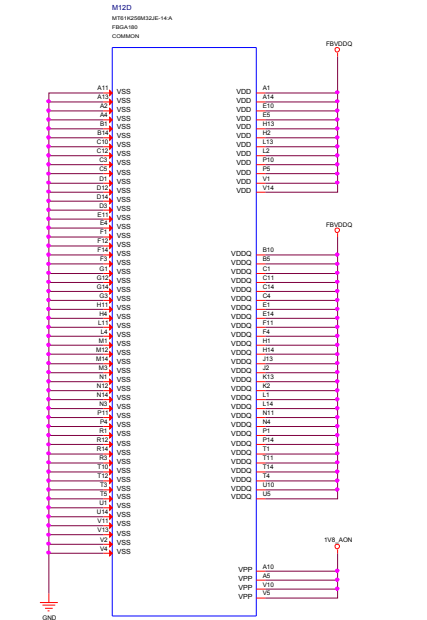

MICRO-STAR INT'L CO.,LTD
MS-V375

Size	Document	Description	Rev
Custom	MEMORY: FBA Partition 63..32		4.0
Date: Friday, November 09, 2018	Sheet	7 of 54	

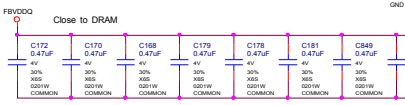
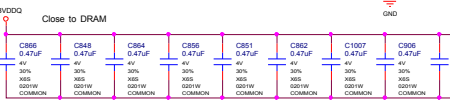
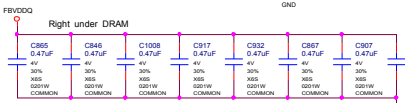
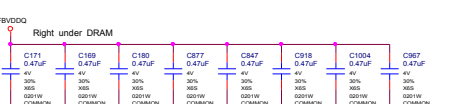
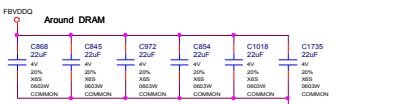
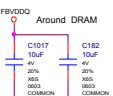
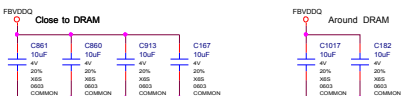
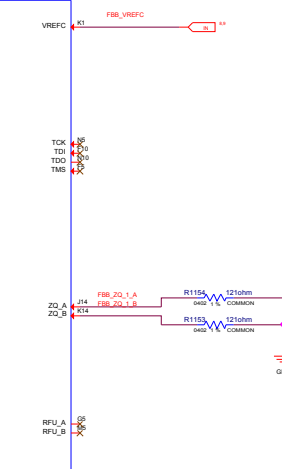
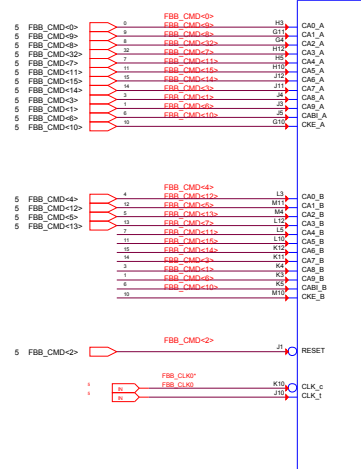
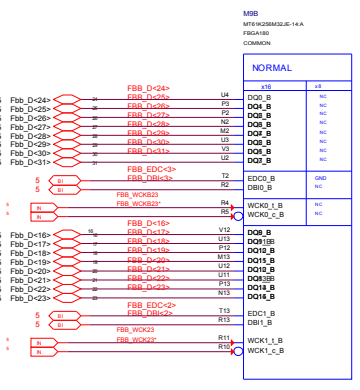
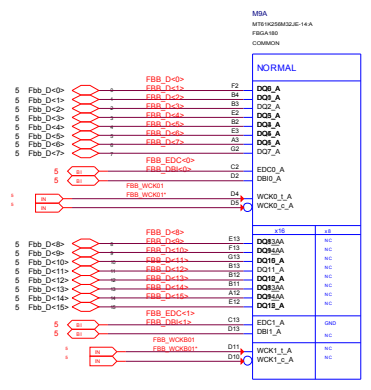
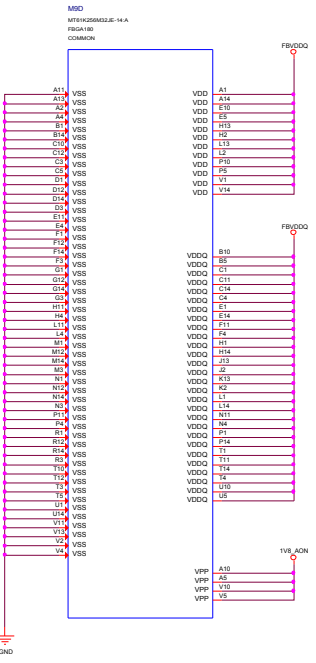

VREFC IS NOT USED IN x16 CONFIGURATION 1K OHM PULL-DOWN IS IN PLACE OF THE 1.33K FOR R104

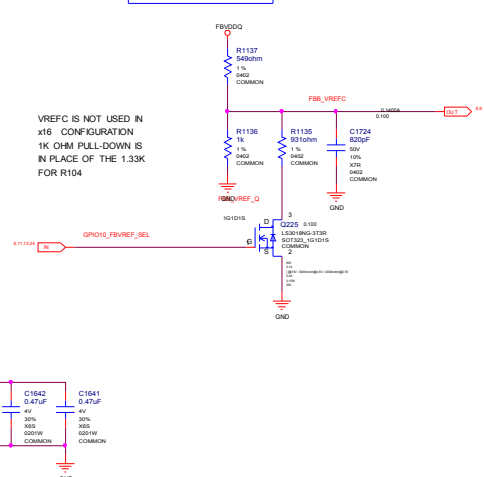

MICRO-STAR INT'L CO.,LTD MS-V375 Rev 4.0 Date: Friday, November 09, 2018 Sheet 8 of 54

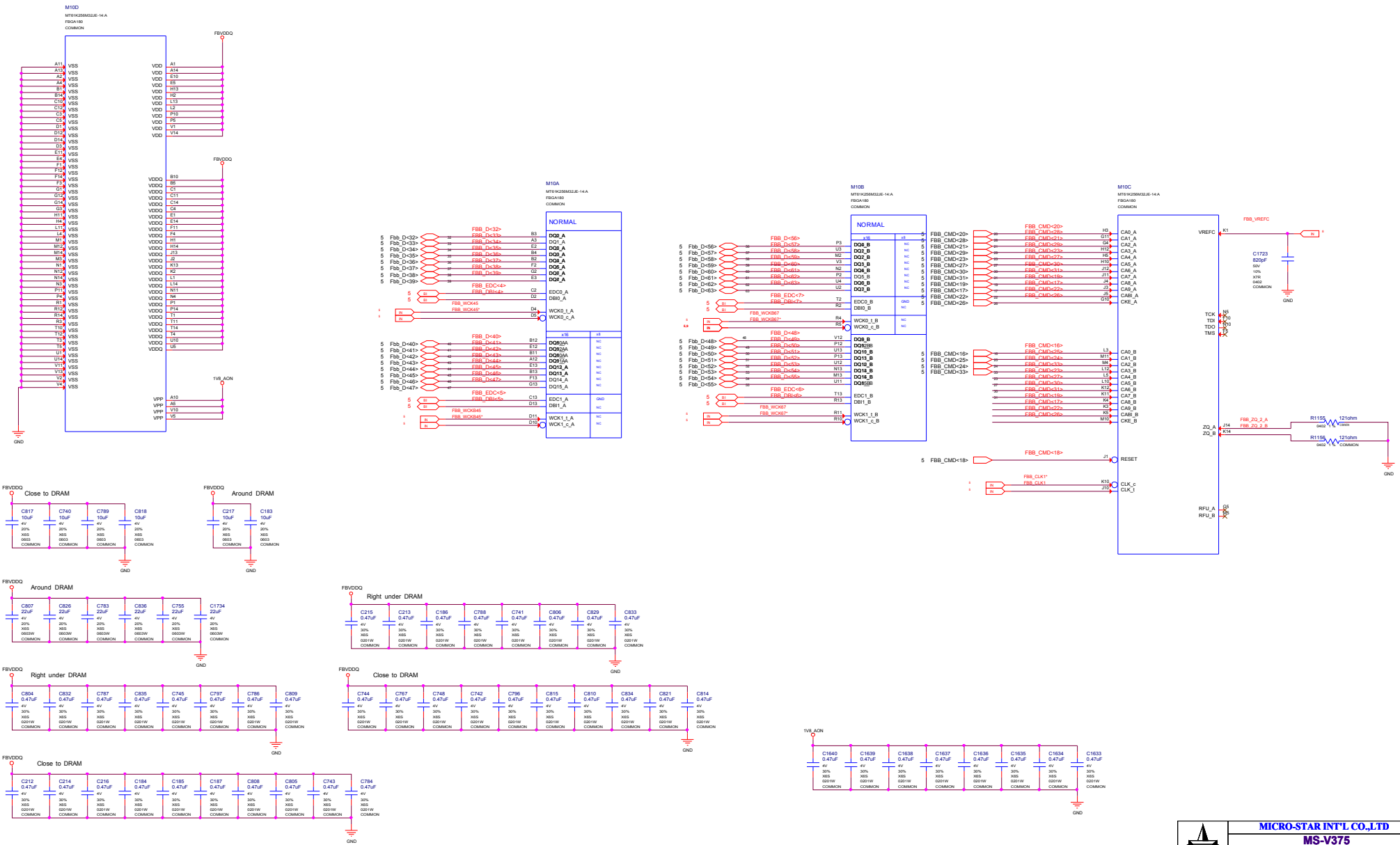

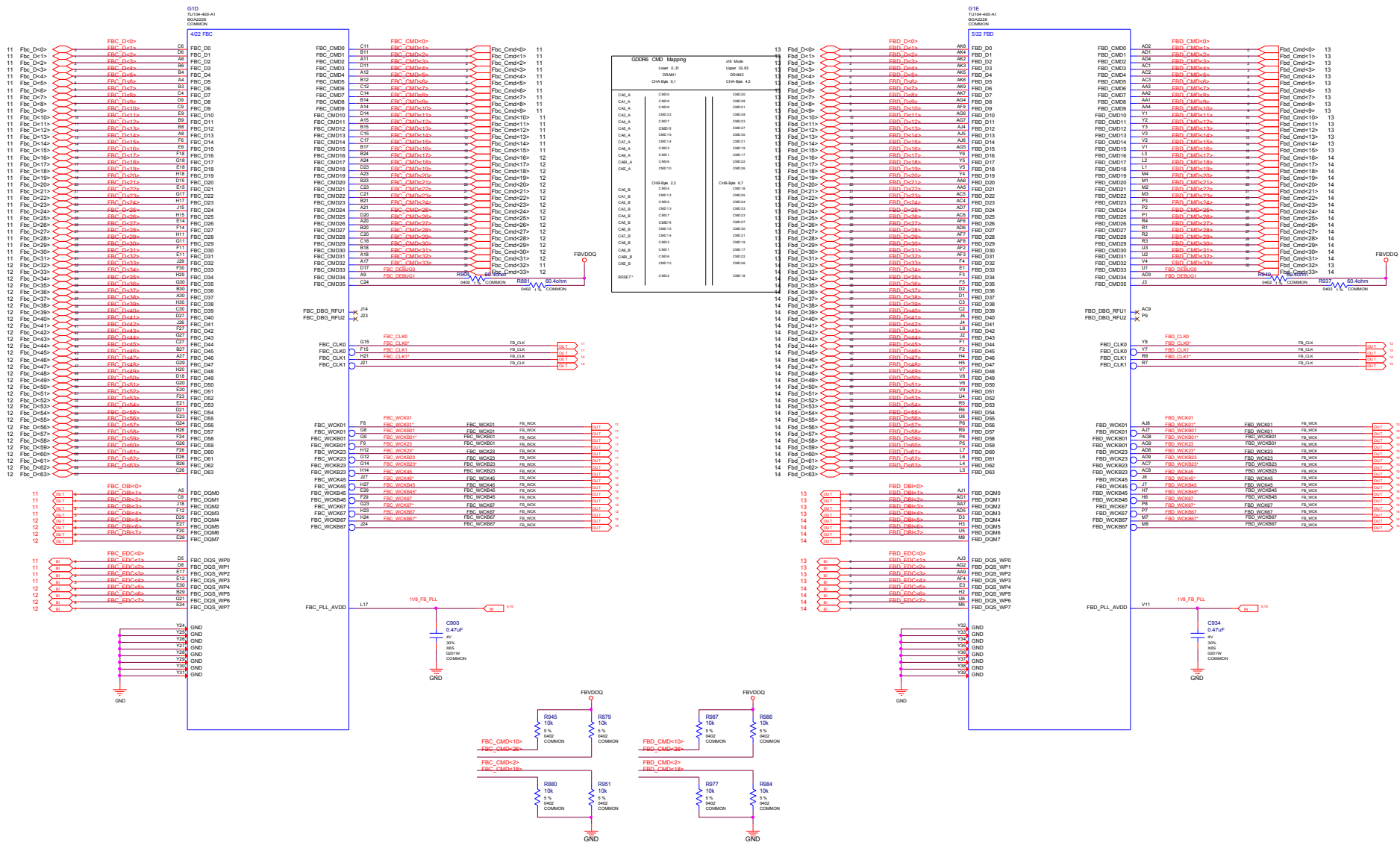

MICRO-STAR INT'L CO.,LTD
MS-V375

Size: Custom | Document Description: MEMORY: GPU Partition C/D | Rev: 4.0
 Date: Friday, November 09, 2018 | Sheet: 10 of 64

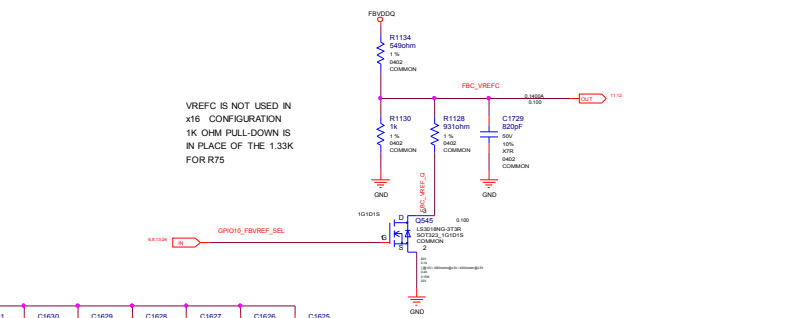
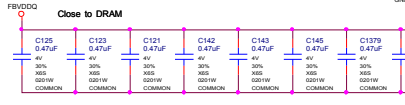
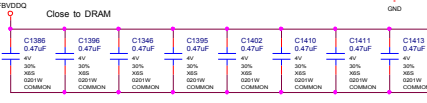
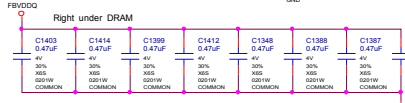
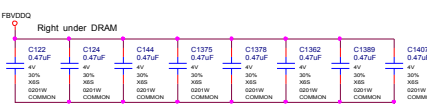
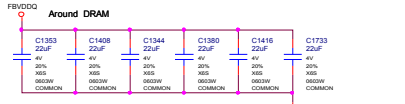
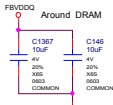
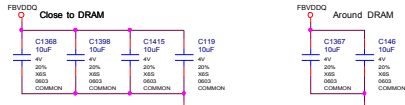
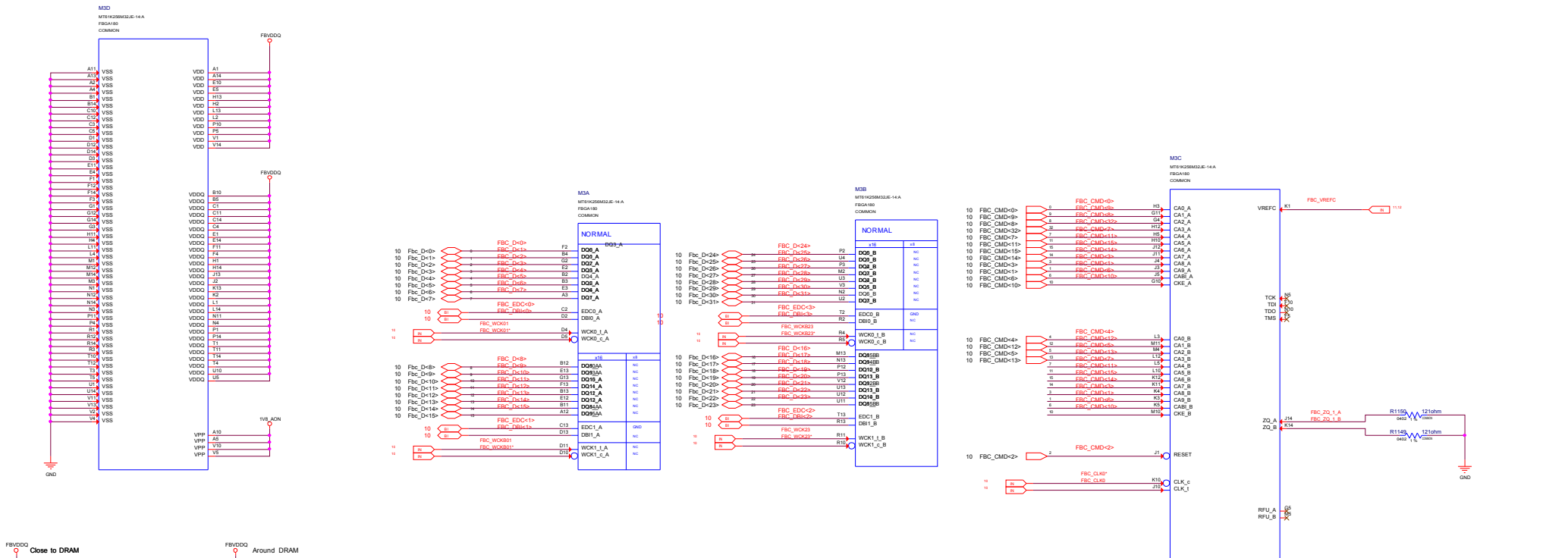

		MICRO-STAR INT'L CO.,LTD MS-V375	
Size	Document Description	Date:	Rev
Custom	MEMORY: FBC Partition 31.0	Friday, November 09, 2018	4.0
		Sheet	11 of 64

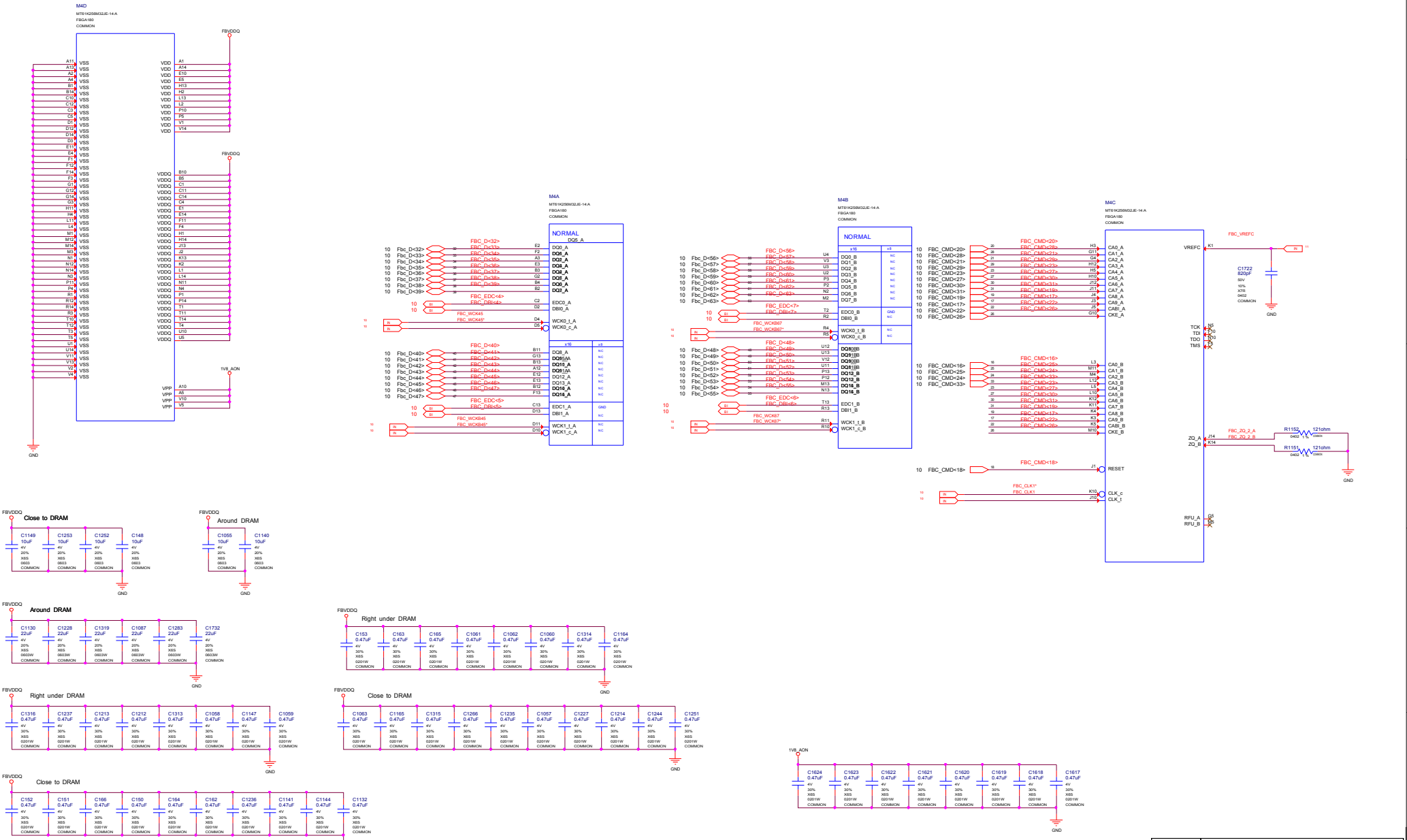

		MICRO-STAR INT'L CO.,LTD		Rev 4.0
		MS-V375		
Size Custom	Document Description	MEMORY: FBC Partition 63.32		Date : Fri, Nov 09, 2018
Page 12 of 54				

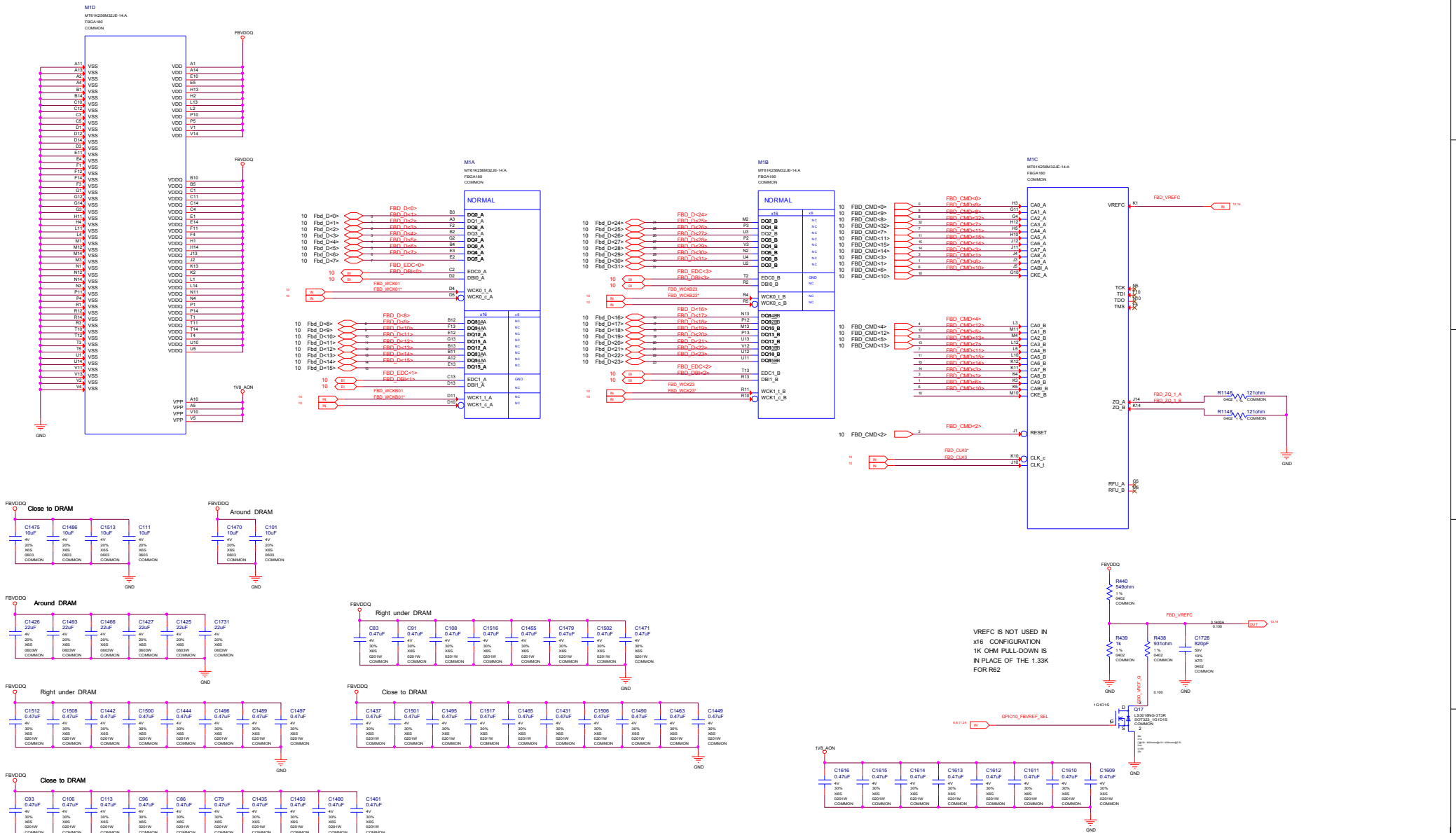

VREFC IS NOT USED IN X16 CONFIGURATION IN PLACE OF THE 1.33K FOR R62

		MICRO-STAR INT'L CO.,LTD MS-V375	
		Size: Custom Document: MEMORY: FBD Partition 31.0 Date: Friday, November 09, 2018	Description: MEMORY: FBD Partition 31.0 Rev: 4.0 Sheet: 13 of 64

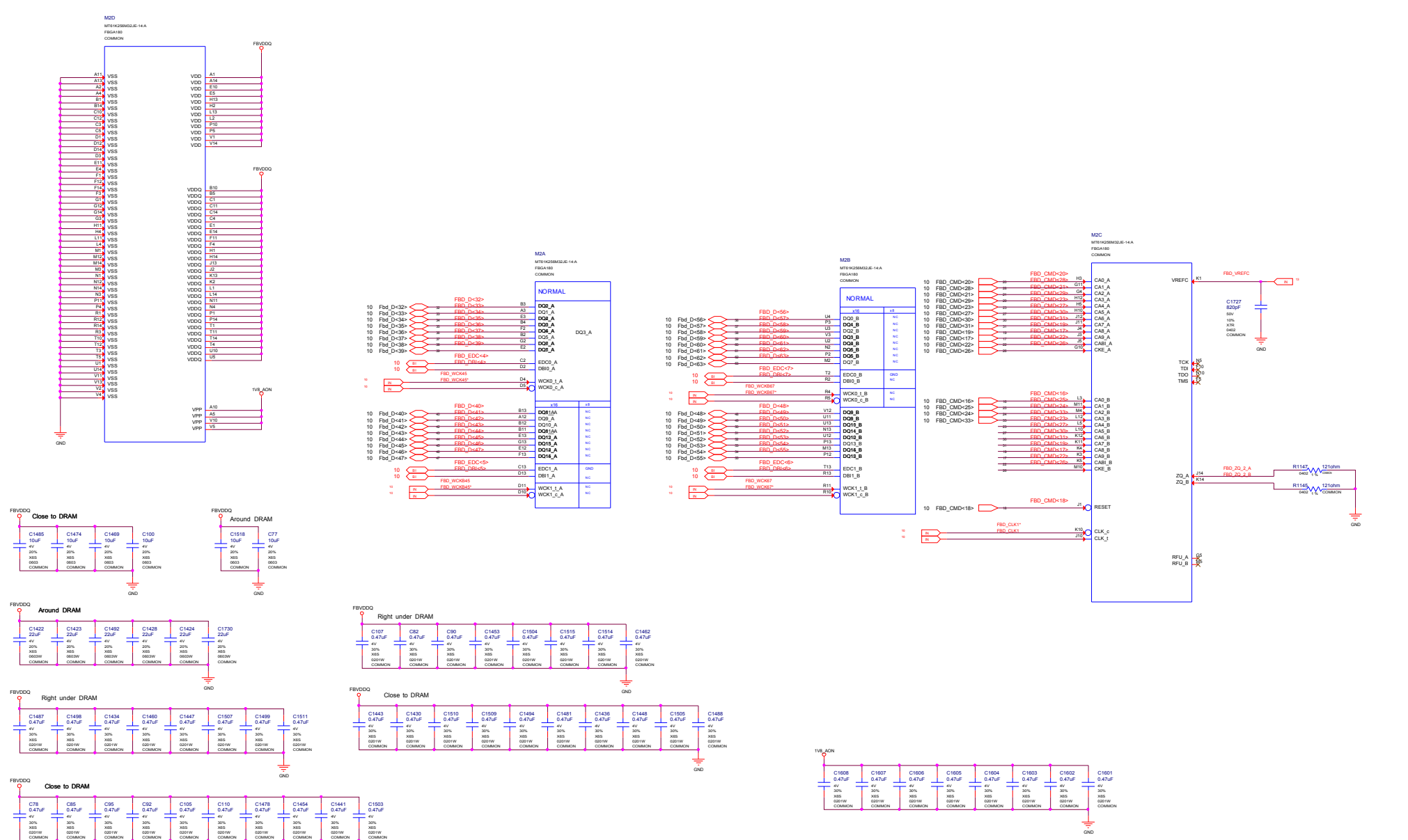

FBVDDQ

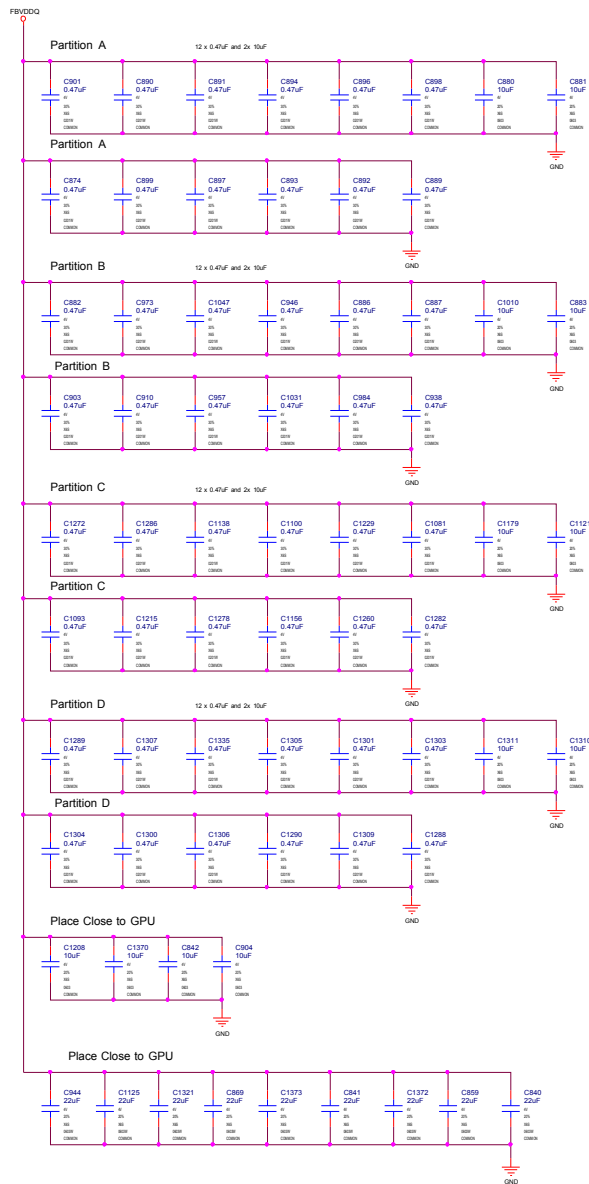

Under GPU

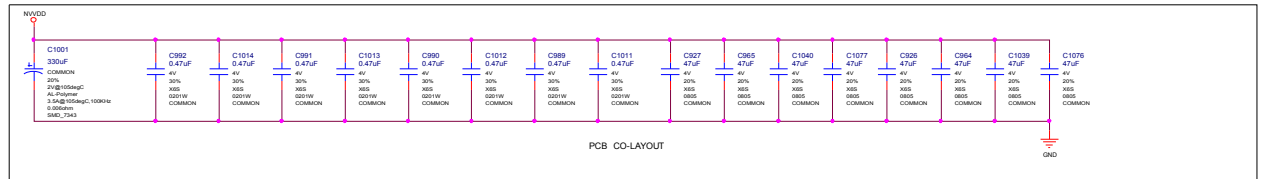
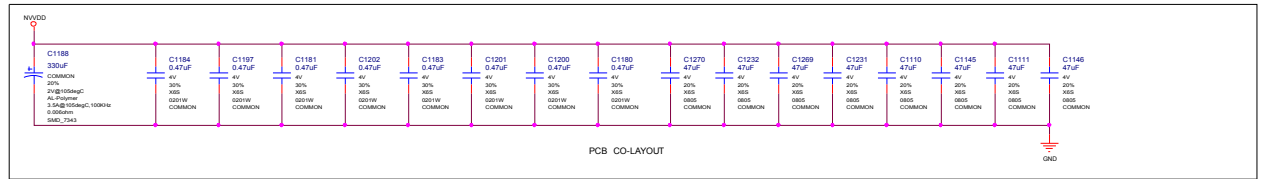

Near GPU

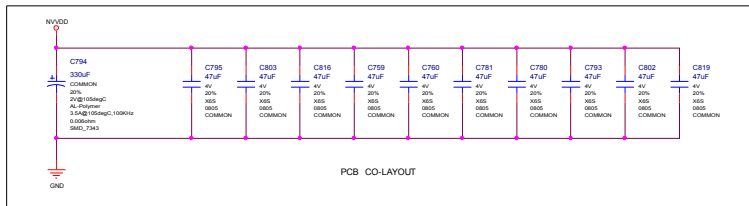
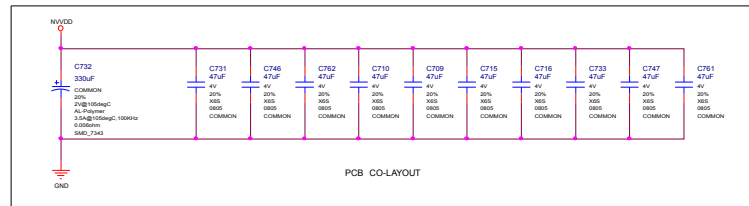
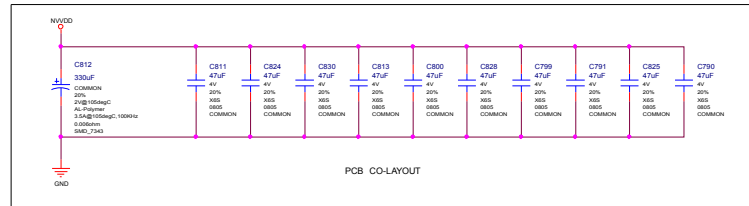

1V8_AON

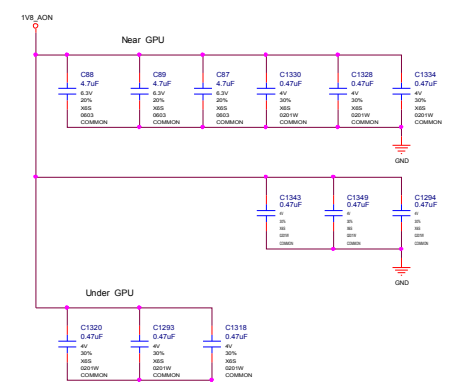

NVDD

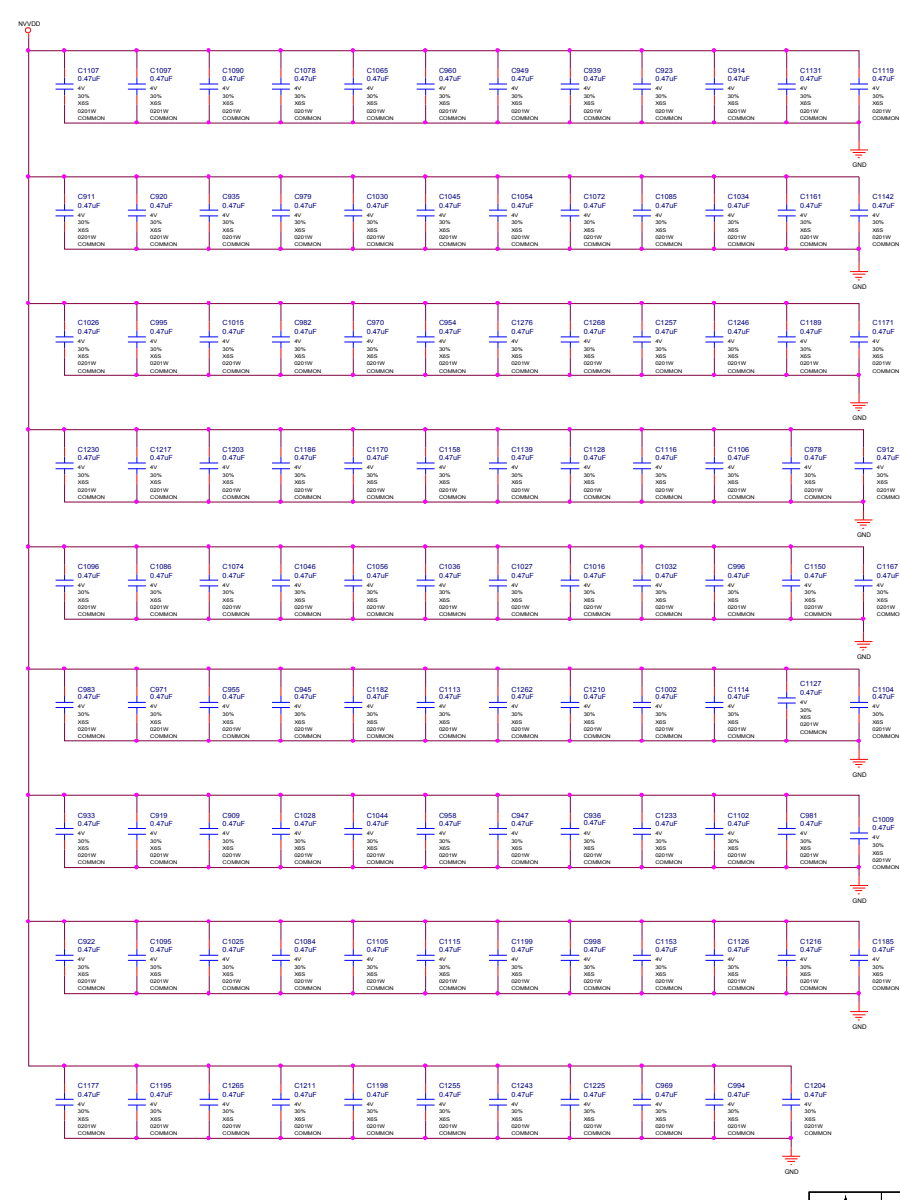
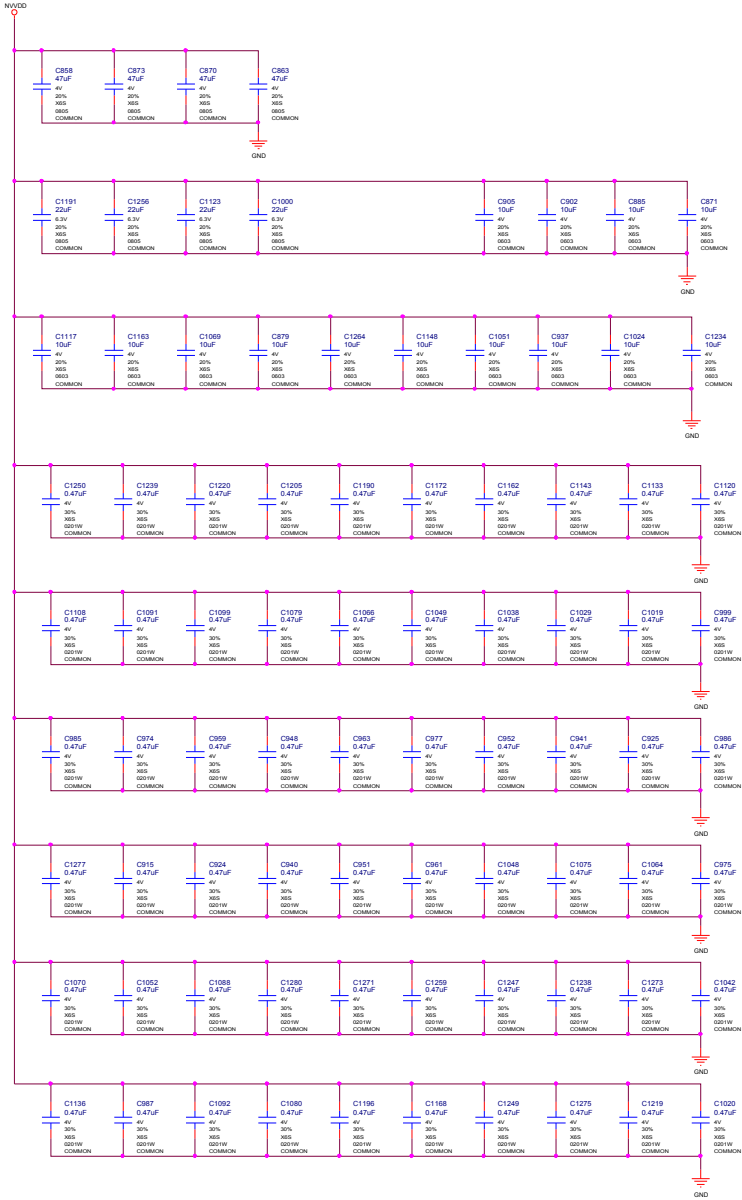

delete Link AB ◦

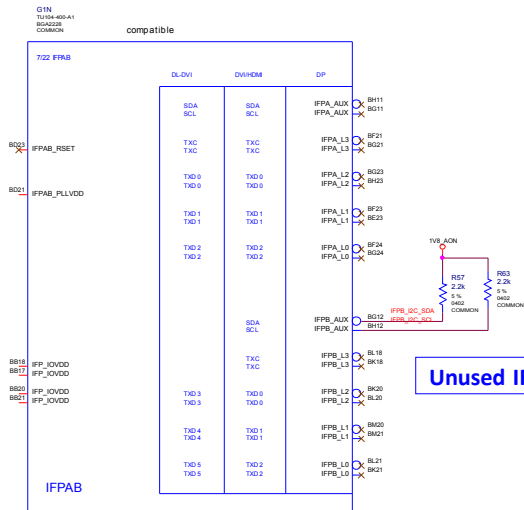

9.3 UNUSED PINS

If an IFP link is unused, in general it should be left unconnected. This includes Main and Aux links. IFPxy_RSET and IFPxy_PLLVDD (xy=AB,CD,EF) can be left unconnected if neither of IFPx /IFPy is in use. For example, **If neither link of the IFPA/IFPB macro is to be used, then IFPAB_PLLVDD and IFPAB_RSET should be left disconnected, and all signals and references associated with Link A and Link B should also be left unconnected.**

IFP_IOVDD rail can be unconnected if no IFP link is used. If any IFP is used, all IFP_IOVDD balls must be connected to power rail.

Unused IFPB_I2C* leaving Pull high resistor to 1.8V ◦

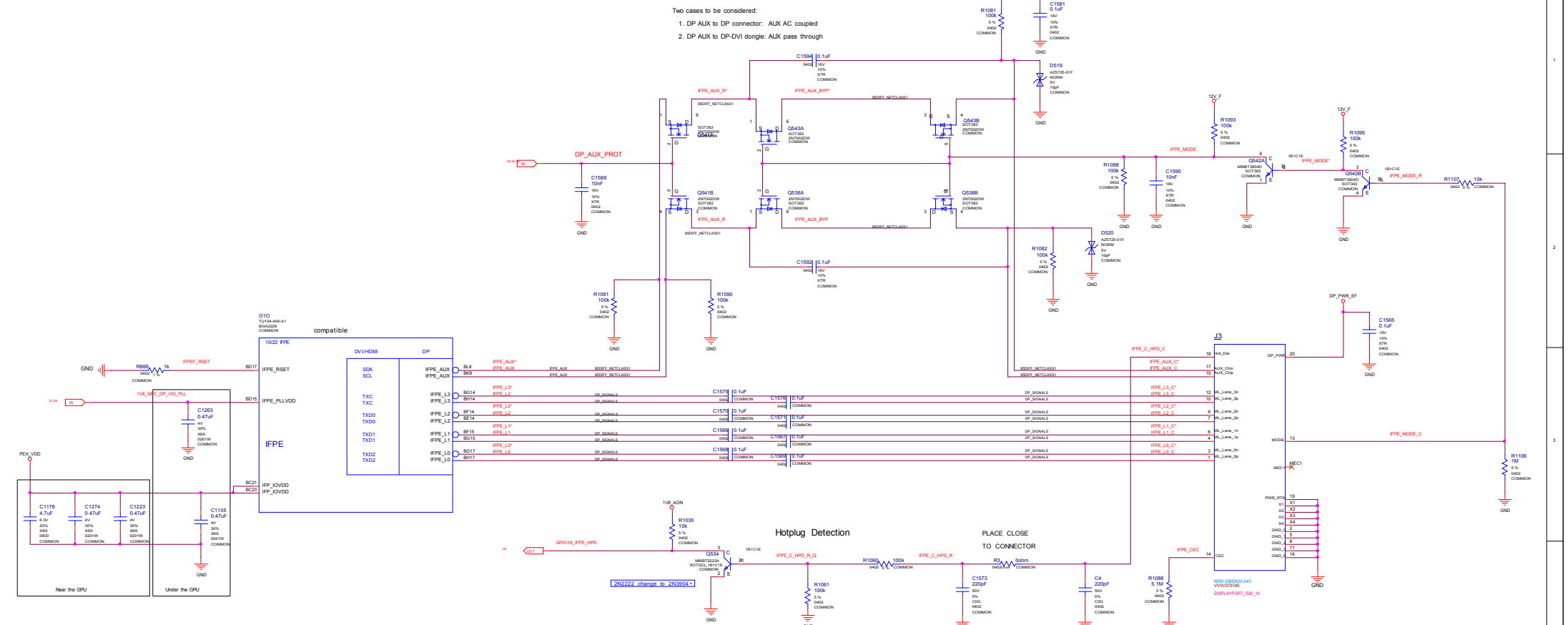

used V328-3.0 DP symbol

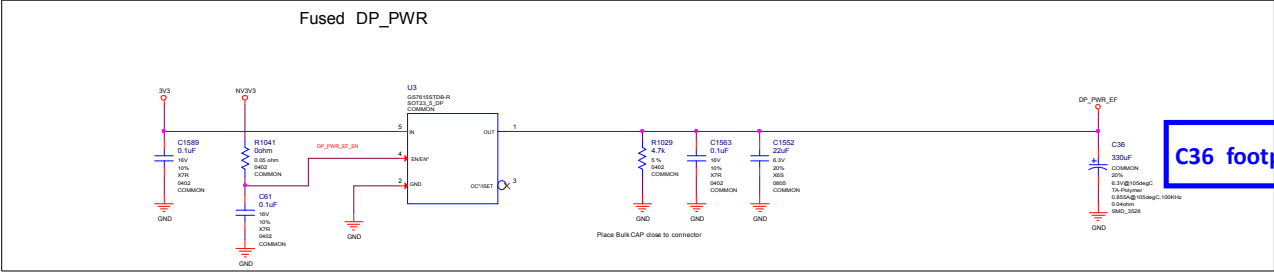

- 1 used V328-3 0 HD M sy mbd
- 2 HD M PN N5Y-1 9M058D - V0
- 3 ddt e DP
- 4 ddt e DP_P WR_CD and merged to DP_P WR_EF

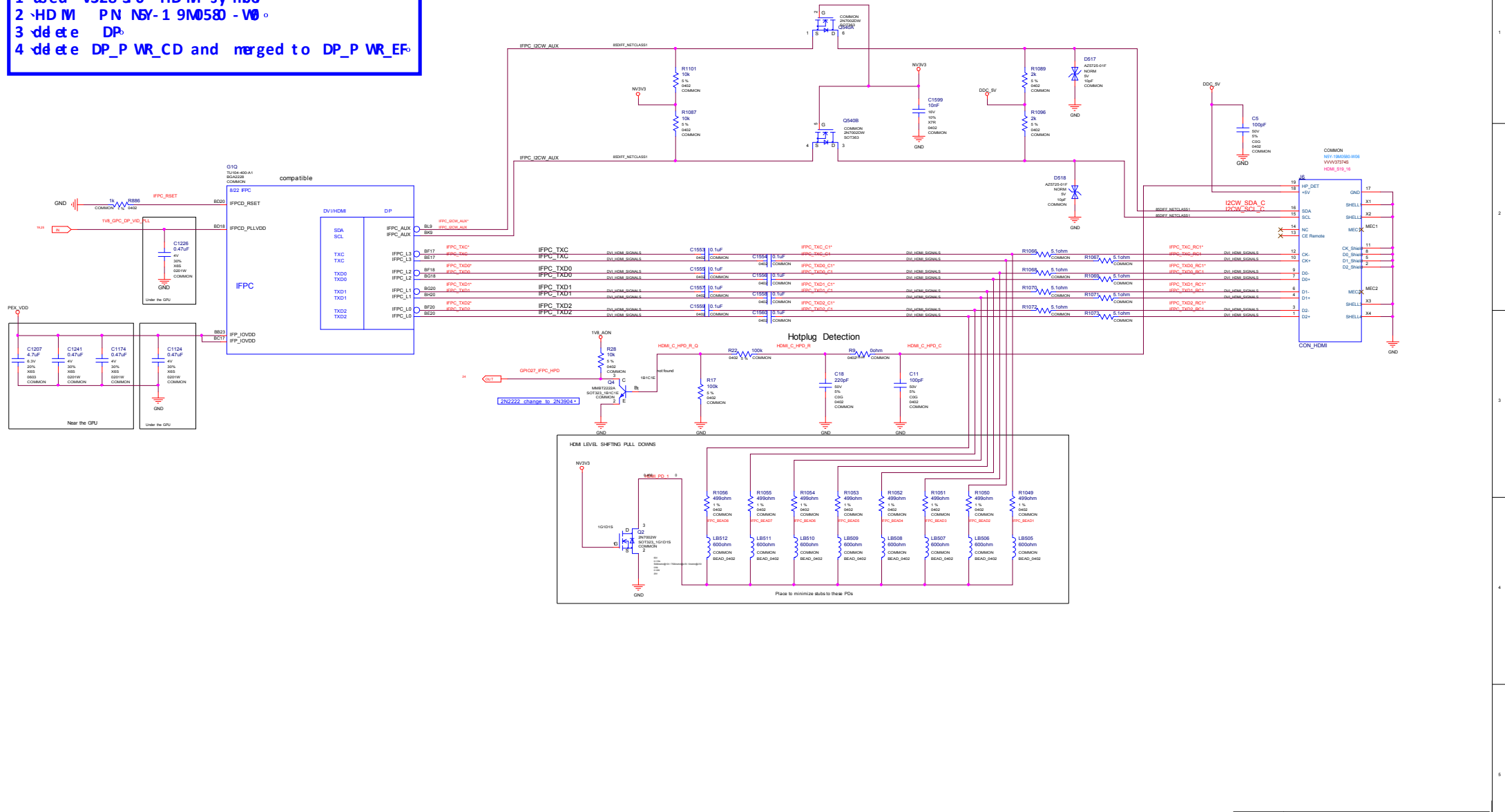

- Two cases to be considered:
1. DP AUX to DP connector: AUX AC coupled
 2. DP AUX to DP-DVI dongle: AUX pass through

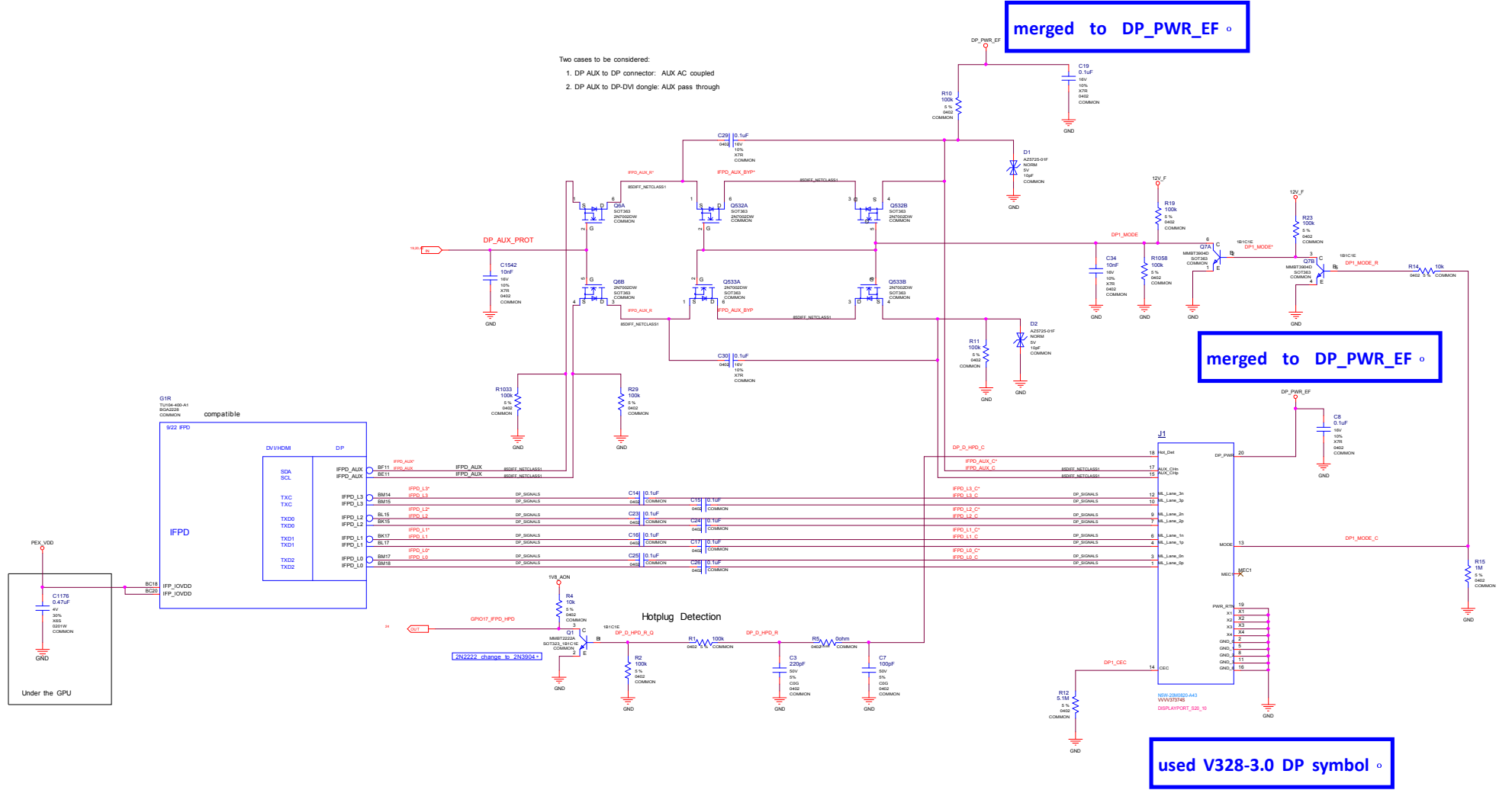

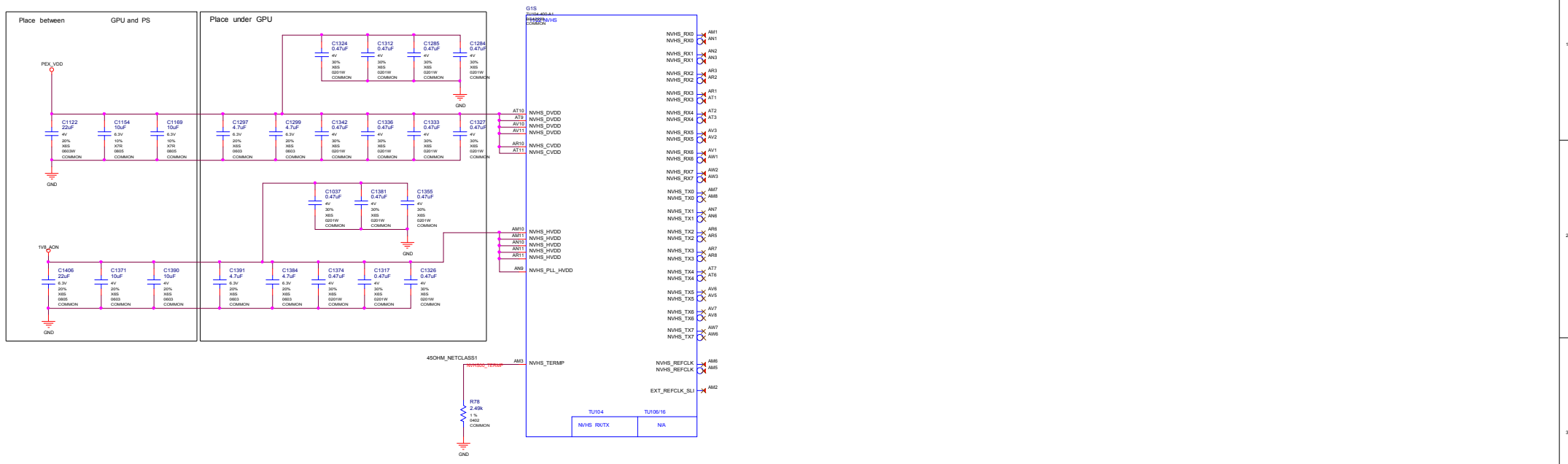

delete Frame Lock ◦

14.5 UNCONNECTED SIGNALS (NC)

Leave the THERMDP and THERMDN pins unconnected.

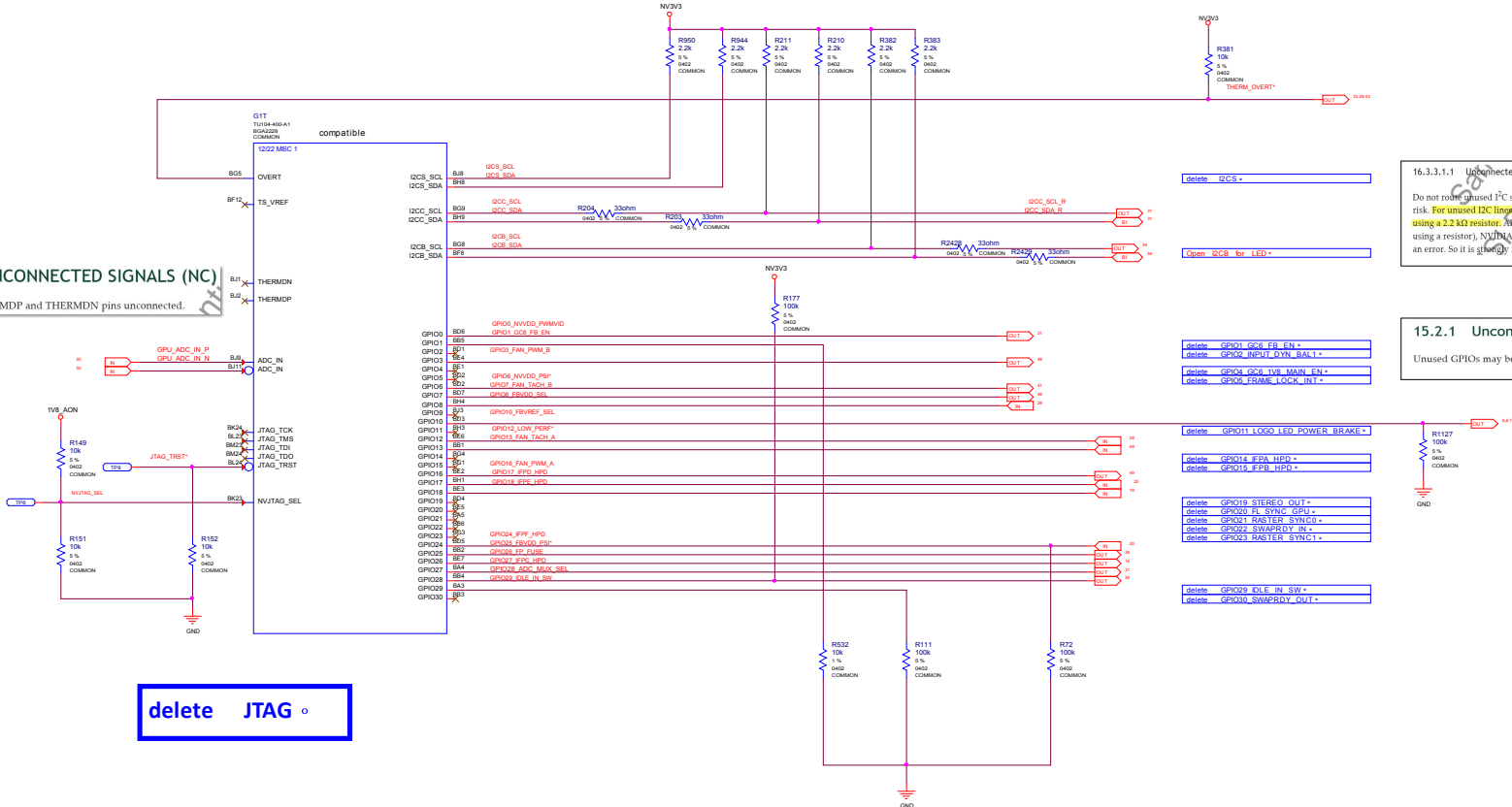

delete JTAG

Unused delete GPIO11_LOGO_LED_POWER_BRAKE

16.3.3.1.1 Unconnected I2C Pins
Do not route unused I2C signals on the PCB in order to protect the GPU from outside ESD risk. For unused I2C signals, pull both the I2C_SCL and I2C_SDA lines to 1.8V or 3.3V using a 2.2 kΩ resistor. Although unused I2C lines can be soft-grounded (that is, grounded using a resistor), NVIDIA's diagnostic program expects them to be pulled up and will flag an error. So it is strongly recommended that unused I2C lines be pulled up.

15.2.1 Unconnected Signals
Unused GPIOs may be left floating (NC) on the board design.

Unused delete STEREO

STRAP2	STRAP1	STRAP0	RAMCFG[4:0]
L	L	L	00000
L	L	H	00001
L	H	L	00010
L	H	H	00011
H	H	L	00110
H	H	H	00111
L	L	M	01000

RAMCFG[4:0]	DENSITY	WIDTH	VENDOR	DIE
00000	8Gb	256-bit	Samsung	C
00001	8Gb	256-bit	Micron	A
00010	8Gb	256-bit	Hynix	M
00011	8Gb	256-bit	Samsung	C
00100	8Gb	256-bit	Micron	A
00101	8Gb	256-bit	Hynix	M
00110	16Gb	256-bit	Samsung	M
00111				

ROM_SO	ROM_SI	ROM_SCLK	DUMMY[2:0]	FS_OVERT	1.ENABLE 0.DISABLE	DEFAULT
L	L	L	XXX1		FS_OVERT ENABLE	DEFAULT
L	L	M	XXX0		FS_OVERT DISABLE	

STRAP5	STRAP4	STRAP3	SMB_ALT_ADDR	DEVID_SEL	PCI_E_CFG	VGA_DEVICE
M	H	H	1	1	1	1
M	H	L	1	1	1	0
M	L	H	1	1	0	1
M	L	L	1	1	0	0
L	H	M	1	0	1	1
L	M	H	1	0	1	0
L	M	L	1	0	0	1
L	L	M	1	0	0	0
H	H	H	0	1	1	1
H	H	L	0	1	1	0
H	L	H	0	1	0	1
H	L	L	0	1	0	0
L	H	H	0	0	1	0
L	L	H	0	0	0	1 DEFAULT
L	L	L	0	0	0	0

H=High :Tied to 1.8V
M=Middle:Tied to 0.9V
L=Low :Tied to 0V

1:SMB_ALT_ADDR ENABLE
0:SMB_ALT_ADDR DISABLE
1:DEVID_SEL REBRAND
0:DEVID_SEL ORIGINAL

1:PCI_E_CFG LOW POWER
0:PCI_E_CFG HIGH POWER
1:VGA_DEVICE ENABLE
0:VGA_DEVICE DISABLE

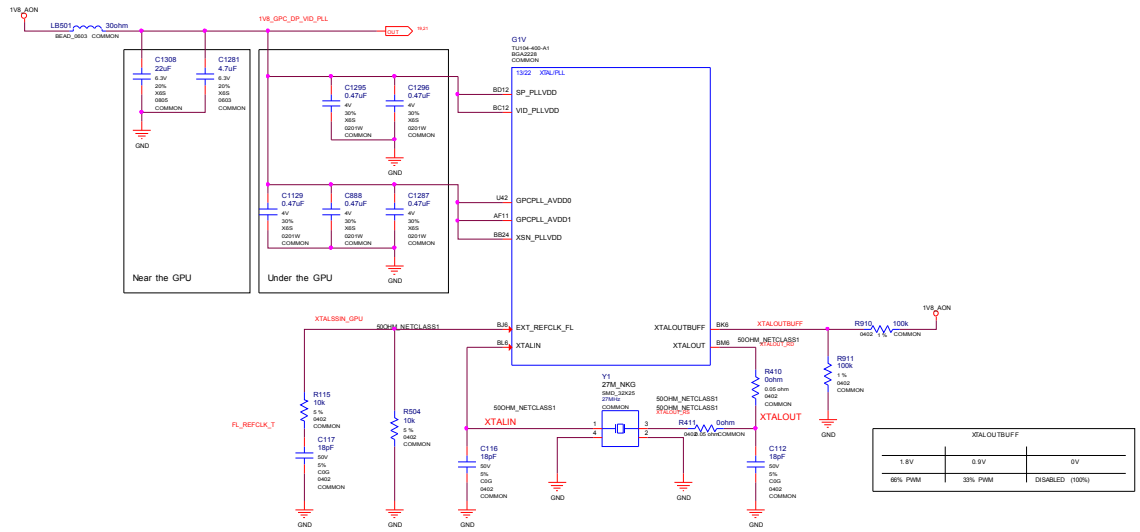
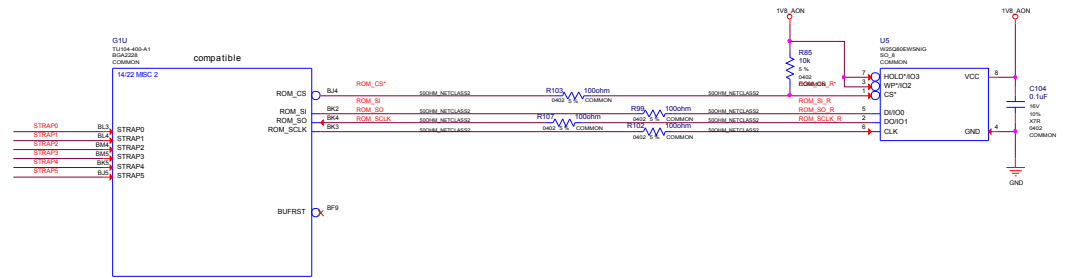
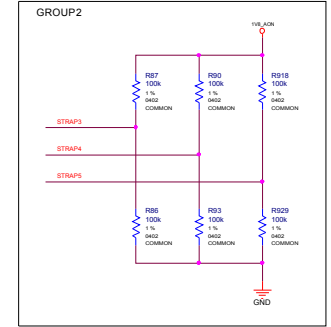
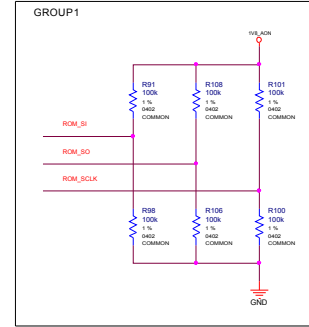
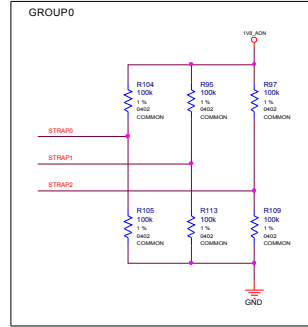

XTALOUTBUFF		
1.8V	0.9V	0V
86% PWM	33% PWM	DISABLED (100%)

1v8 Switcher

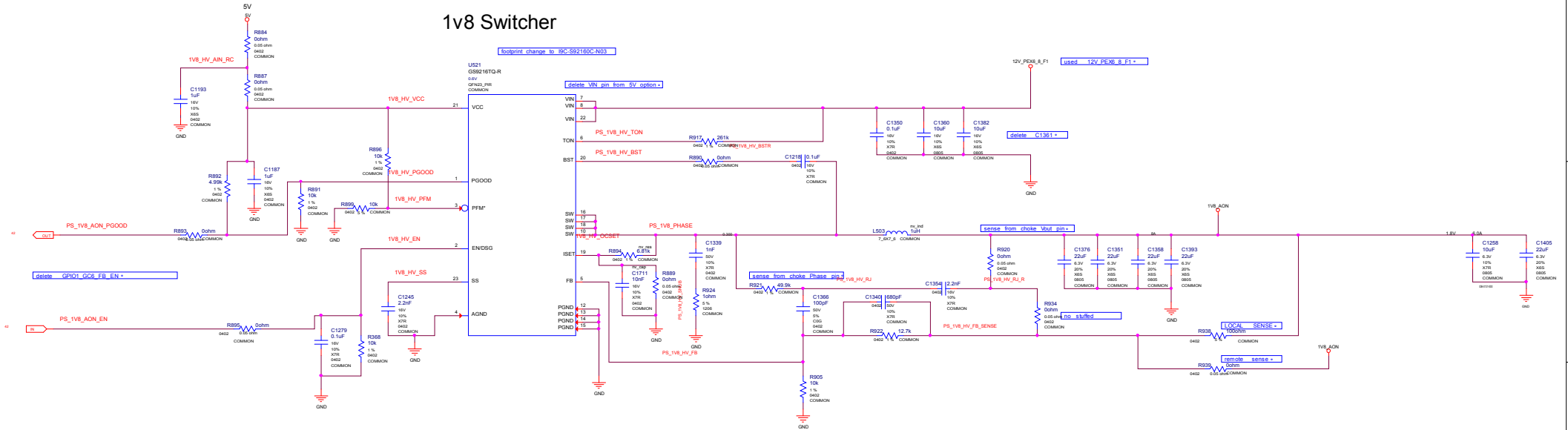

- 1 L503 PNL04-01074K0-L65 / footprint : CHK_S2_7_3X6_61
- 2 delete colayout PWM output choke
- 3 delete 1V8_MA N and merged to 1V8_AON

- 1 L510 P N L04-0507010-L65 / footprint : CHK_S2_5_4X5_23
- 2 d d e colayout P WM output choke
- 3 unused RTD3 d d e Buck Boost regulat or

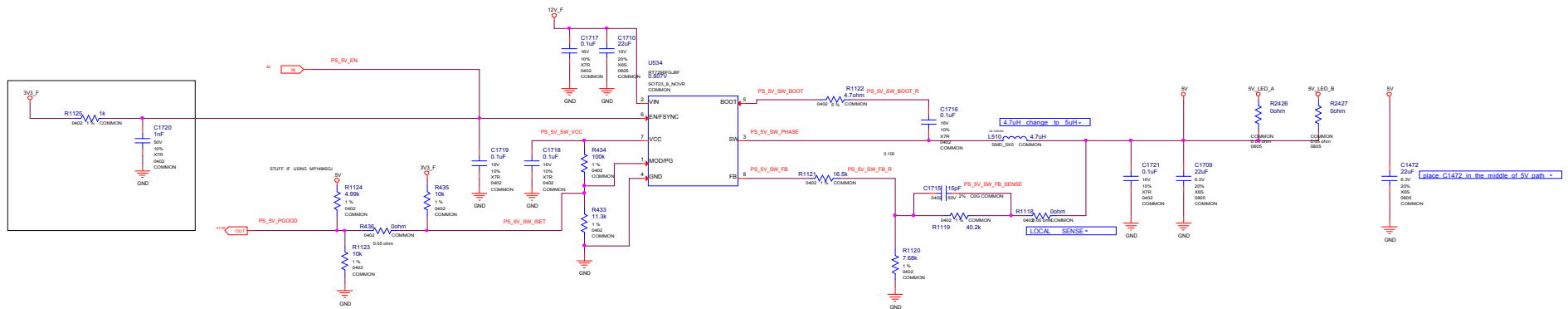

				MICRO-STAR INT'L CO.,LTD		
				MS-V375		
Size	Document	Description	Rev			
Custom	PS: 5V		4.0			
Date: Friday, November 09, 2018				Sheet	27	of 54

PEX Switcher

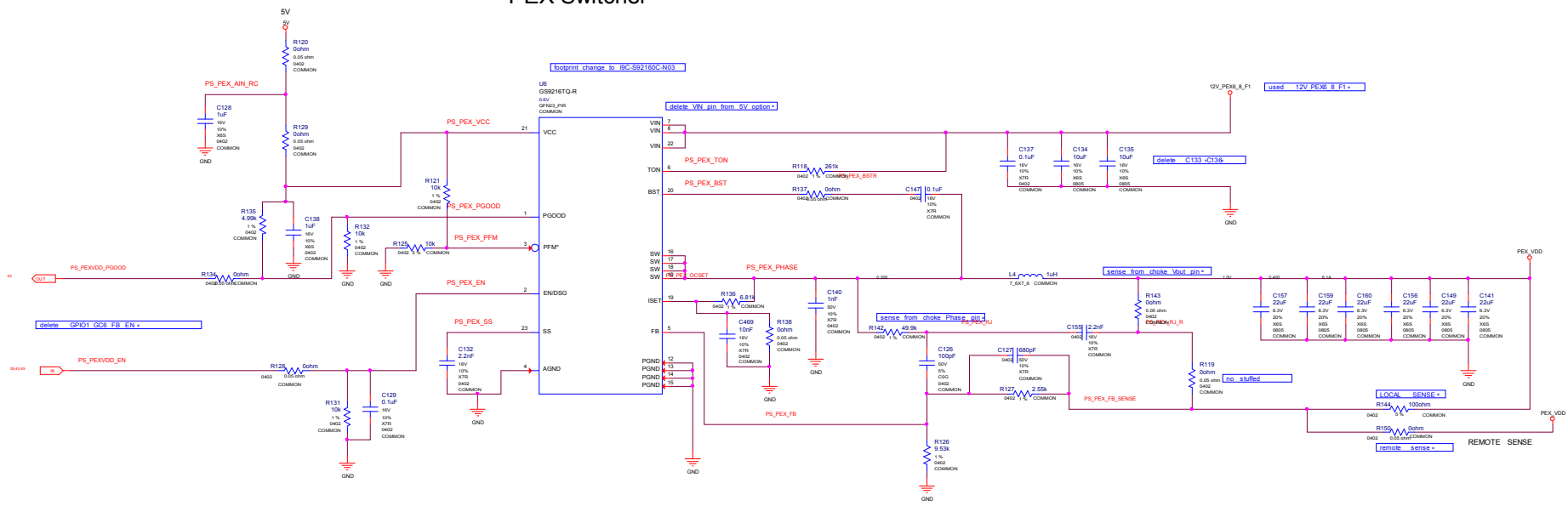

1 L4 PN L04-0107410-L65 / footprint : CHK_S2_7_3X6_61
 2 delete colayout PWM output choke

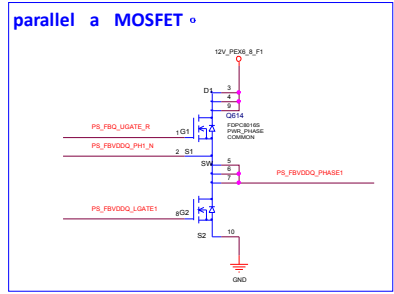
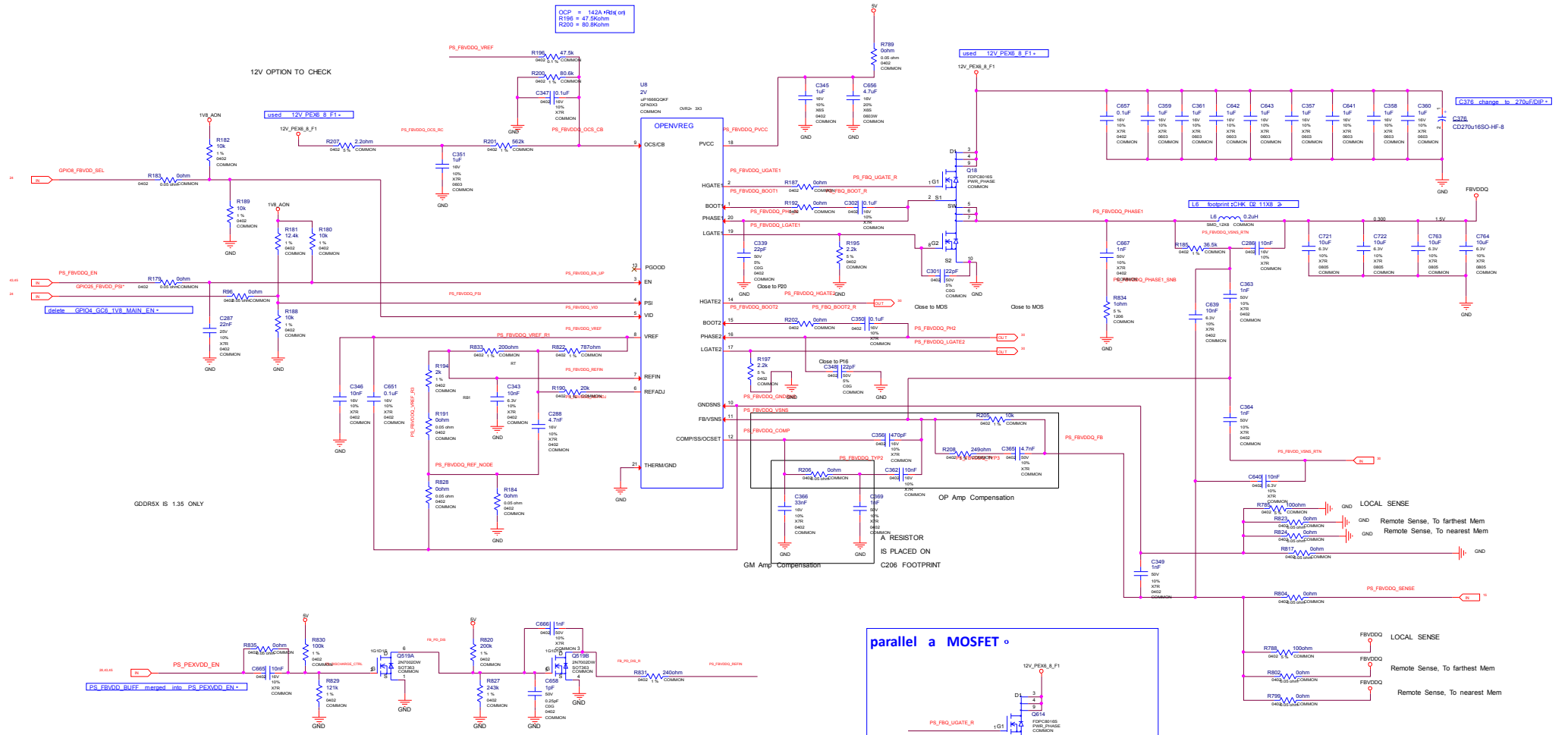

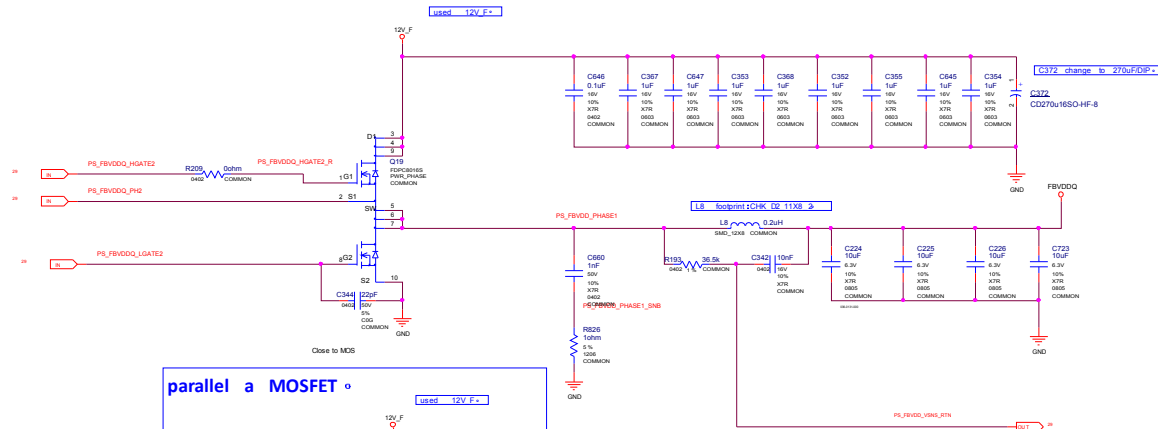

delete RTD3 backdrive ◦

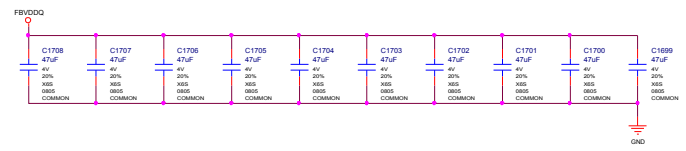
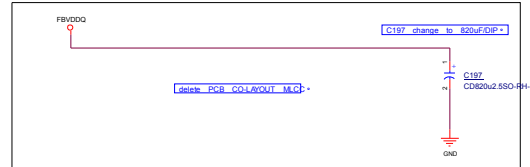
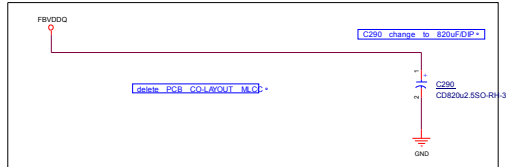
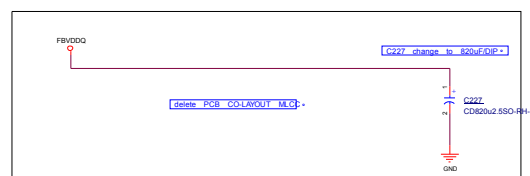
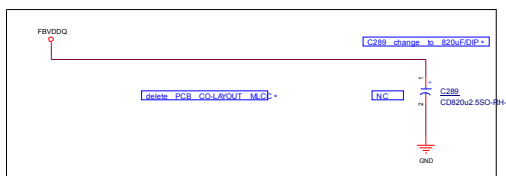
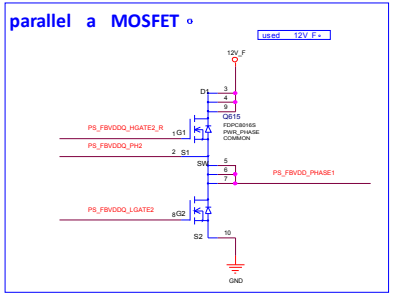

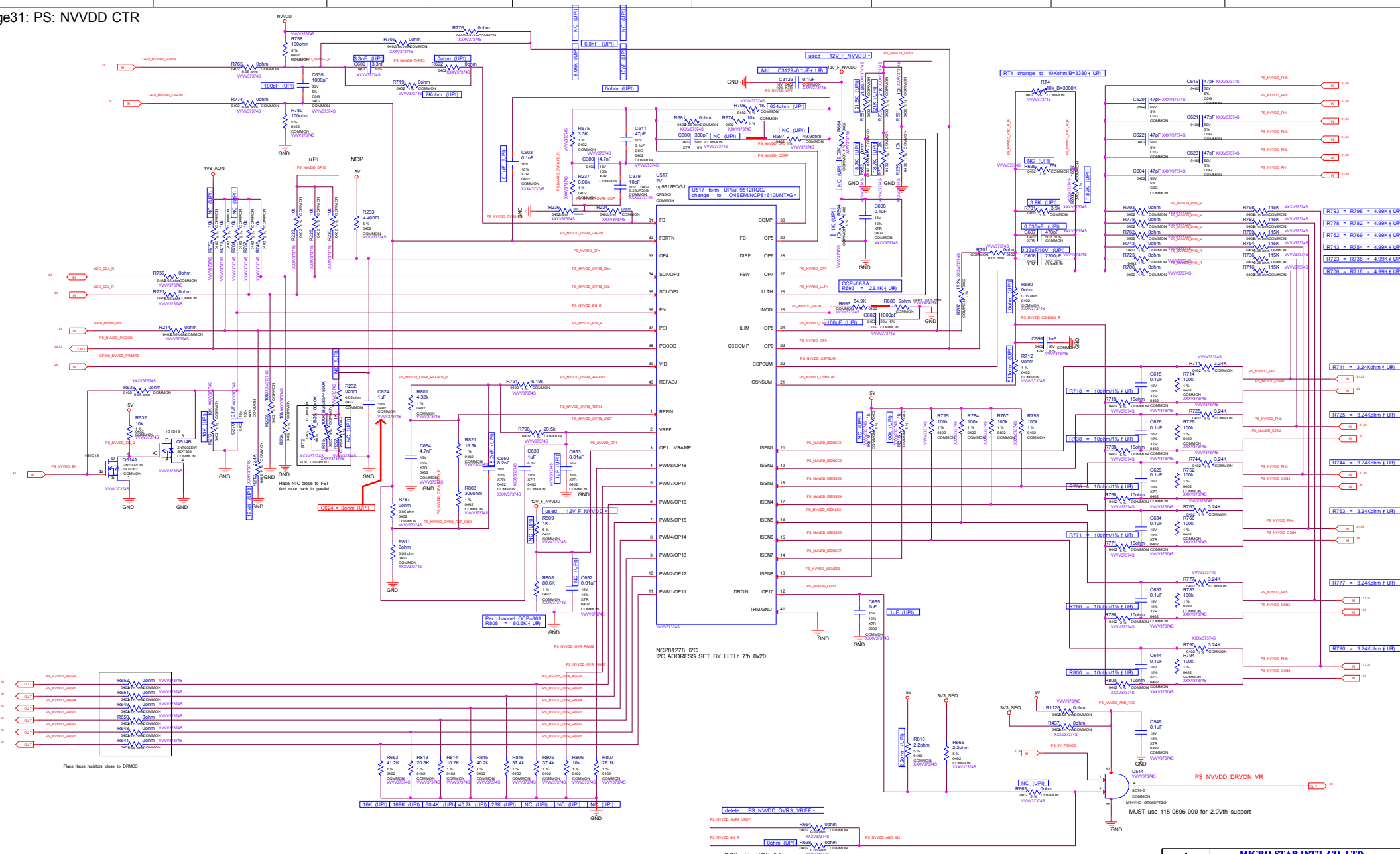

- Place these resistors close to DRMS
- R852 10k
- R853 41.2k
- R854 10k
- R855 10k
- R856 10k
- R857 10k
- R858 10k
- R859 10k
- R860 10k
- R861 10k
- R862 10k
- R863 10k
- R864 10k

delete all unused

	MICRO-STAR INT'L CO.,LTD		
	MS-V375		
	Size Custom	Document Description PS: NVVDD CTR OVR3i	Rev 4.0
Date: Friday, November 09, 2018			
Sheet 32 of 54			

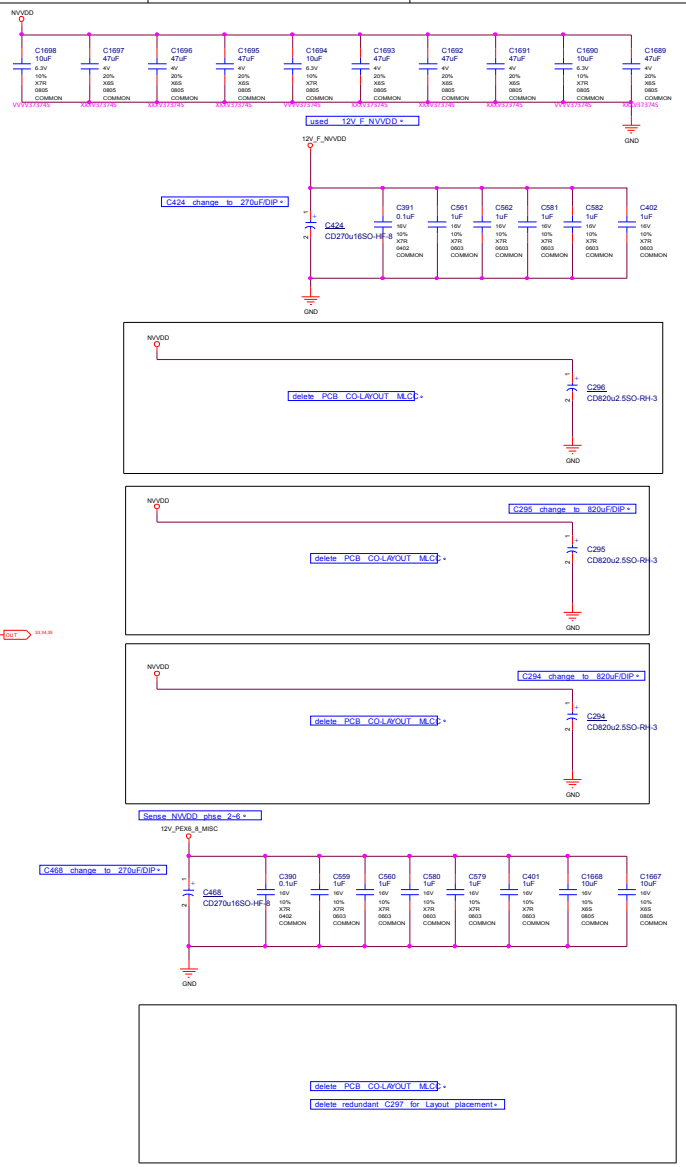
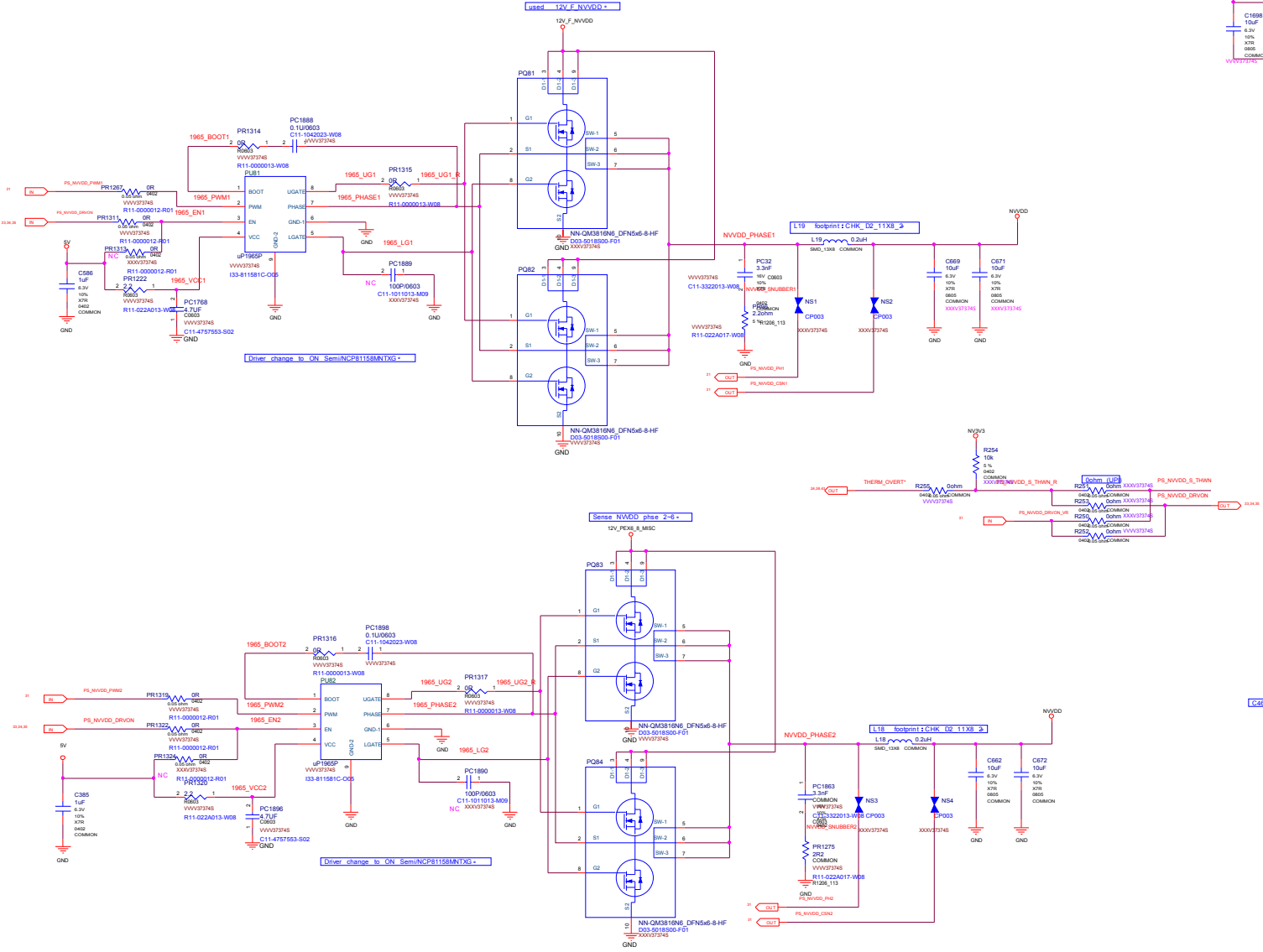

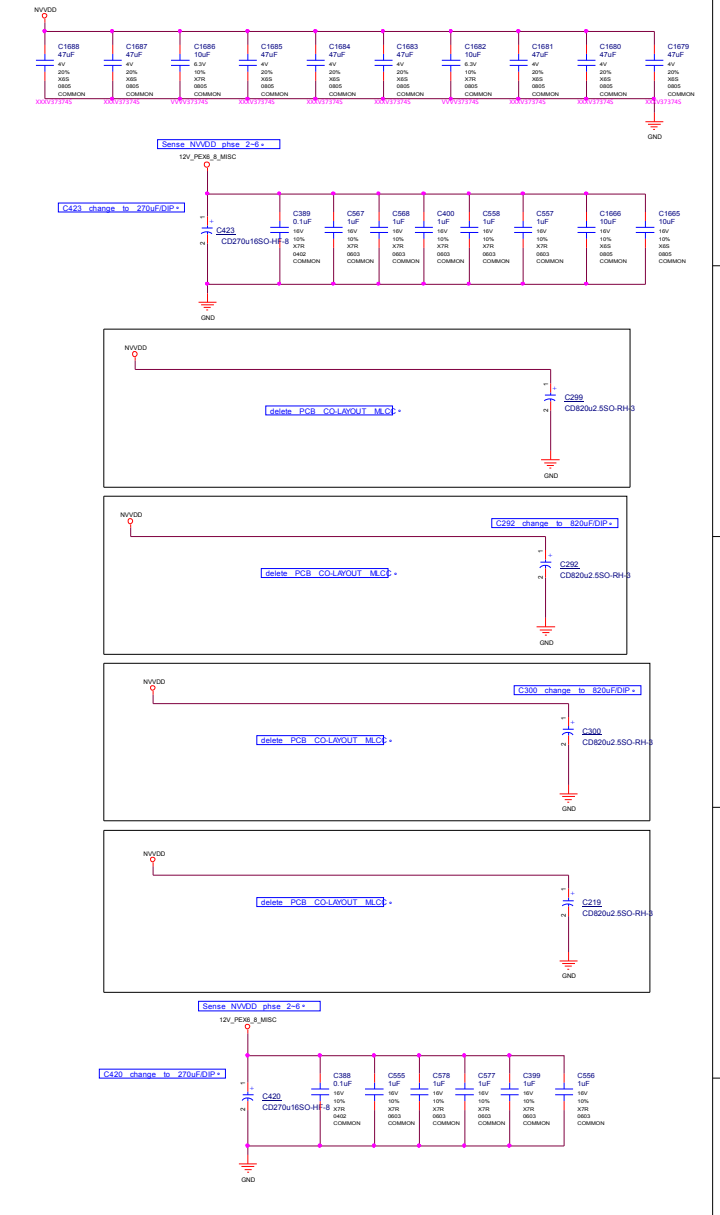
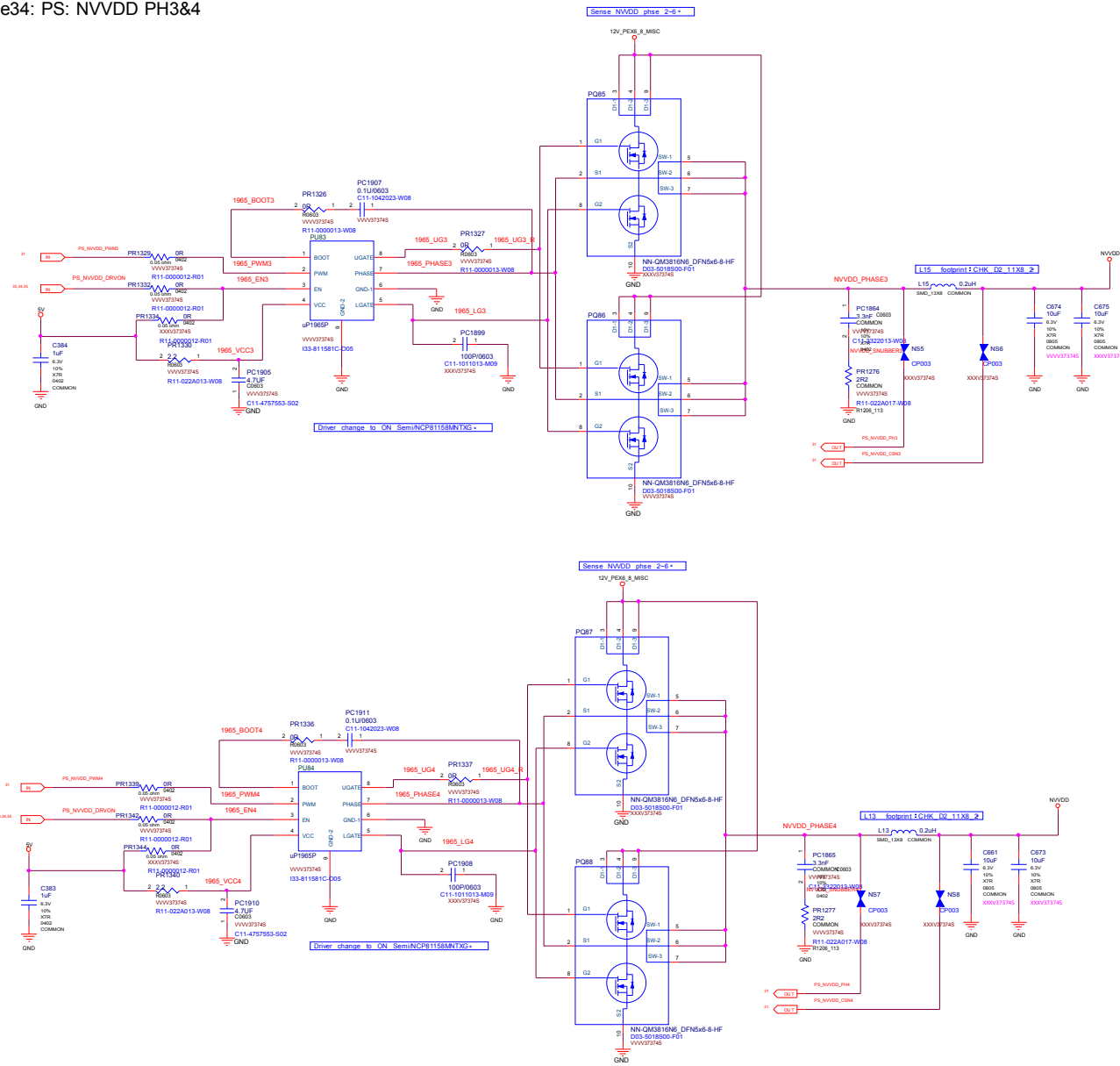

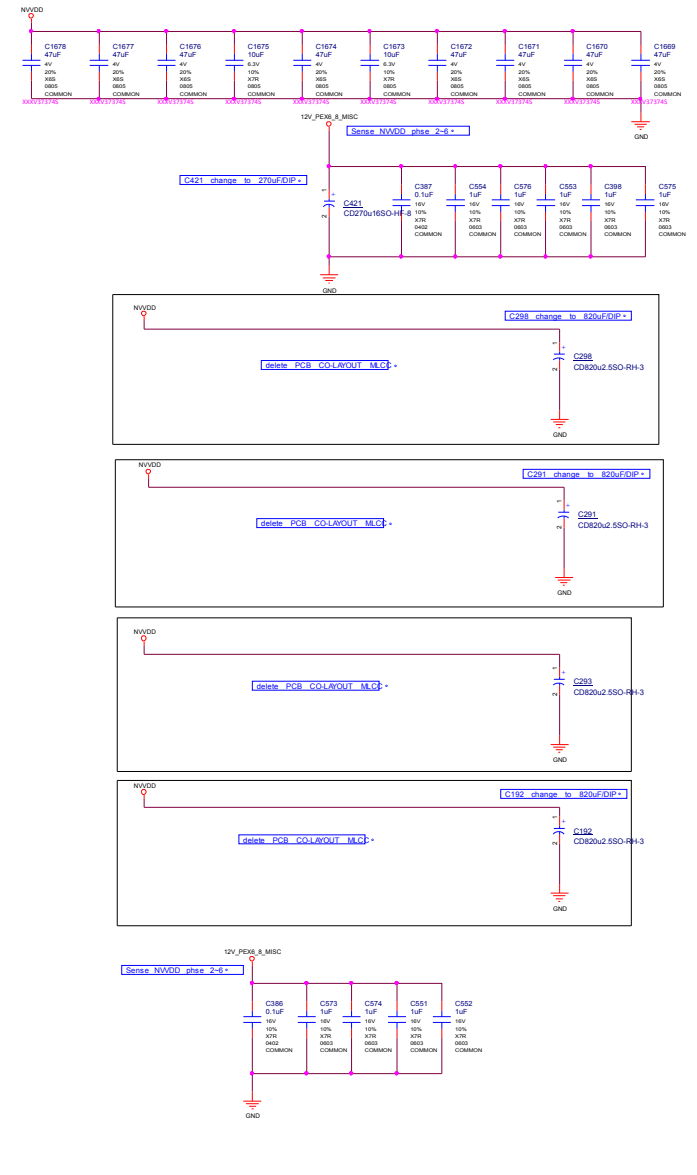
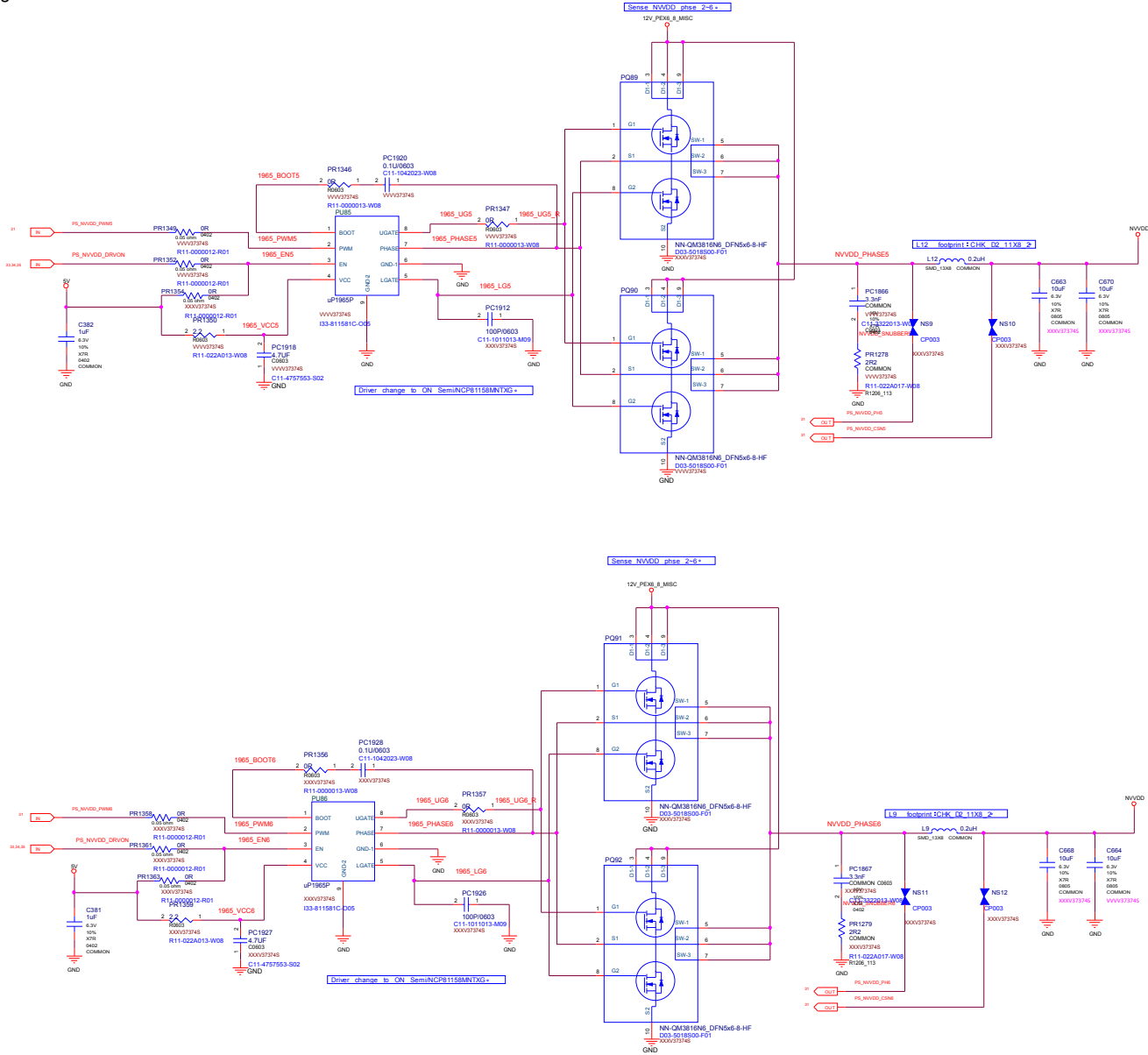

removed U511 for fixed NVVDD 12V input:
1 merged 3V3_AON to 3V3_F
2 unused and delete 3V3_AUX
3 unused and delete 3V3_AUX_CON
4 NVVDD_DYN_VIN merged to 12V_PEX6_8_F1

delete GPDI2_INOUT_DYN_BAL1

delete INPUT_PEX6_D11_STEER

- 1 changed EXT 12V 8pin PN and footprint
- 2 add EXT 12V 8pin Fuse
- 3 delete unused parts
- 4 RSENSE 3 change to sense NVVDD PEX 12V
- 5 RSENSE 4 change to sense NVVDD EXT 12V
- 6 change RSENSE parts and footprint

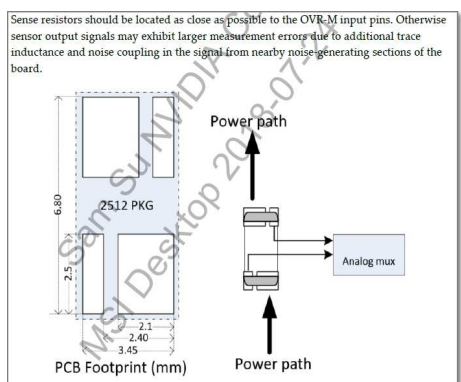
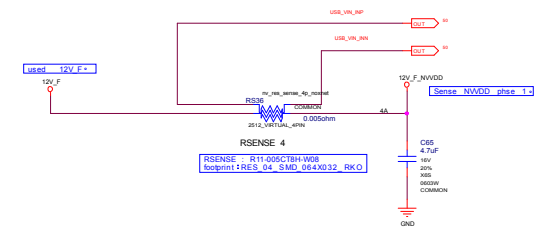
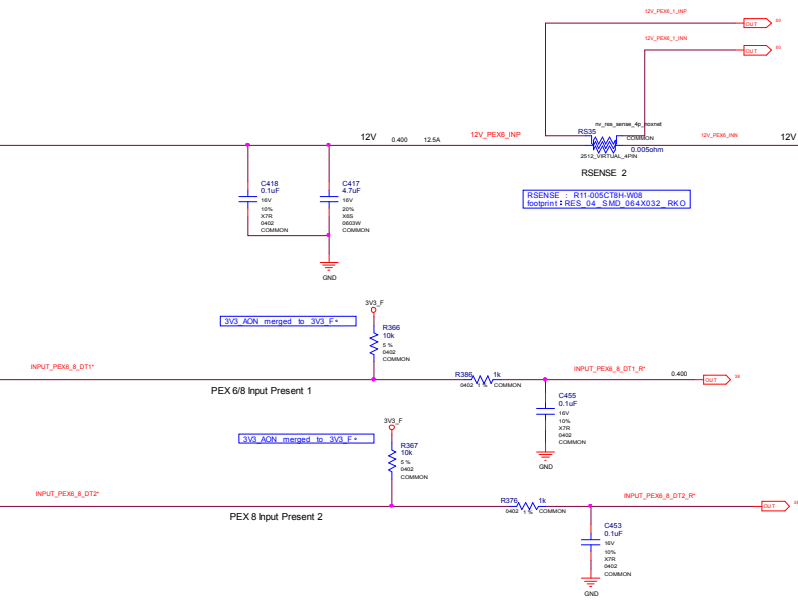
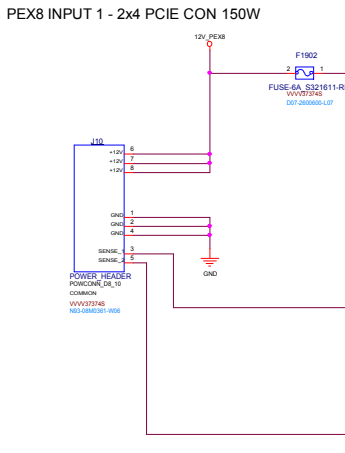
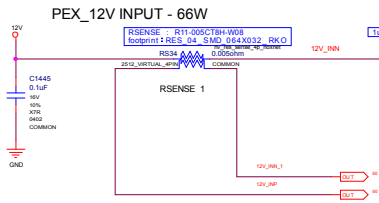
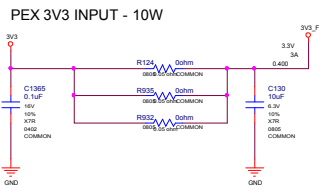
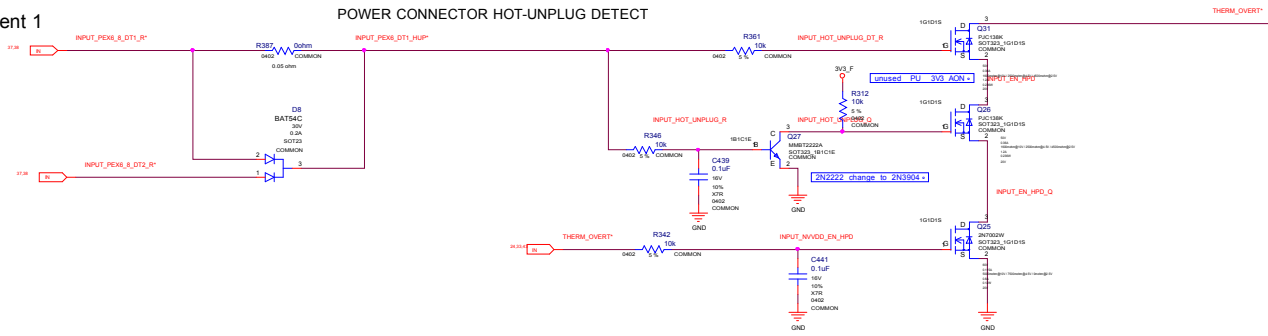

Figure 5.10 Connection for 2-Pin Sense Resistor (2512 Package)
 If customer prefers using a 2-pin sense resistor instead, we recommend implementing a 4-pin footprint with two large PADS for the high current path and two small PADS for sensing line, to emulate the functionality of a 4-pin resistor.

Note: Two-pin sense resistor can be used, but the sensing signal MUST connect to resistor pad directly. Connect the sensing signal to nearby power plane may cause large measurement error.

PEX Input Present 1



12V CURRENT STEERING (UNDER POWER BOOT):

GUIDES CURRENT FROM PEX EDGE TO PEX 6 PIN INPUT AREA

copied 12V CURRENT STEERING from V373-2.0 and BOM stuff ed

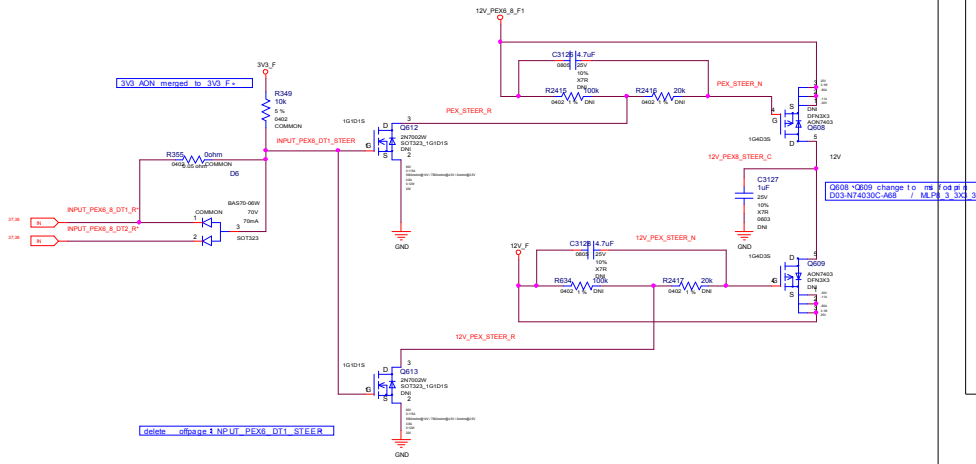

PEX Input - Power Level/PSI* Control

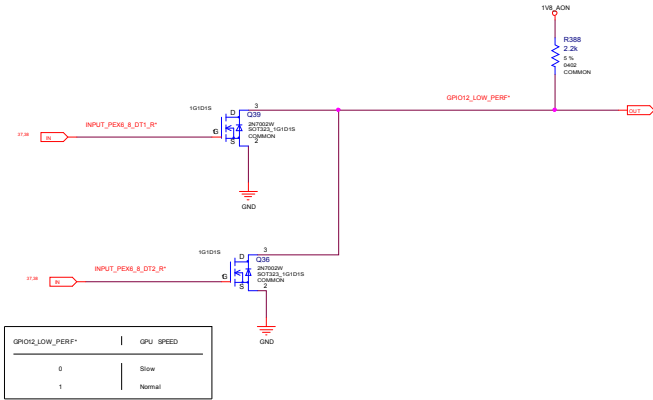

delete regulator for USBC_VBUS ◦

Unused USB_I2C* leaving Pull high resistor to 1.8V ◦

delete PPC ◦

Unused USB_I2C* leaving Pull high resistor to 1.8V ◦

Unused IFPB_I2C* leaving Pull high resistor to 1.8V ◦

delete GPC04_IFPB_HFD ◦

delete PEX_EST_BUF* ◦

delete GPC01_GCS_FB_EN* ◦

	MICRO-STAR INT'L CO.,LTD		
	MS-V375		
	Size Custom	Document Description PPC	Rev 4.0
Date: Friday, November 09, 2018			
Sheet 40 of 54			

unused and delete all °

delete GP01_GCK_FB_EN+
delete GP02_DLE_IN_SW1

delete offpage RFD SWITCH

unused and delete C004

	MICRO-STAR INT'L CO.,LTD		
	MS-V375		
	Size Custom	Document Description 12V & 3V3_A SWITCHER	Rev 4.0
Date: Friday, November 09, 2018		Sheet 41 of 54	

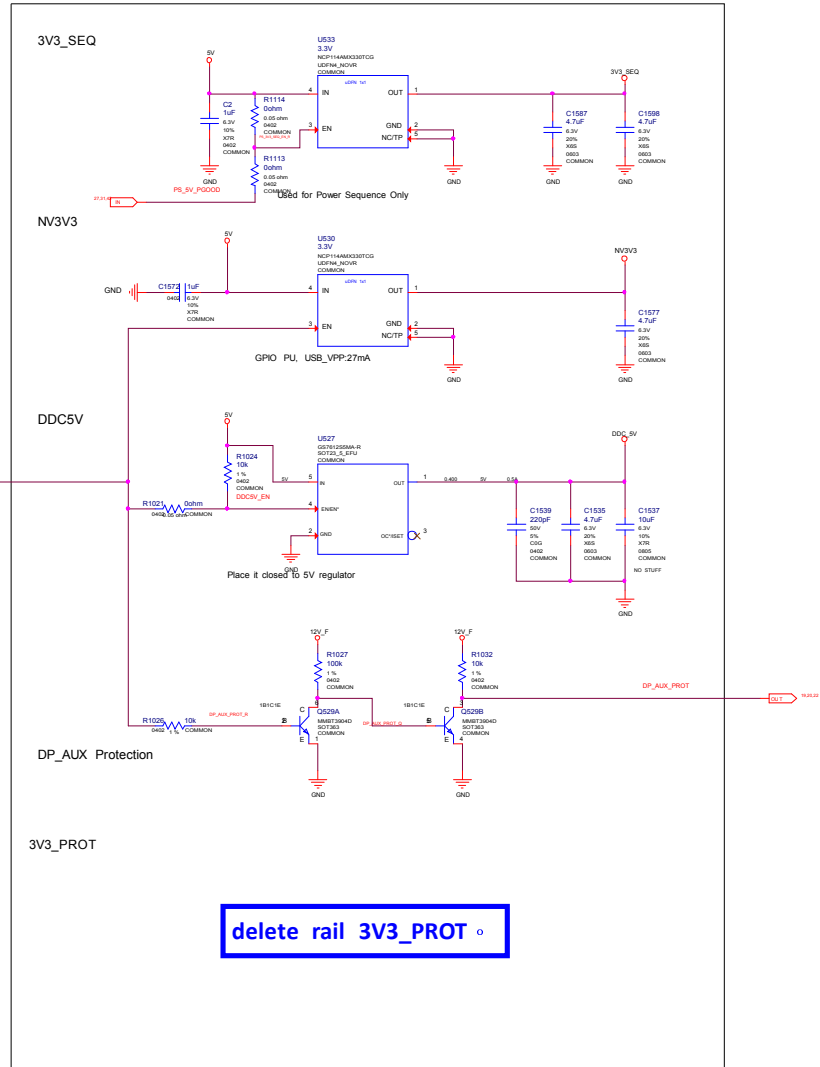
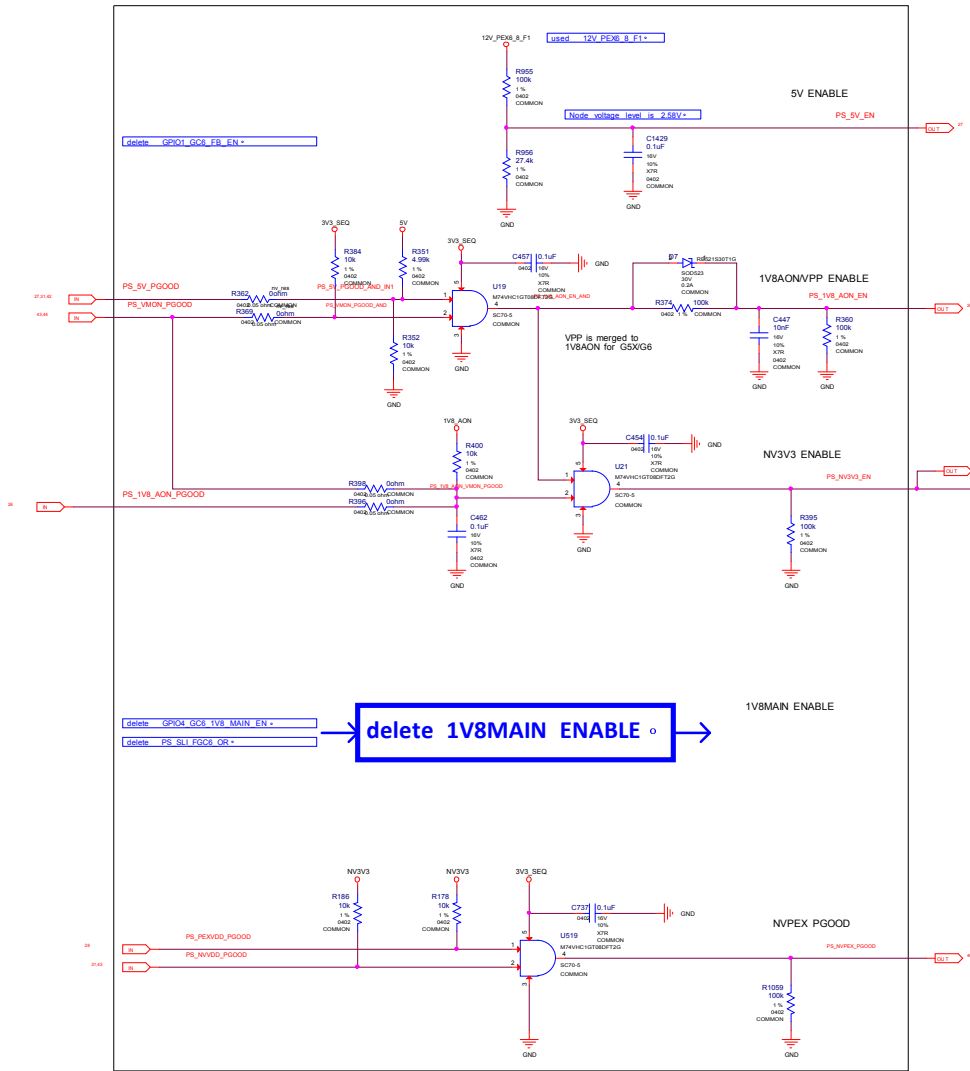

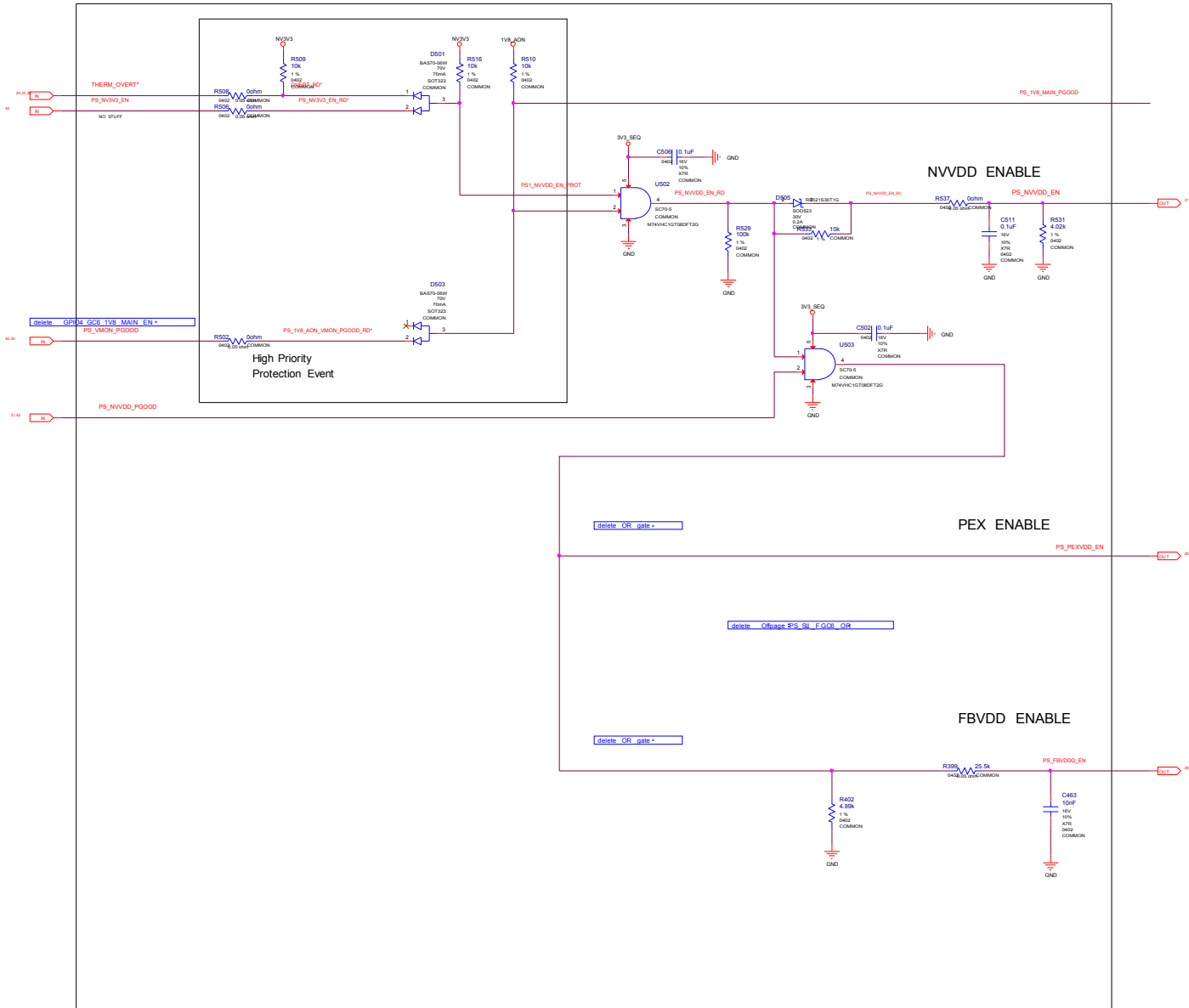

delete unused parts ◦

Voltage Monitor

Route the trace to PCIe Golden Finger

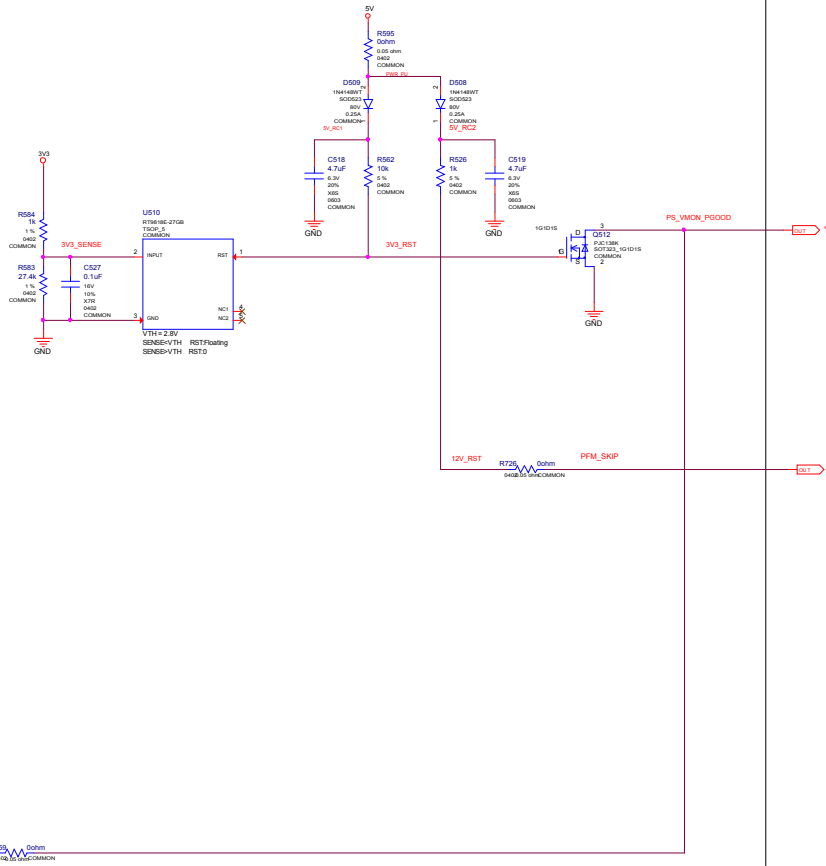

delete GPC1_G0C6_FB_EN+

delete PS_3TD_SWITCH+

PFM_PF_BSK

BOM Configuration

OPTIONS	PEX3V3_SENSE	PEX12V_SENSE	OTHER_12V_SENSE
Use Pre-Filter	Pre-Filter	Pre-Filter	Pre-Filter
Use INA3221	Voltage_Monitor	INA3221	INA3221
NO INA3221	Voltage_Monitor	Voltage_Monitor	N/A
NO Pre-Filter			

Signal	Direction	Function
3V3	INPUT	Sense the 3V3 Voltage from PCIe golden finger
12V	INPUT	Sense the 12V Voltage from PCIe golden finger
PS_VMON_PGOOD	OPEN-DRAIN	Floating(H) once both 3V3 and 12V reach Vth
GC6_FB_EN	INPUT	Indicator for RTD3/GC6 residence.Use to Mask the VMON_PGOOD
PS_PF_SKIP	INPUT	From INA3221(VPU) or Pre-filter(SKIP)
PS_PF_BSK	INPUT	From INA3221(PV) or Pre-filter(BS_OK)

MICRO-STAR INT'L CO.,LTD
MS-V375

Size: Custom	Document Description: SEQUENCE:Voltage Monitor	Rev: 4.0
Date: Friday, November 09, 2018	Sheet: 44	of: 54

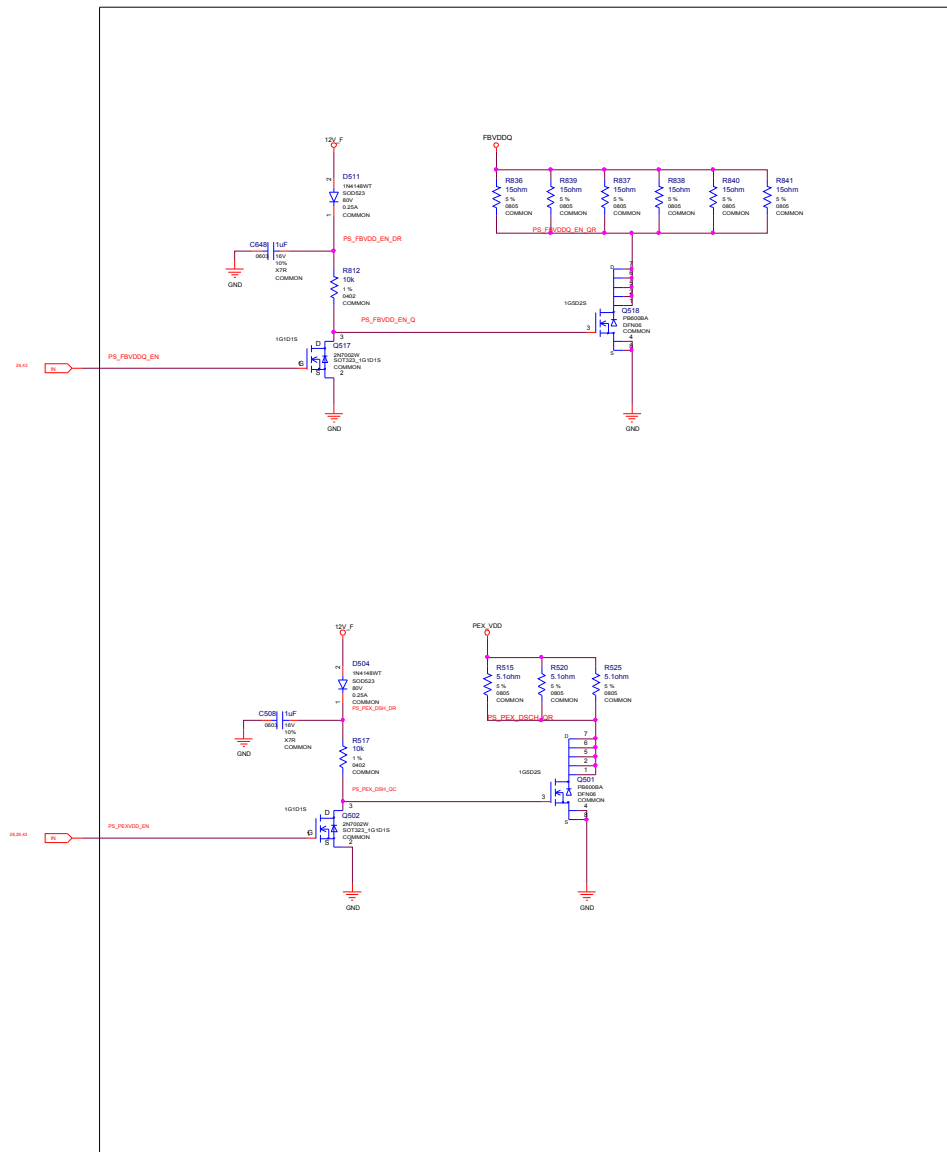

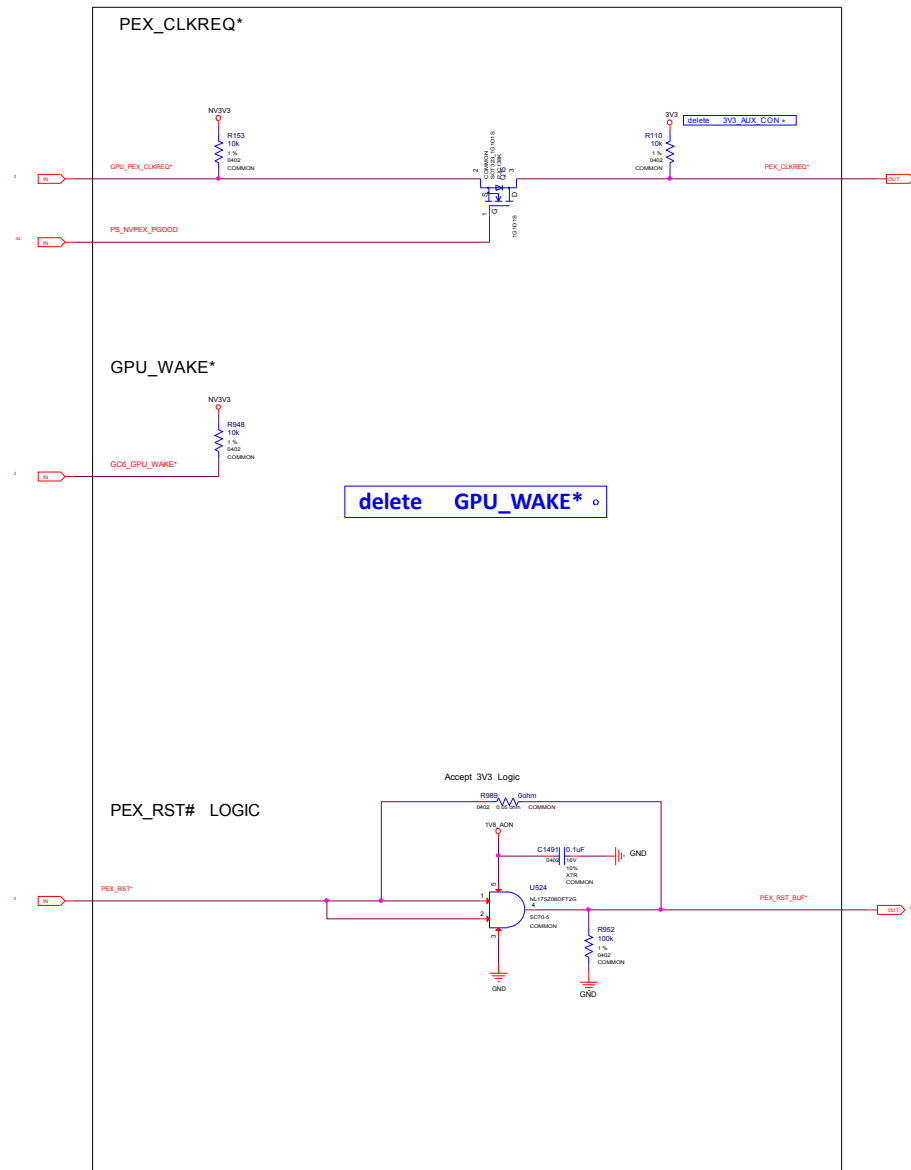

delete all unused

	MICRO-STAR INT'L CO.,LTD		
	MS-V375		
	Size Custom	Document Description LOGO LED	Rev 4.0
Date: Friday, November 09, 2018		Sheet 47 of 54	

delete all unused

copied V373-2.0 housing PN and footprint ◦

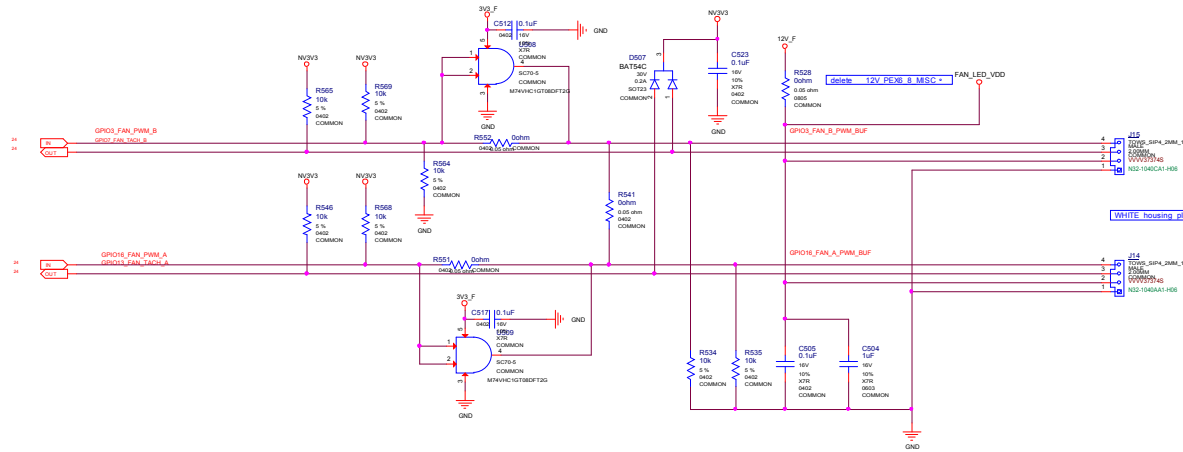

		MICRO-STAR INT'L CO.,LTD	
MS-V375			
Size	Document	Description	Rev
Custom	DUAL FAN		4.0
Date: Fri, Nov 09, 2018		Sheet: 49	of 54

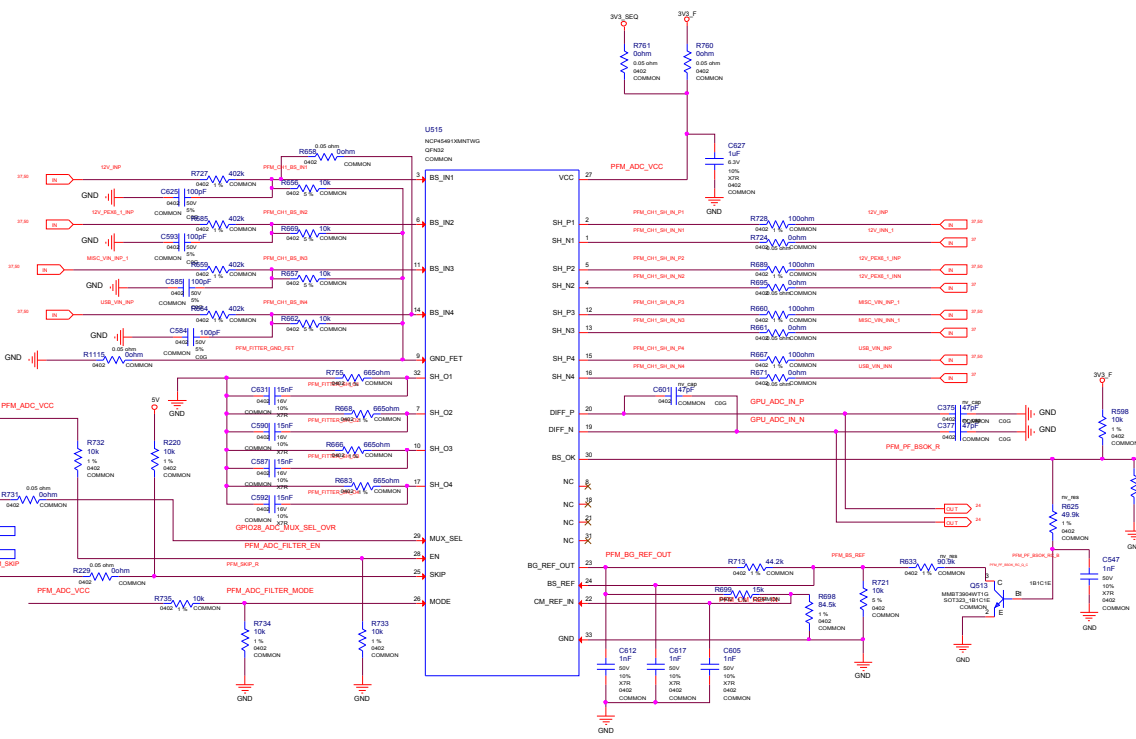

MODE PIN STATUS	MULTIPLEXER OPERATION
LOW	DEVICE A
TRI-STATE(FLOATING)	STAND-ALONE
HIGH	DEVICE B

ENABLE PIN STATUS	MULTIPLEXER OPERATION
LOW	FULLY FUNCTIONAL
TRI-STATE(FLOATING)	LIMITED FUNCTION
HIGH	STANDBY

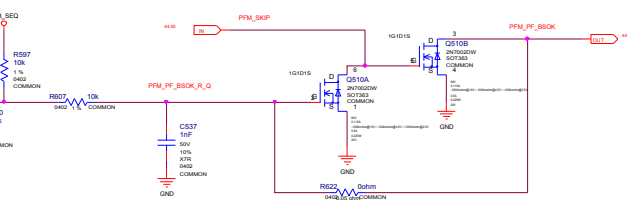

MICRO-STAR INT'L CO.,LTD

MS-V375

Size: Custom Document Description: PWR SENSE Rev: 4.0
 Date: Friday, November 09, 2018 Sheet: 50 of 54

Brackets:

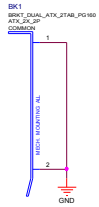

MOUNTING HOLES FOR HS:

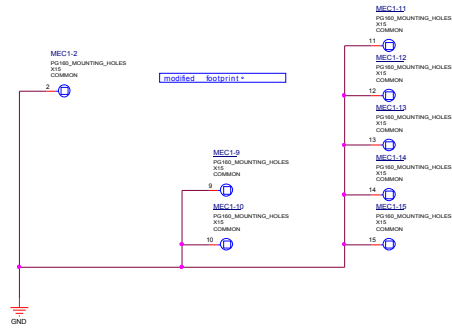

Mechanical Holes Symbol

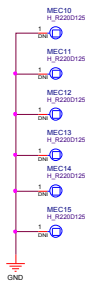

Bracket Screw

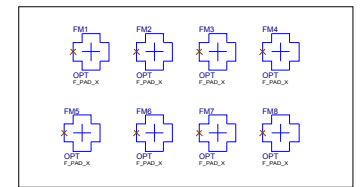
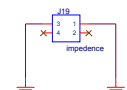
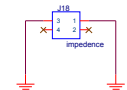

improved FBVDDQ PSU parts don't require a PTC

	MICRO-STAR INT'L CO.,LTD		
	MS-V375		
	Size Custom	Document Description PTC	Rev 4.0
Date: Fri, Nov 09 2018		Sheet 52 of 54	

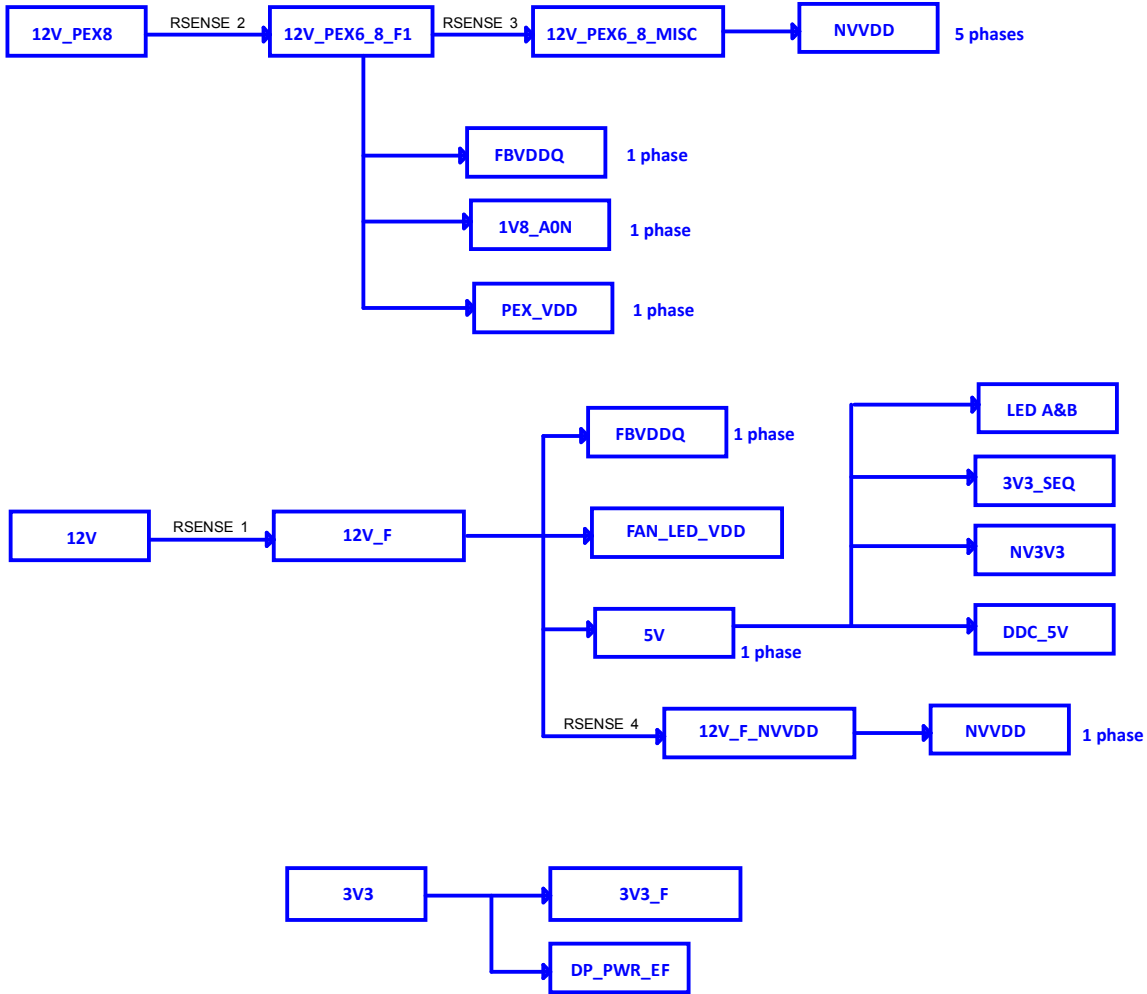

Power on Sequence

