

PG161-A00

TU106 6GB GDDR6, 192b, X16 DVI-D/DP + DP + HDMI

TABLE OF CONTENTS

Page Description

1	Table of Contents
2	Block Diagram
3	PCI Express
4	PCIE RC TERM
5	MEMORY: GPU FB_AB
6	MEMORY: FBA[31:0]
7	MEMORY: FBA[63:32]
8	MEMORY: FBB[31:0]
9	MEMORY: FBB[63:32]
10	MEMORY: GPU FB_CD
11	MEMORY: FBC[31:0]
12	MEMORY: FBC[63:32]
13	MEMORY: FBD[31:0]
14	MEMORY: FBD[63:32]
15	GPU PWR & GND
16	GPU Decoupling
17	GPU Decoupling2
18	IO: IFPAB DVI-D-DL
19	IO: IFPA DP
20	IO: IFPB DP
21	IO: IFPE & IFPF USBC NC
22	IO: IFPC HDMI
23	IO: IFPD DP
24	IO: NVHS Interface and Frame Lock
25	MISC1: Thermal, JTAG, GPIO,STEREO

Page Description

26	MISC2: ROM, XTAL,STRAPS
27	PS: 1V8_AON
28	PS: 5V
29	PS: PEXVDD
30	PS: FBVDDQ
31	PS: FBVDDQ PH2
32	PS: NVVDD Controller
33	PS: NVVDD Controller OVR3i
34	PS: NVVDD Phase 6,4
35	PS: NVVDD Phase 3,5
36	PS: NVVDD Phase 2,1
37	PS: Input Power Balancing Switcher
38	PS: Input, Filtering, and Monitoring
39	PS: STEERING, UPB & HOT-UNPLUG
40	PS: Type-C BuckBoost
41	PD PPC
42	PS: 12V & 3V3_A SWITCHER
43	SEQ: 5V, 1V8, NV3V3 ENABLE
44	SEQ: NV, PEX, FB ENABLE
45	SEQ: VOLTAGE MONITOR
46	SEQ: DISCHARGE
47	SEQ: MISC
48	LOGO LED
49	LED DRIVER & BOOST
50	FAN

Page Description

51	PS: Pre-filter
52	MECH
53	PTC

	MICRO-STAR INT'L CO.,LTD		
	MS-V375		
	Size Custom	Document Description TABLE	Rev 2.0
Date: Monday, December 10, 2018		Sheet 1 of 53	

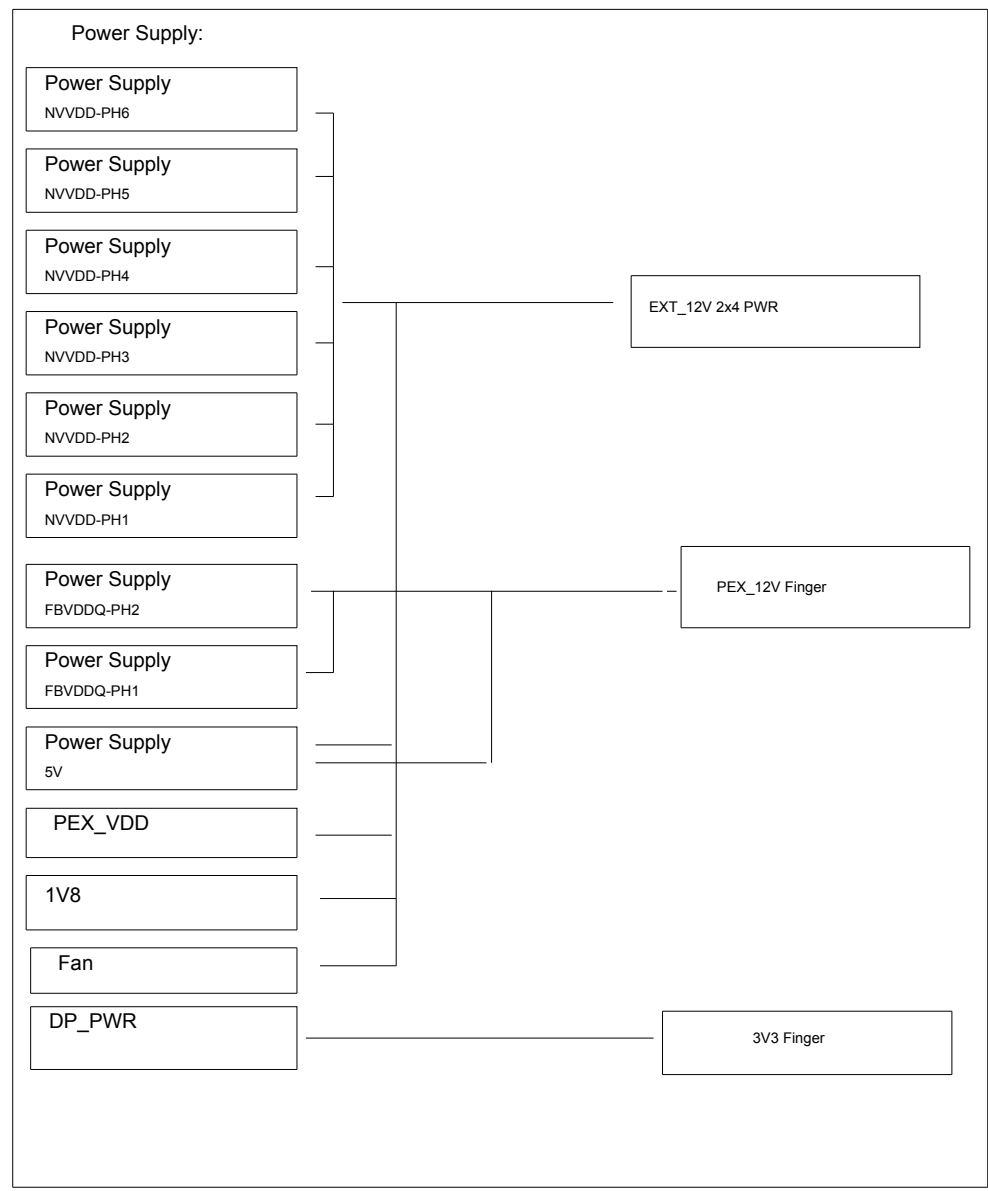
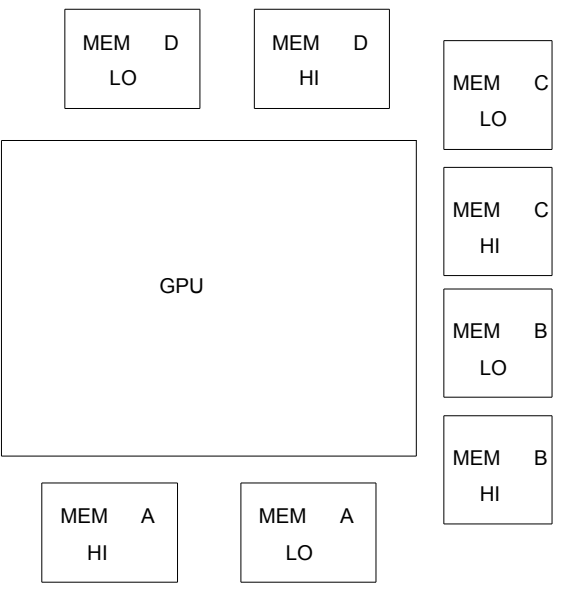
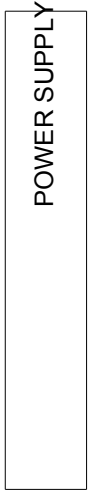
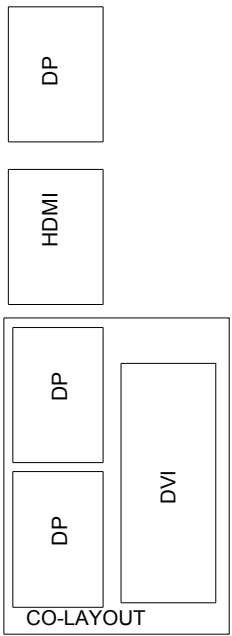

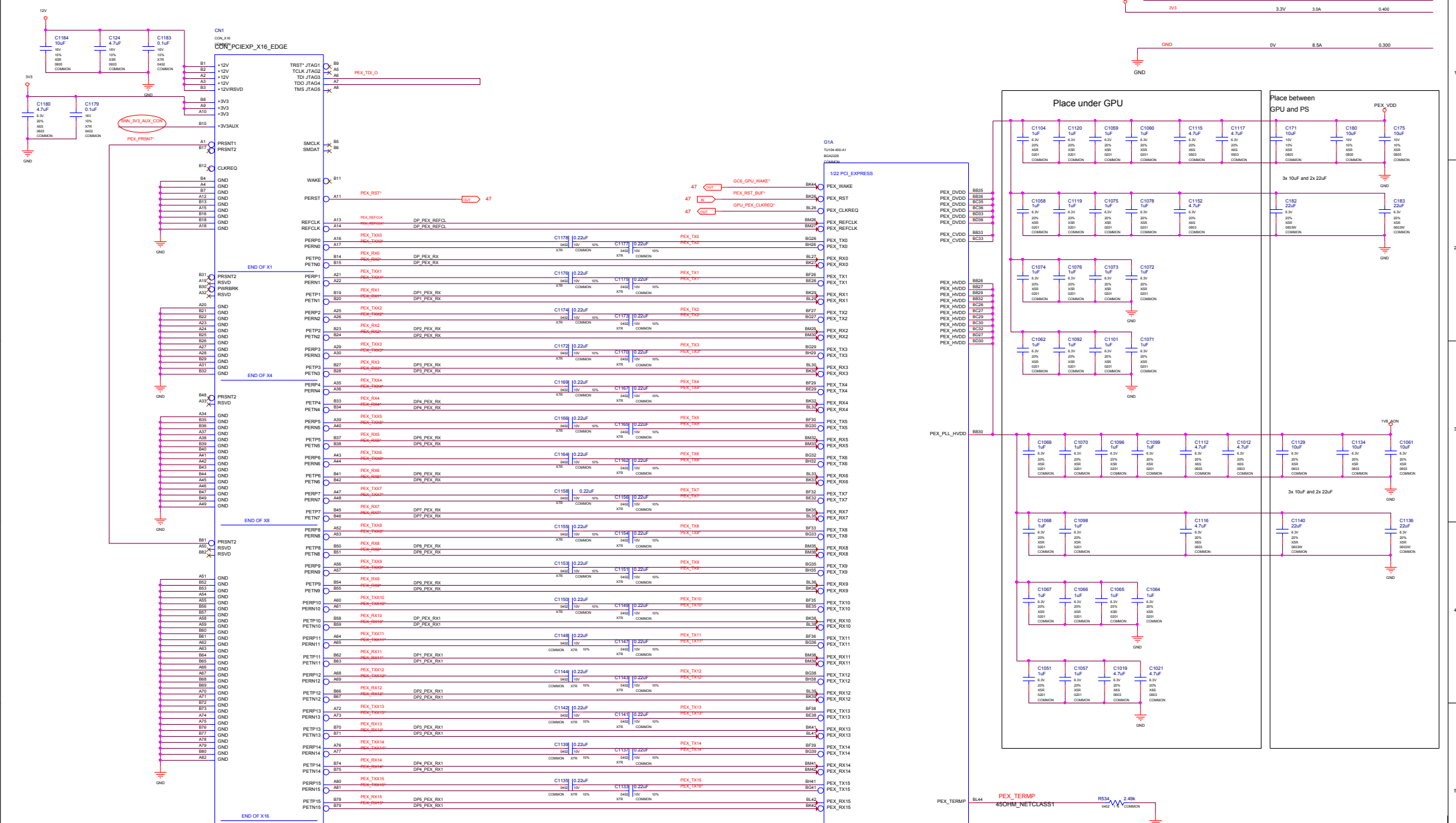

		MICRO-STAR INT'L CO.,LTD MS-V375		Rev Z.0
		Size: Custom Document Description: PCI Express Date: Monday, December 10, 2018 Sheet: 3 of 53		

NO PEX GEN4 SUPPORT DELETE RC TERMINATIONS

	MICRO-STAR INT'L CO.,LTD	
	MS-V375	
	Size Custom	Document Description PCIE RC TERM
Date: Monday, December 10, 2018		Sheet 4 of 53

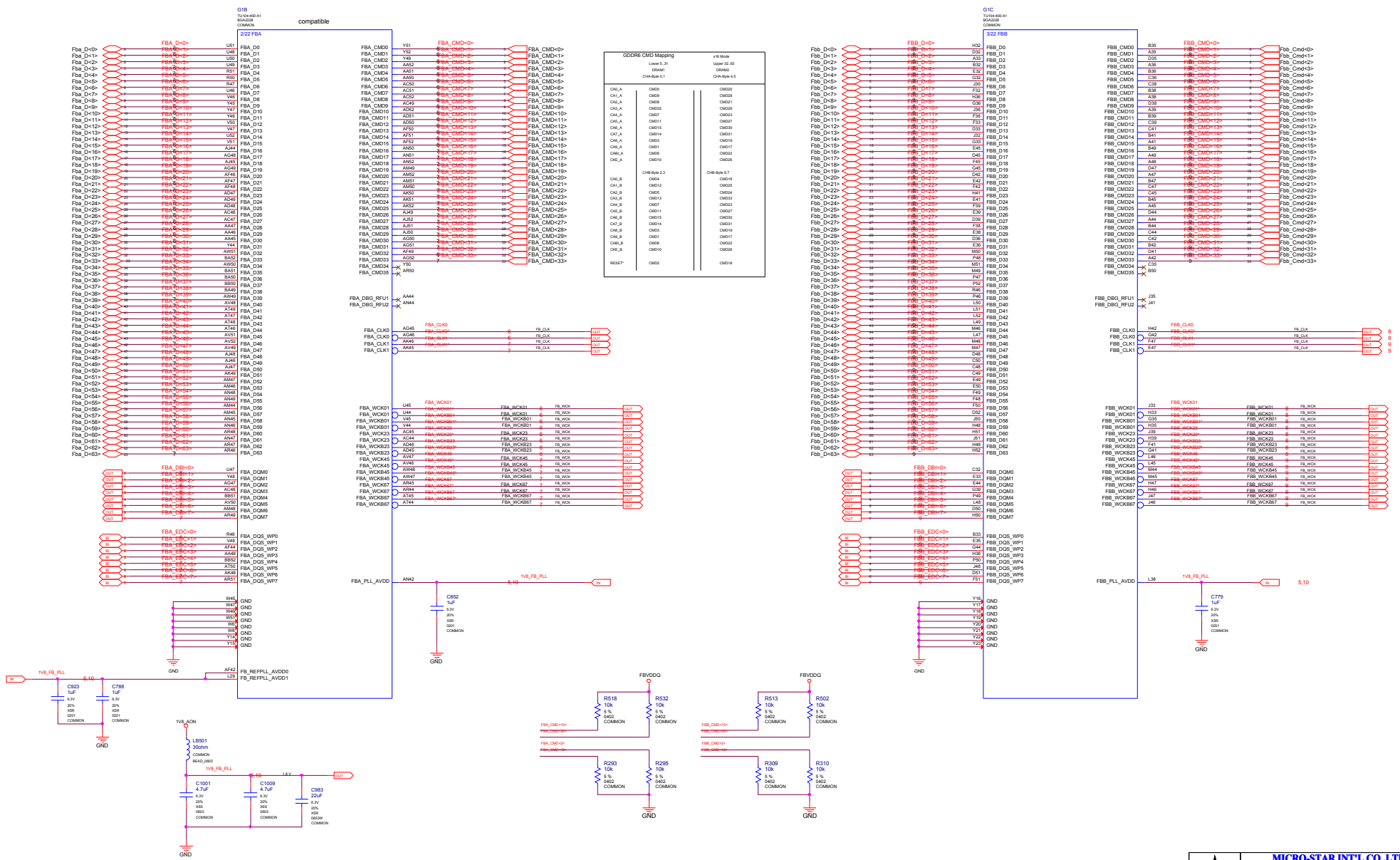

MICRO-STAR INT'L CO.,LTD
MS-V375

Size: Custom | Document Description: MEMORY: GPU Partition A/B | Rev: 2.0
 Date: Monday, December 10, 2018 10:11:11 | Sheet: 5 of 53

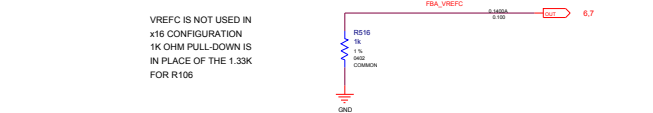
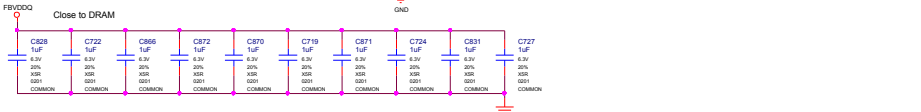
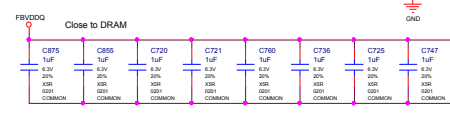
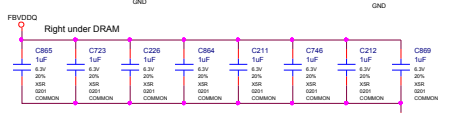
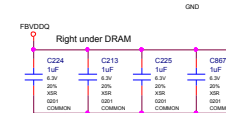
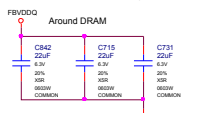
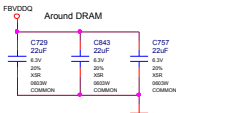
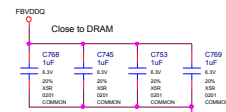
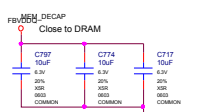
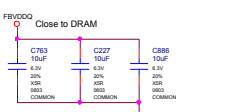
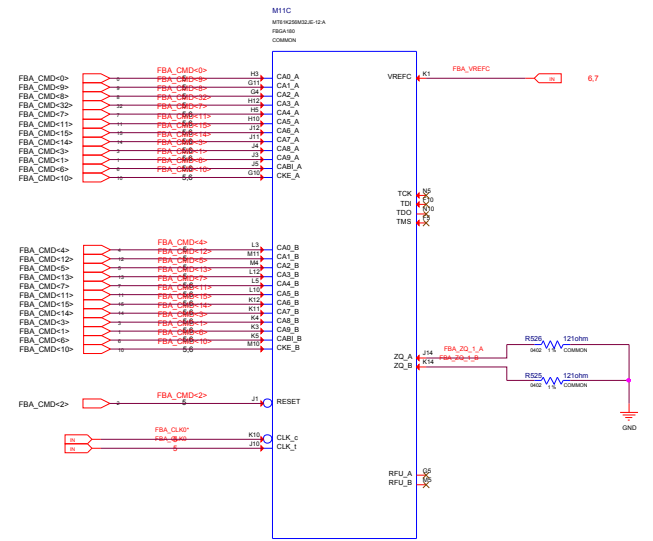
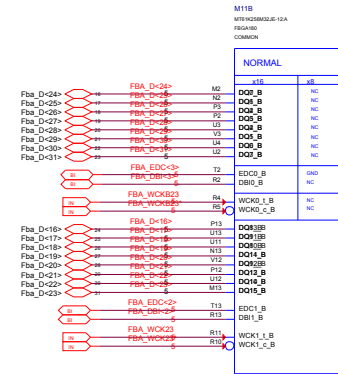
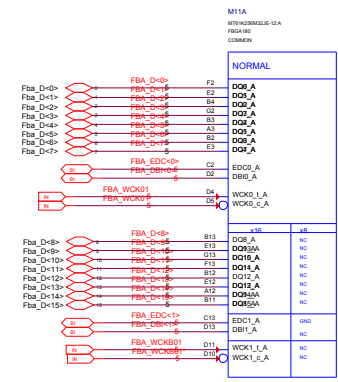
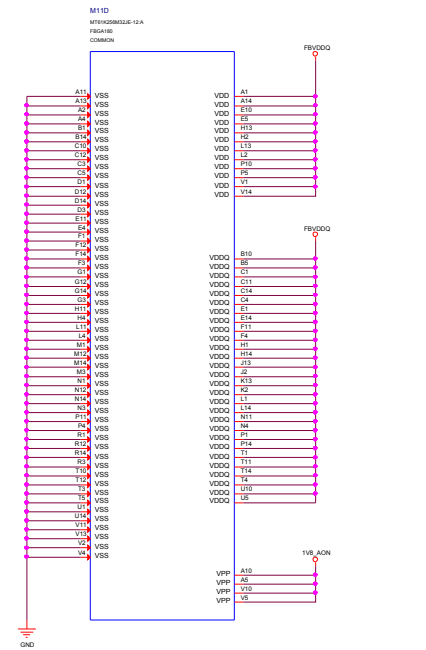

VREFC IS NOT USED IN x16 CONFIGURATION. 1K OHM PULL-DOWN IS IN PLACE OF THE 1.33K FOR R106.

MSI MICRO-STAR INT'L CO.,LTD MS-V375. Document Description: MEMORY: FBA Partition 31..0. Date: Monday, December 10, 2018. Sheet 6 of 53.

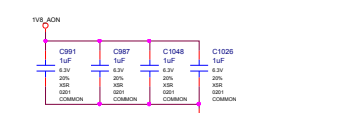
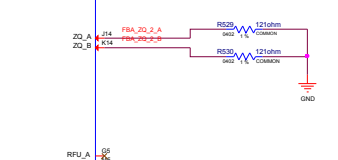
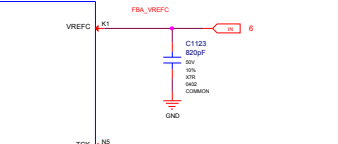
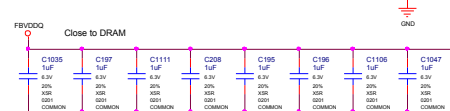
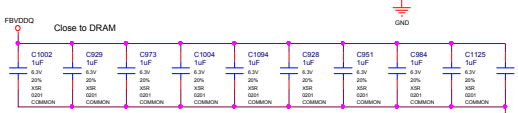
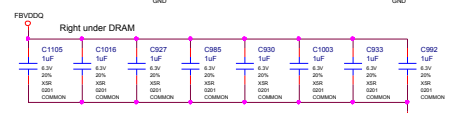
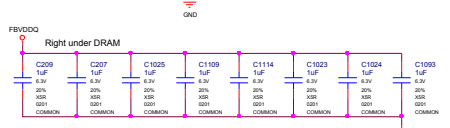
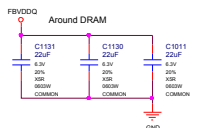
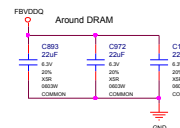
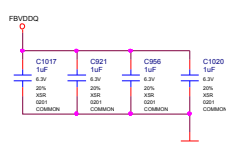
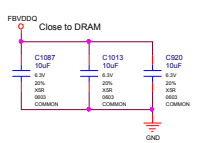
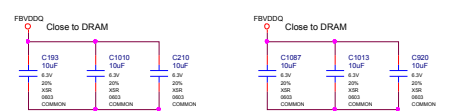
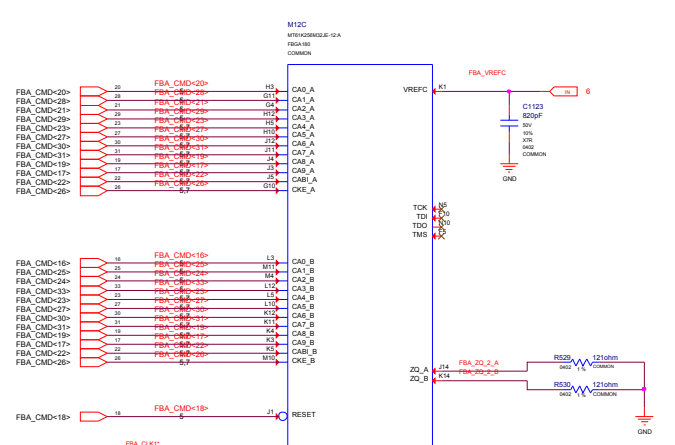
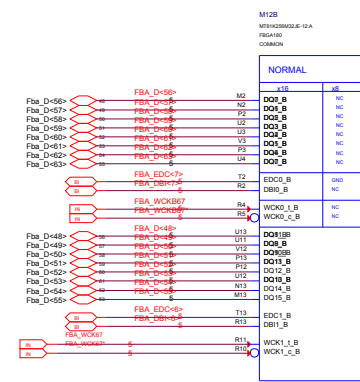
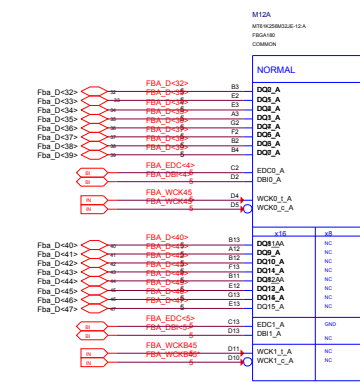
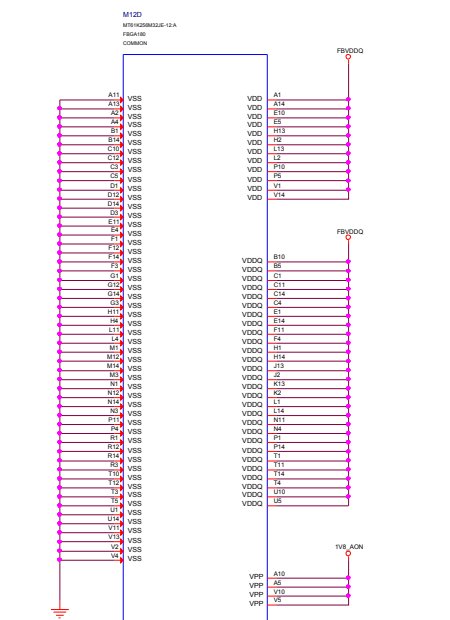

MICRO-STAR INT'L CO.,LTD
MS-V375

Size: Custom	Document Description: MEMORY: FBA Partition 63..32	Rev: 2.0
Date: Monday, December 10, 2018	Sheet: 7 of 53	

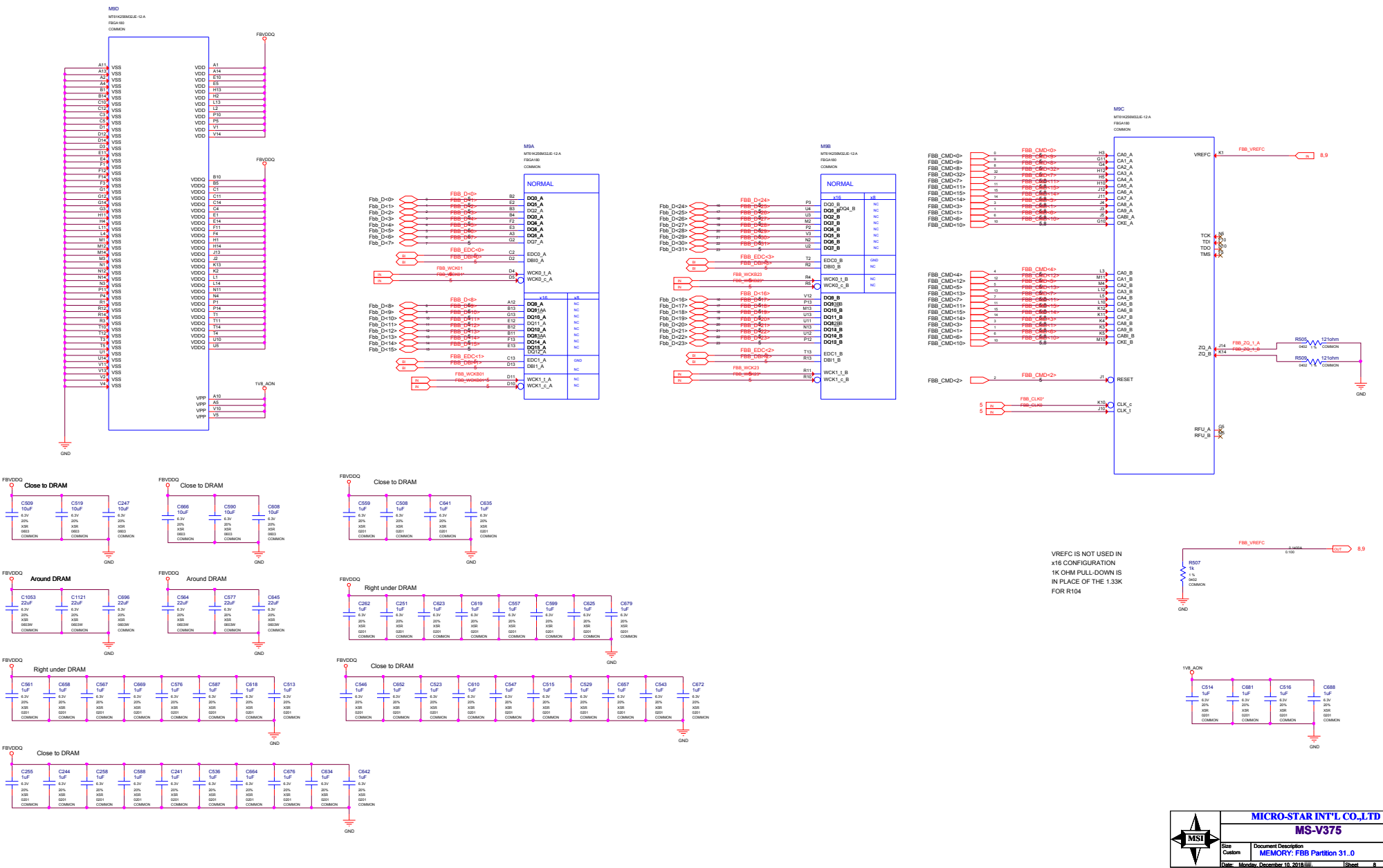

VREFC IS NOT USED IN x16 CONFIGURATION
 1K OHM PULL-DOWN IS IN PLACE OF THE 1.33K FOR R104

	MICRO-STAR INT'L CO.,LTD		Rev 2.0
	MS-V375		
Size Custom	Document Description MEMORY: FBB Partition 31..0		Sheet 8 of 53
Date: Monday, December 10, 2018 11:11			

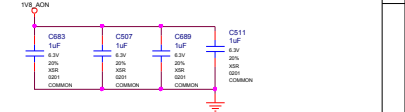
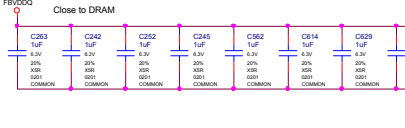
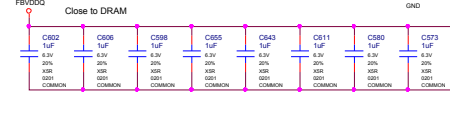
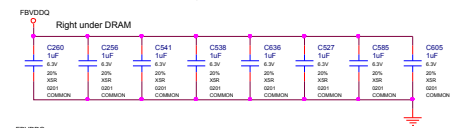
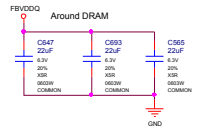
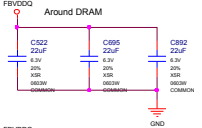
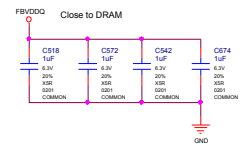
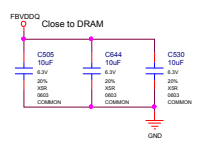
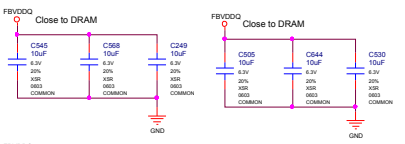
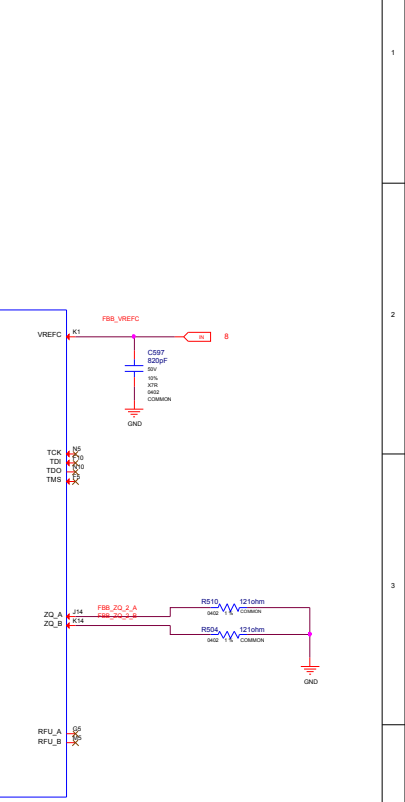
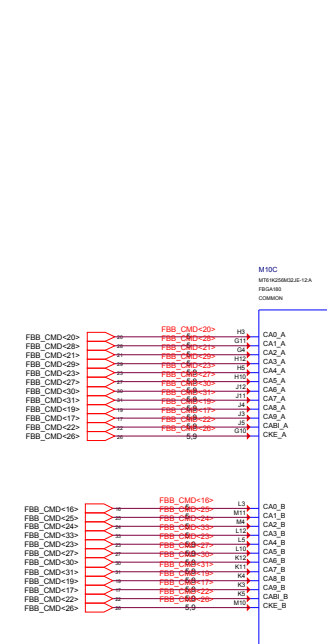
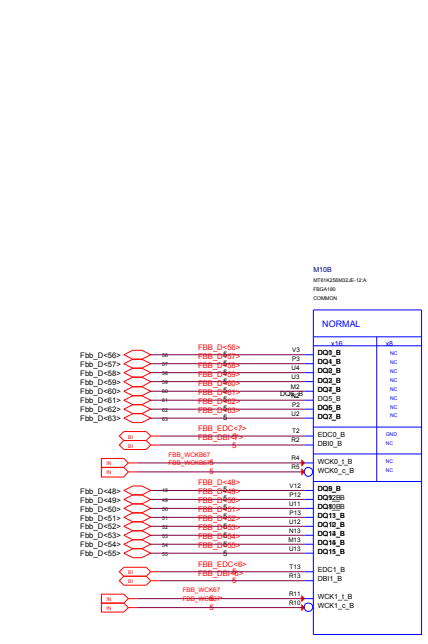
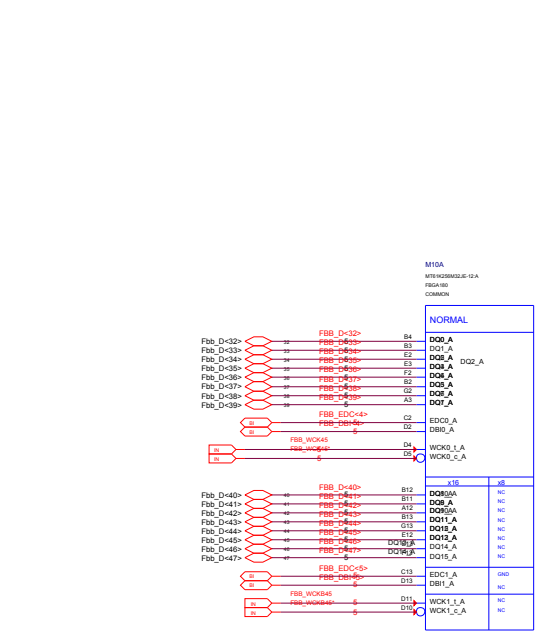
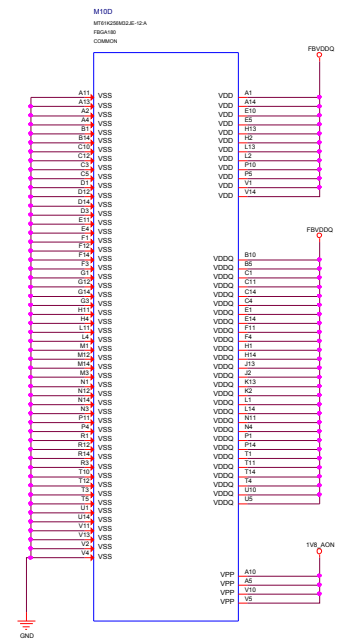

	MICRO-STAR INT'L CO.,LTD		Rev 2.0	
	MS-V375			
	Size Custom	Document Description MEMORY: FBB Partition 63..32		
	Date: Monday, December 10, 2018	Sheet 9 of 53		

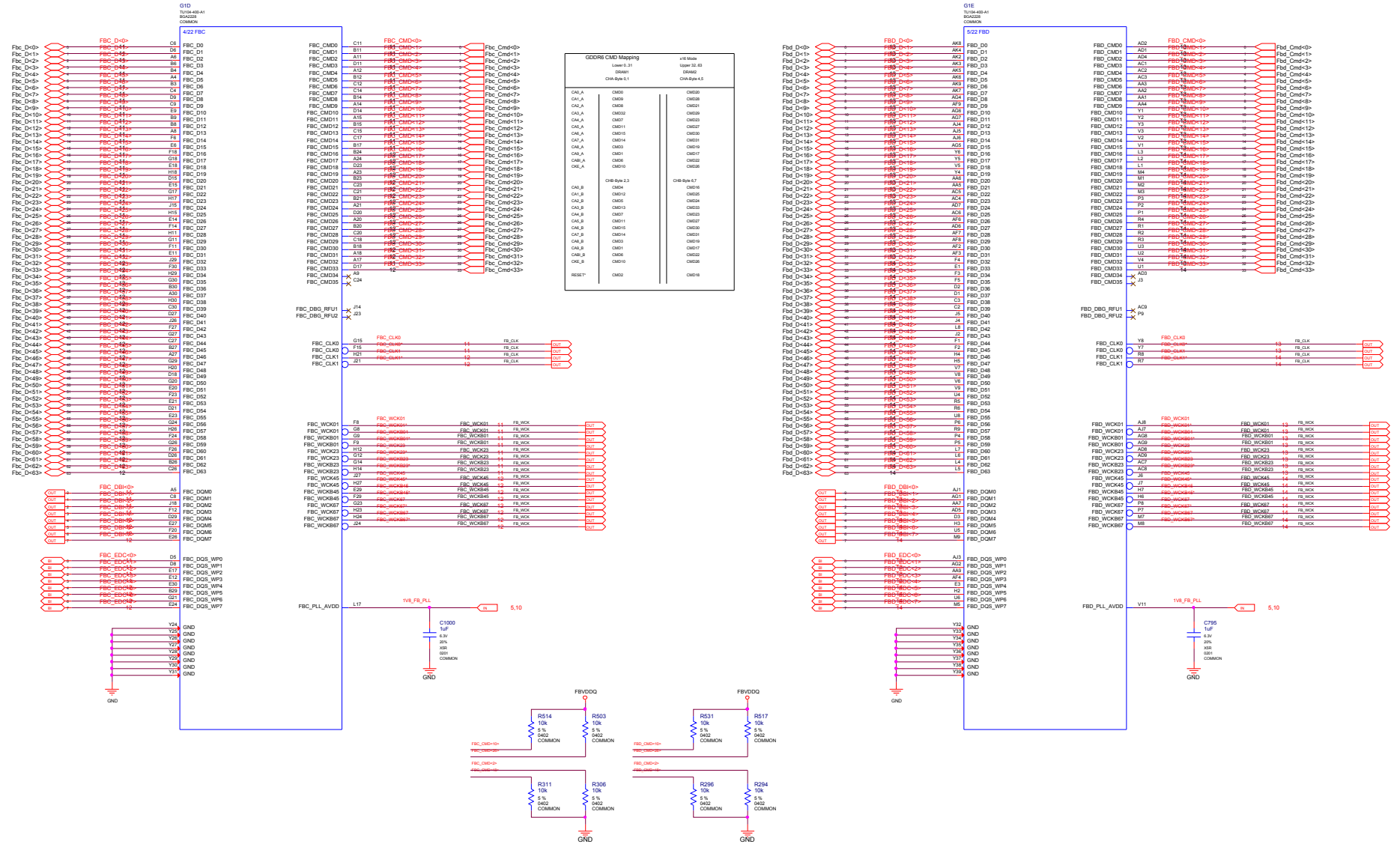

MICRO-STAR INT'L CO.,LTD
MS-V375

Size: Custom Document Description: MEMORY: GPU Partition C/D Rev: 2.0
Date: Monday, December 10, 2018 11:53 Sheet: 10 of 83

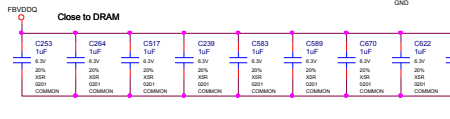
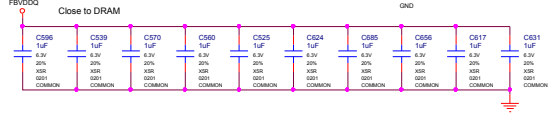
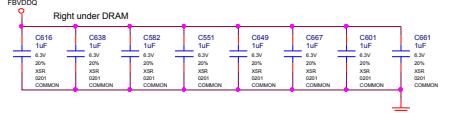
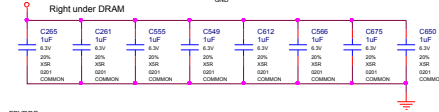
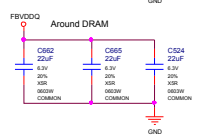
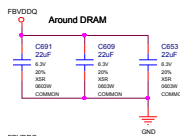
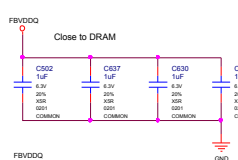
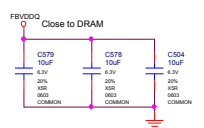
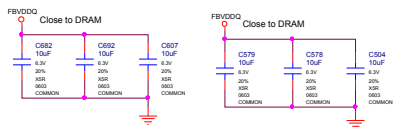
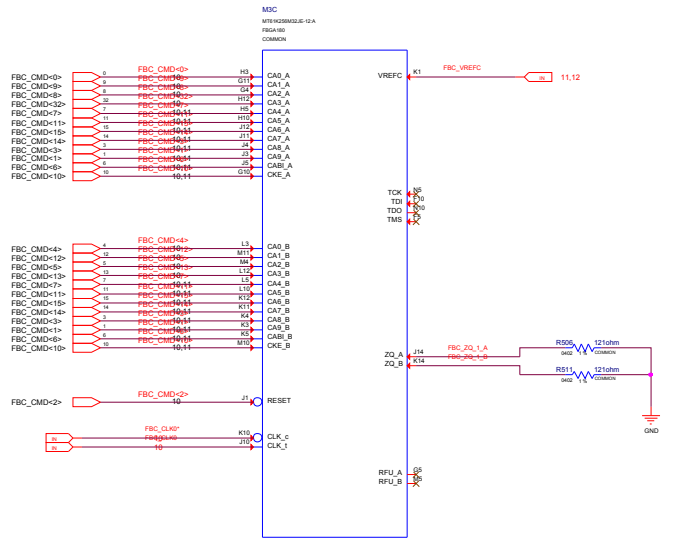
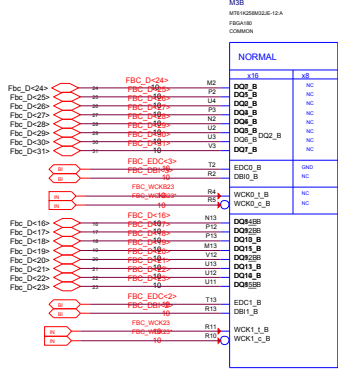
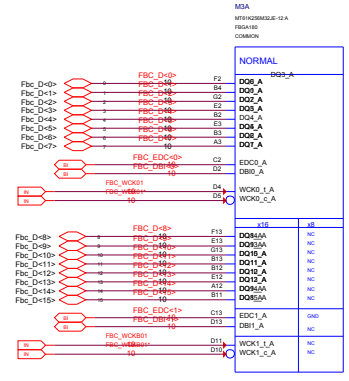
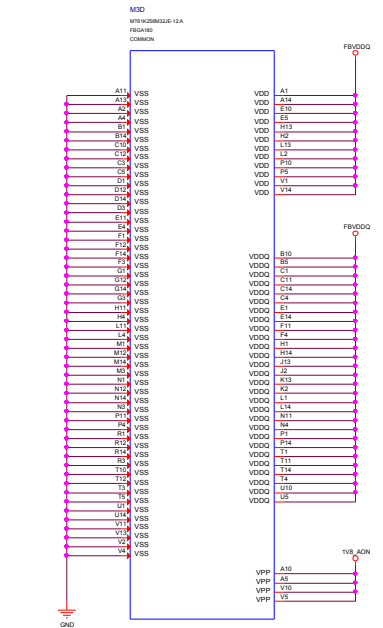

VREFC IS NOT USED IN x16 CONFIGURATION
1K OHM PULL-DOWN IS IN PLACE OF THE 1.33K FOR R75

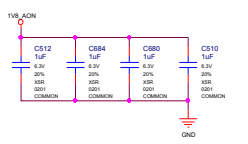
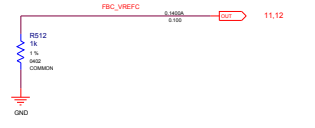

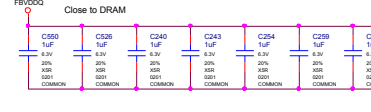
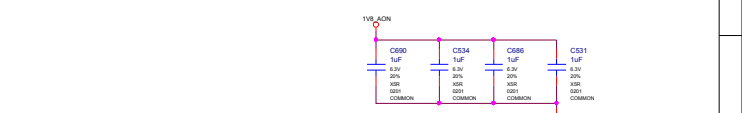
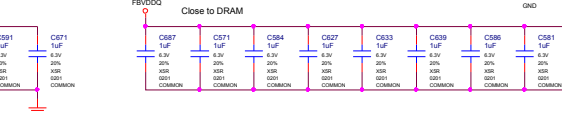
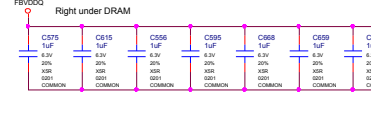
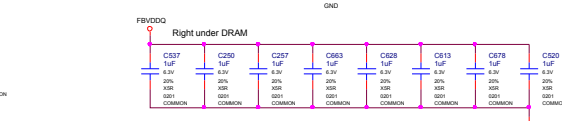
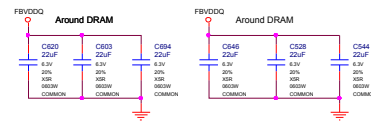
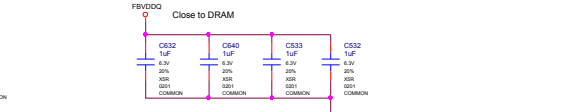
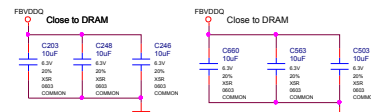
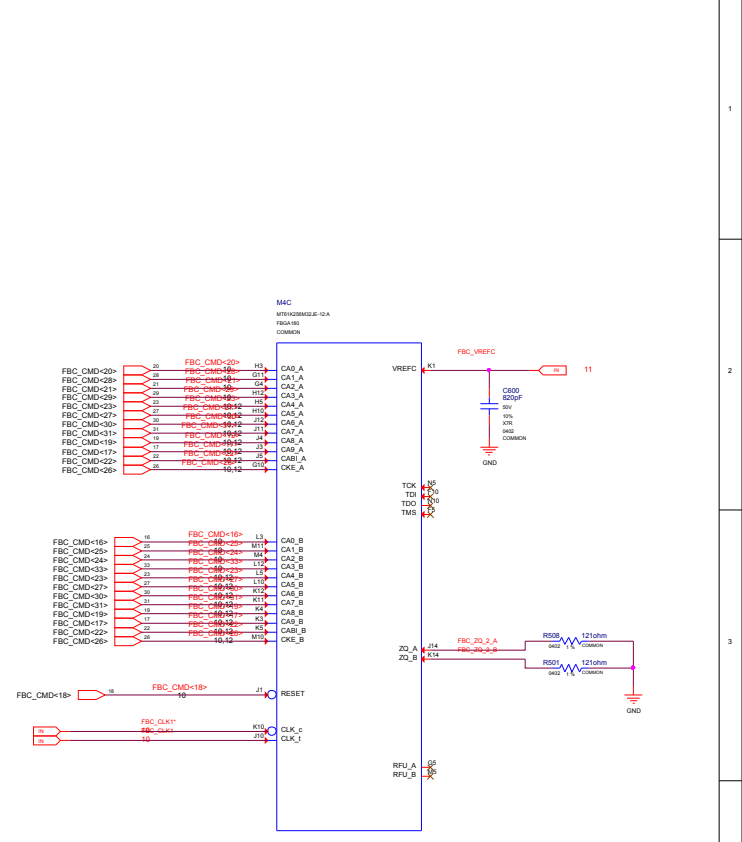
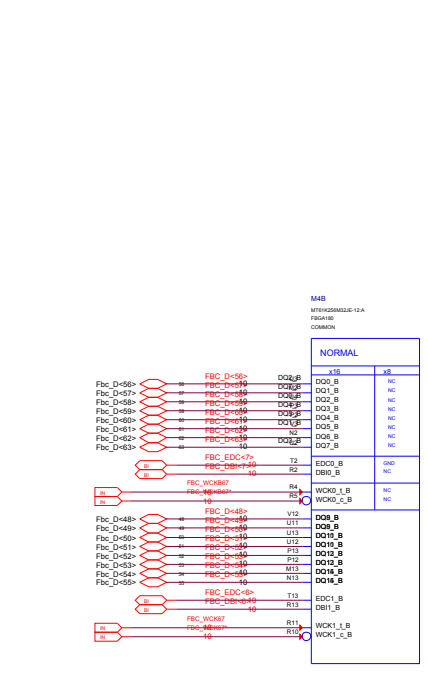
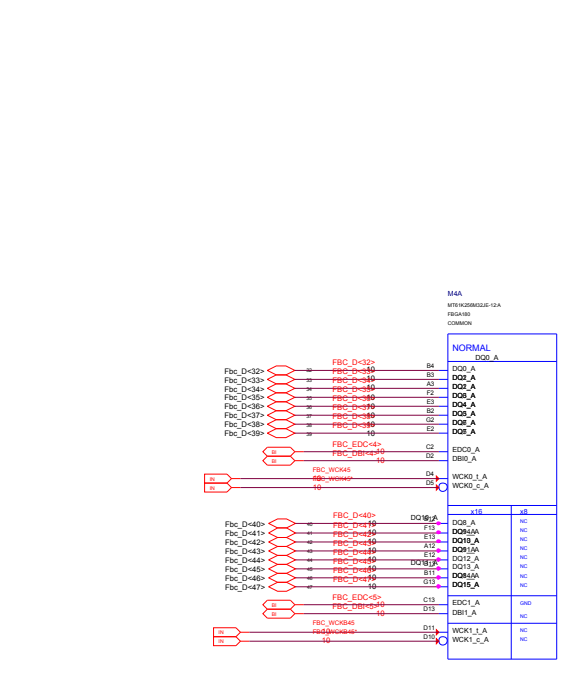
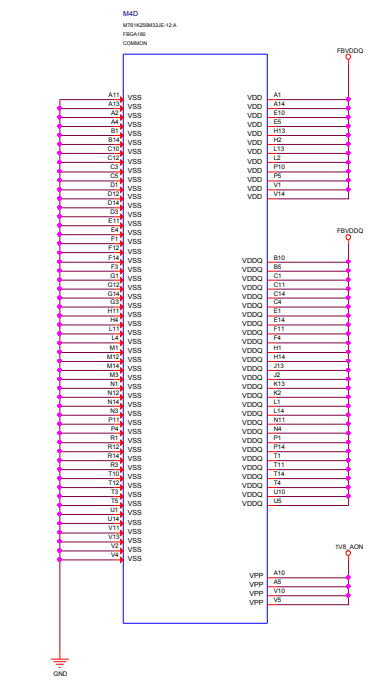

	MICRO-STAR INT'L CO.,LTD		Rev 2.0	
	MS-V375			
	Size Custom	Document Descriptor MEMORY: FBC Partition 63..32		
	Date: Monday, December 10, 2018	Sheet 12 of 53		

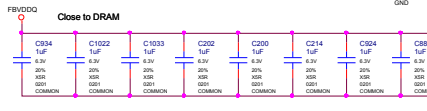
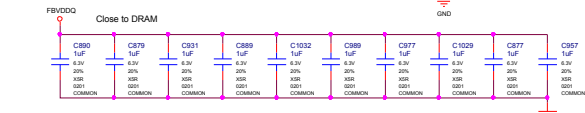
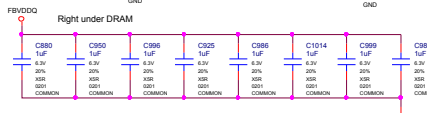
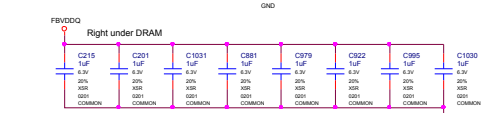
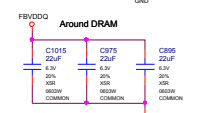
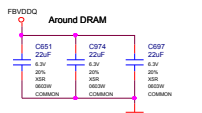
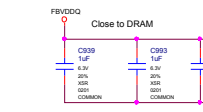
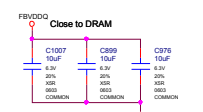
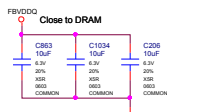
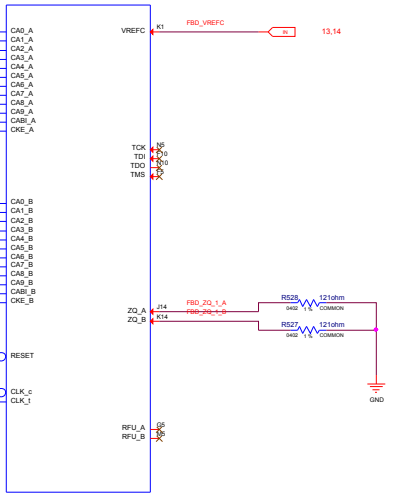
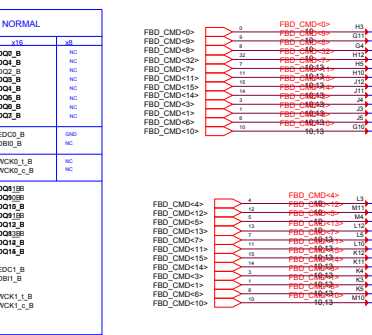
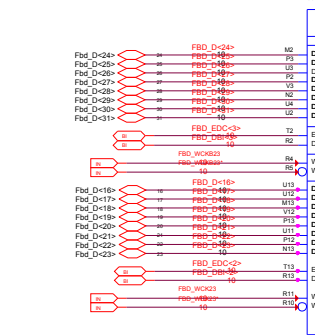
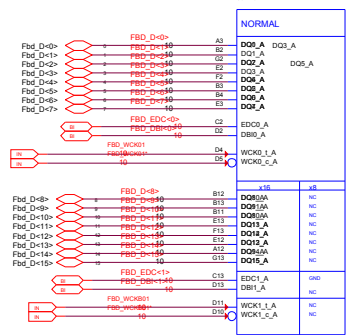
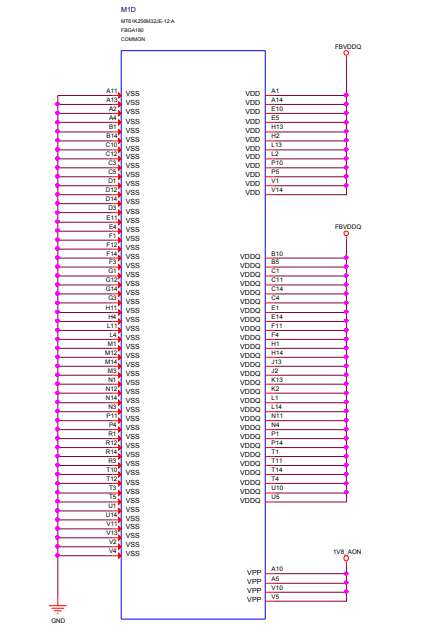

VREFC IS NOT USED IN X16 CONFIGURATION
1K OHM PULL-DOWN IS IN PLACE OF THE 1.33K FOR R62

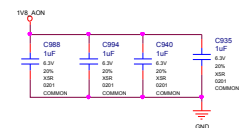
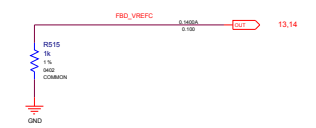

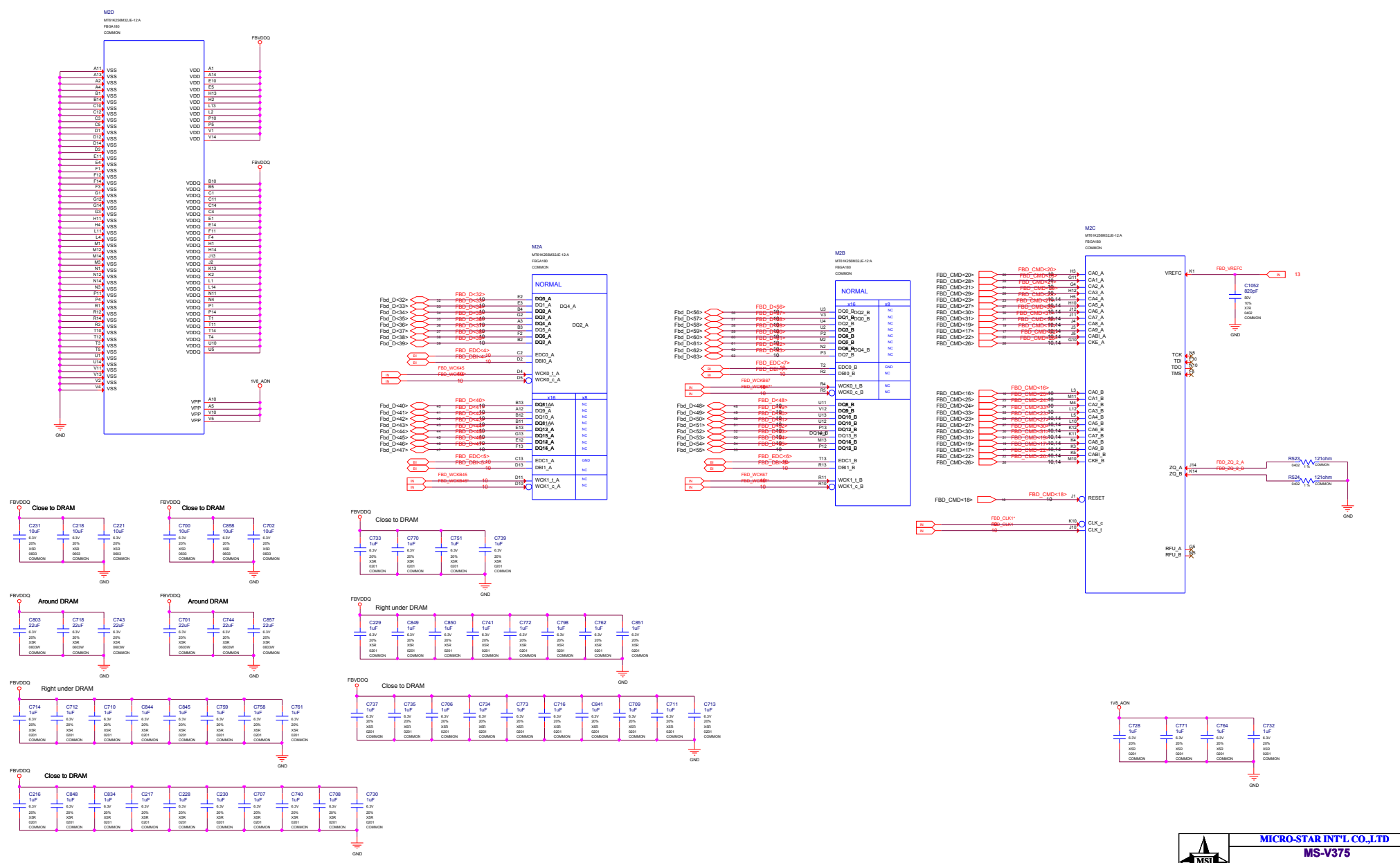

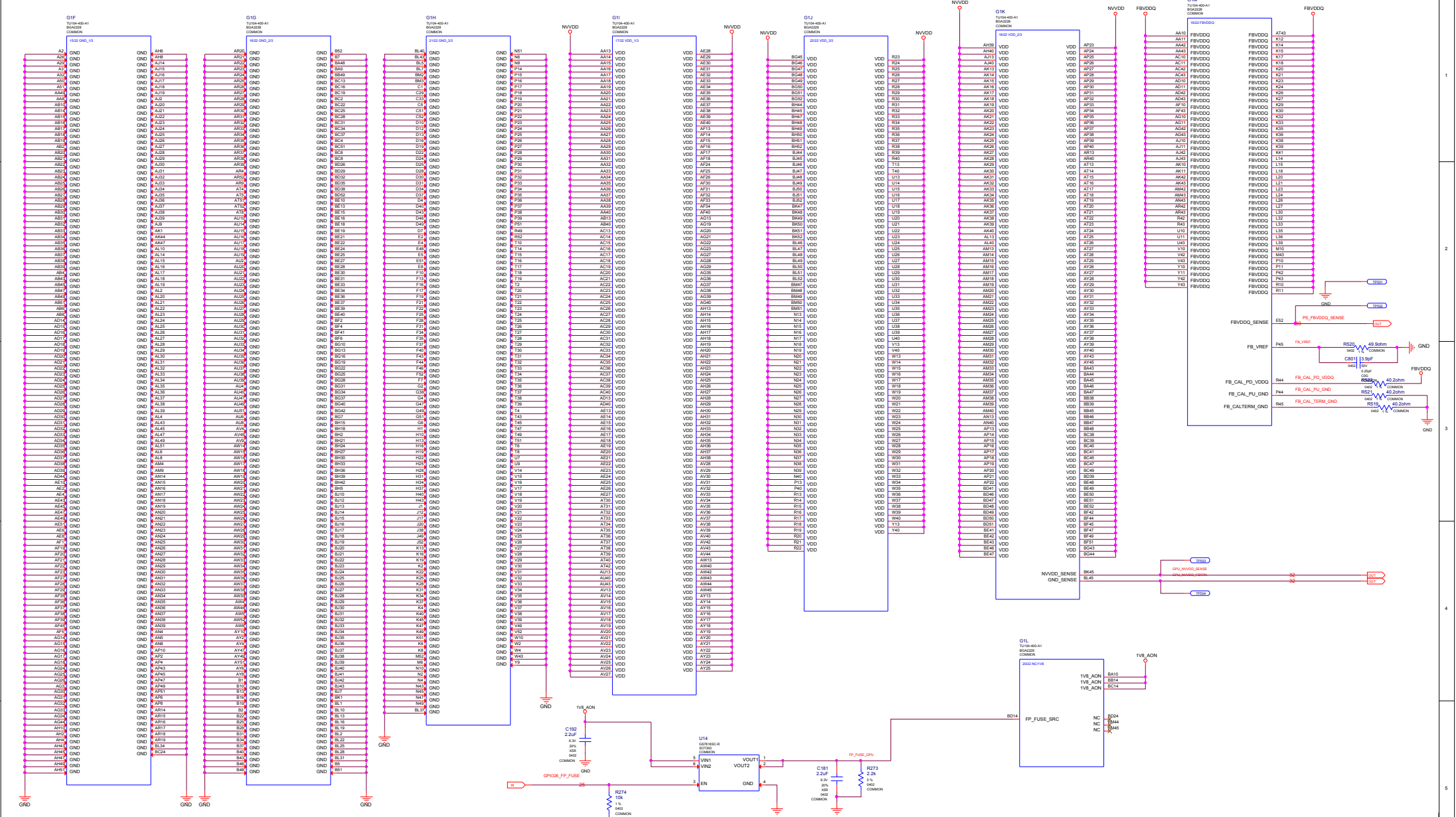

		MICRO-STAR INT'L CO., LTD MS-V375	
		Doc: Custom Date: Monday, December 10, 2018	Description: GPU PWR and GND Sheet: 15 of 63

FBVDDQ

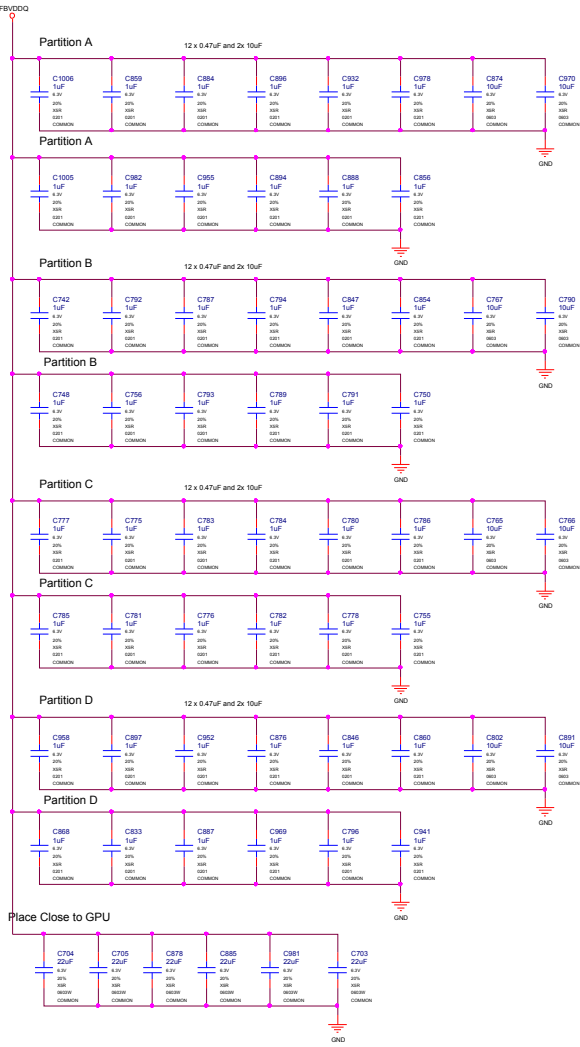

NVVDD

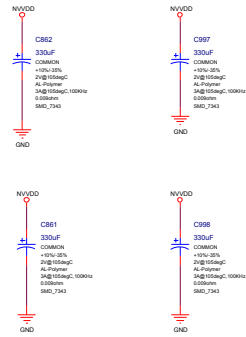

1V8_AON

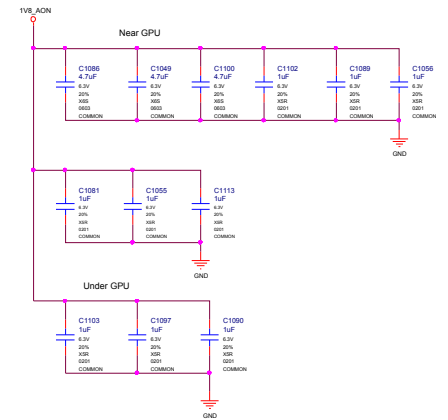

NVVD

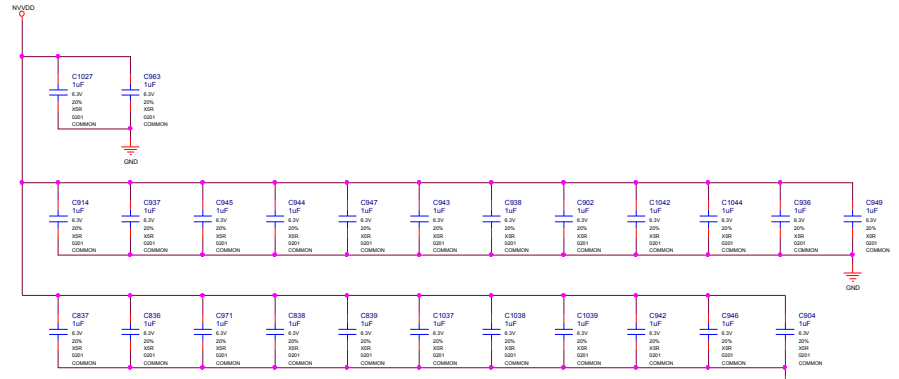
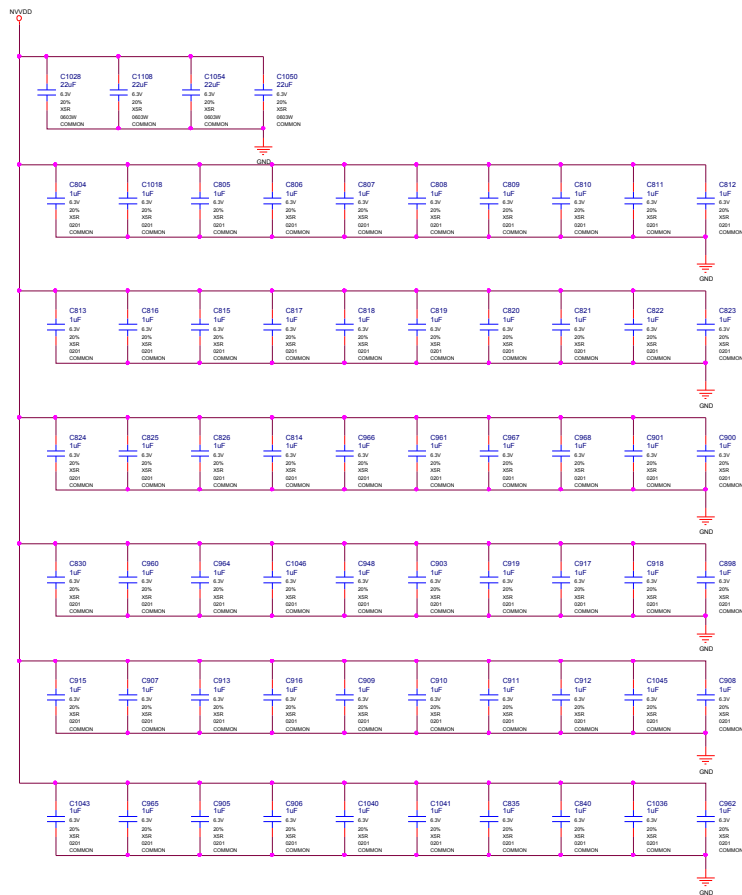

IFPAB DVI-D-DL CO-LAYOUT WITH 2x DP

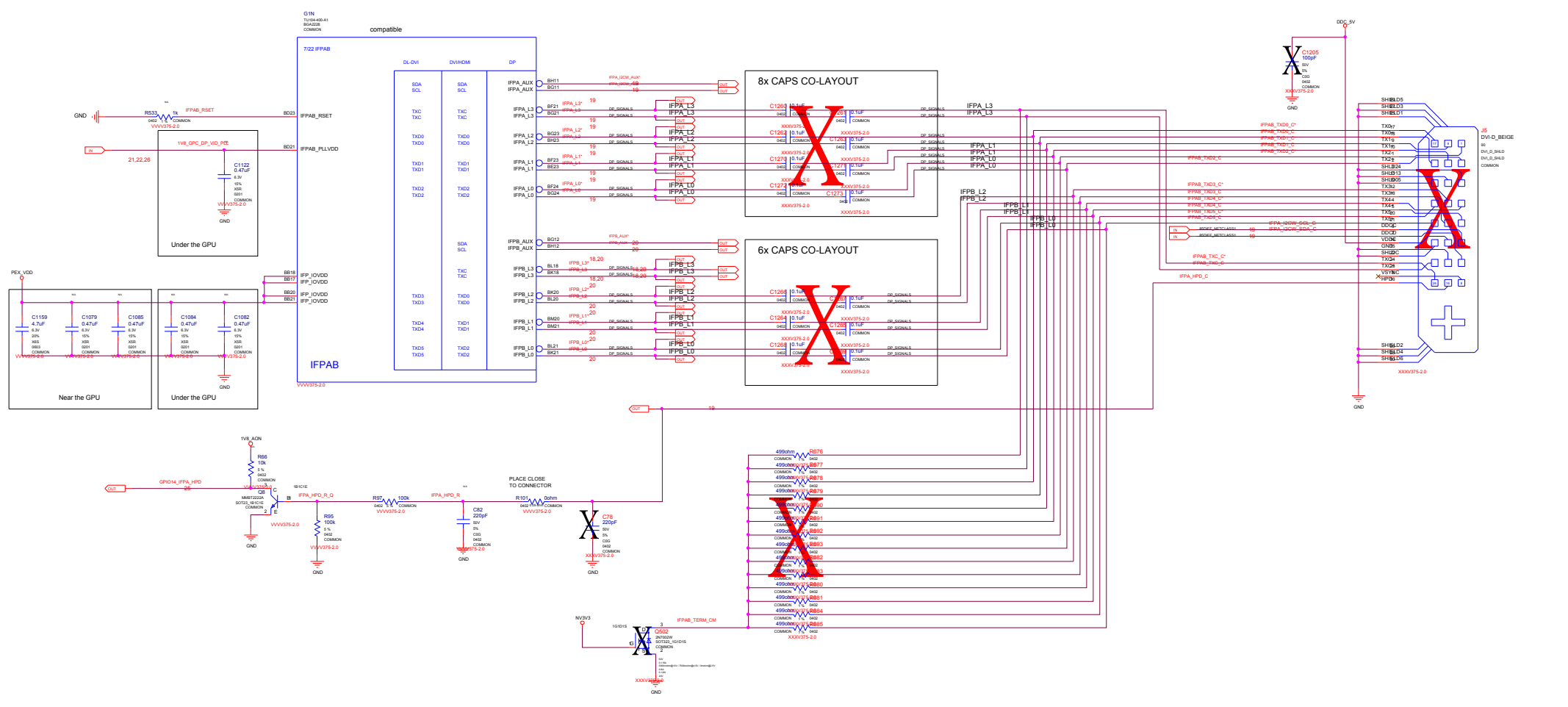

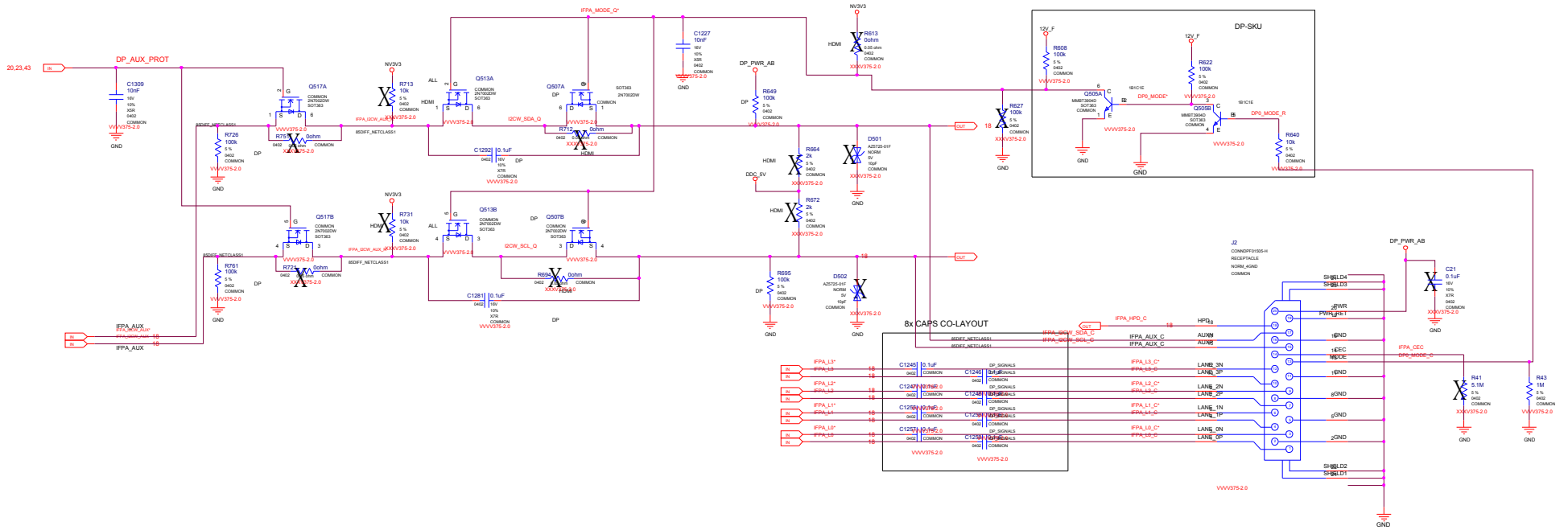

IFPA DP CO-LAYOUT WITH IFPAB DVI-D-DL

		MICRO-STAR INT'L CO.,LTD MS-V375	
Size Custom	Document Description IFPA DP	Rev. 2.0	
Date: Monday, December 10, 2018		Sheet 19 of 33	

IFPB DP CO-LAYOUT WITH IFPAB DVI-D-DL

- Two cases to be considered:
1. DP AUX to DP connector: AUX AC coupled
 2. DP AUX to DP-DVI dongle: AUX pass through

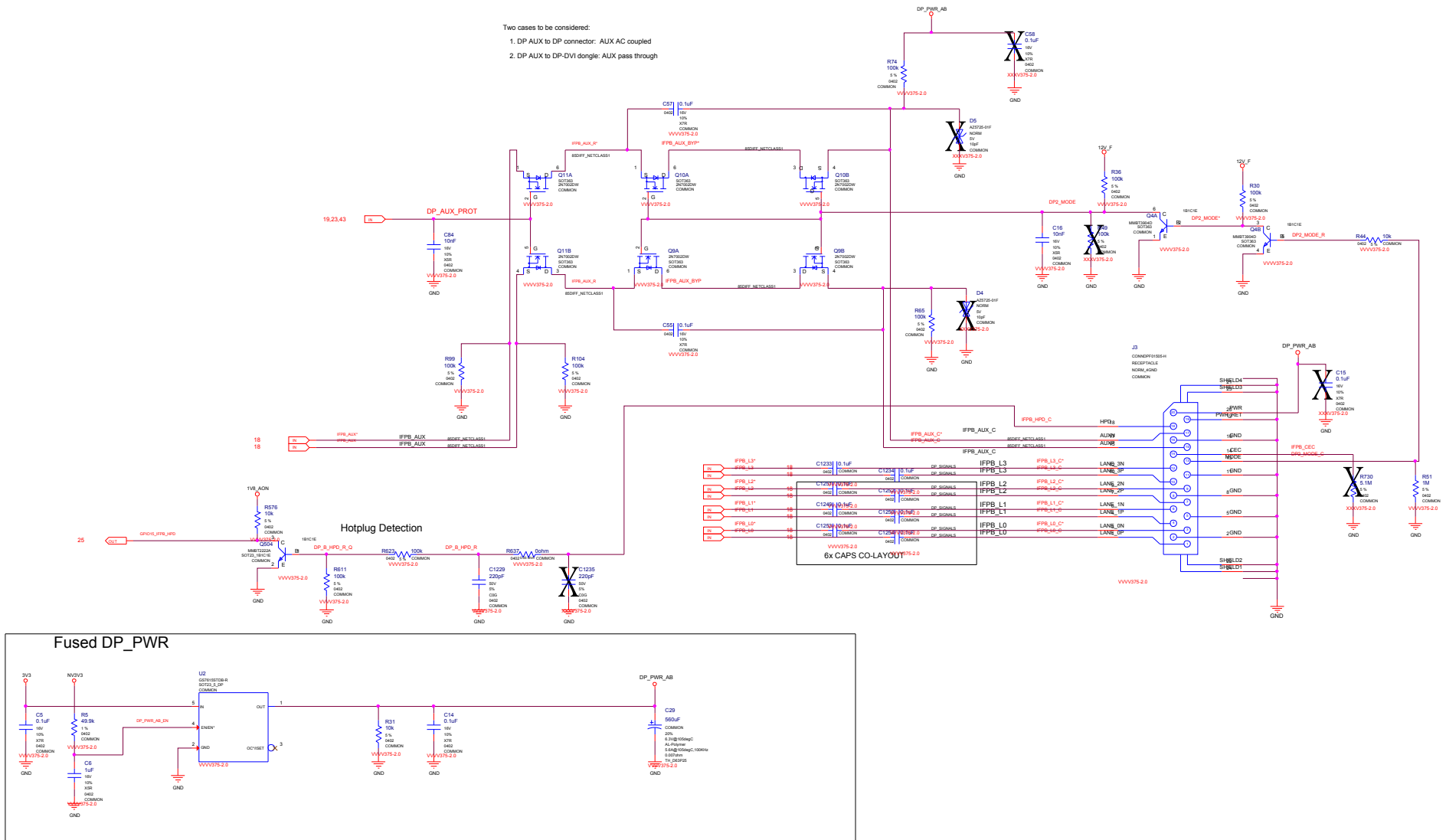

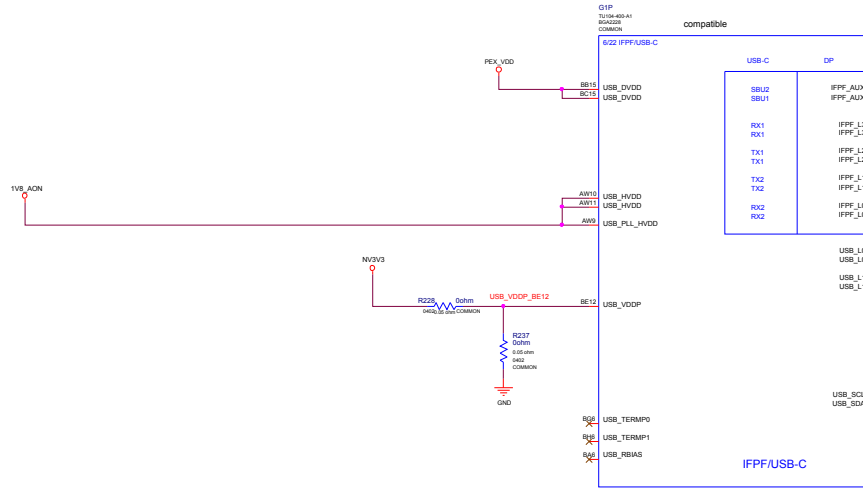

IFPF NC

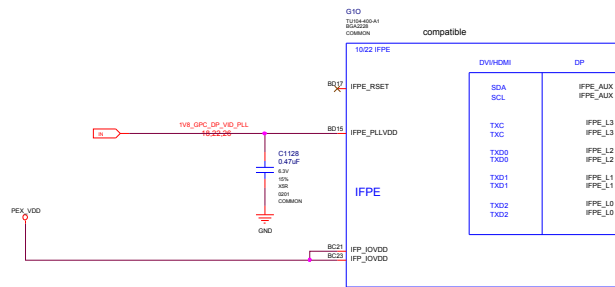

IFPE NC

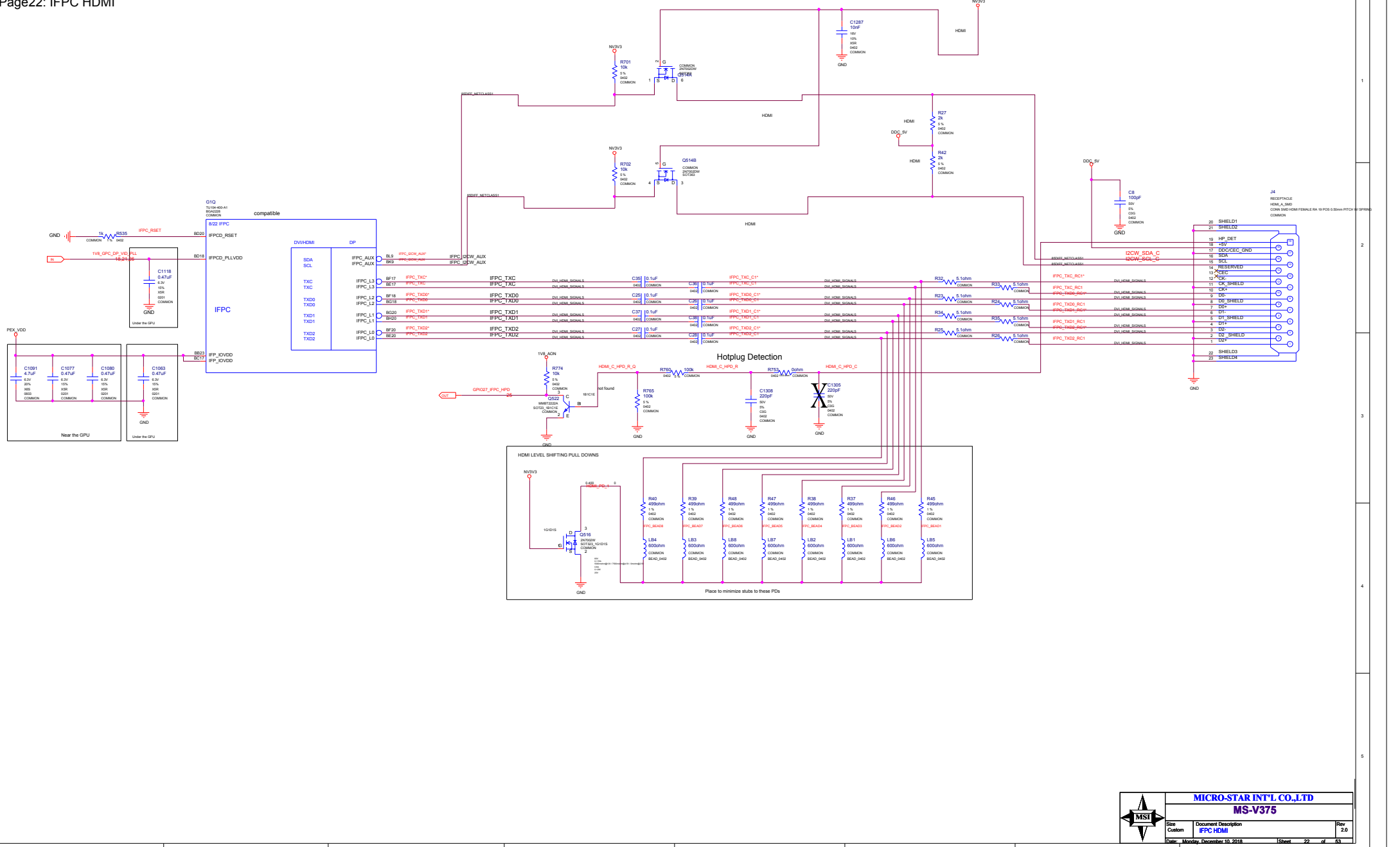

MICRO-STAR INT'L CO., LTD.			
MS-V375			
Size: Custom	Document Description: IFPC HDMI	Rev: 2.0	
Date: Monday, December 10, 2018	Sheet: 22 of 53		

Two cases to be considered:
 1. DP AUX to DP connector: AUX AC coupled
 2. DP AUX to DP-DVI dongle: AUX pass through

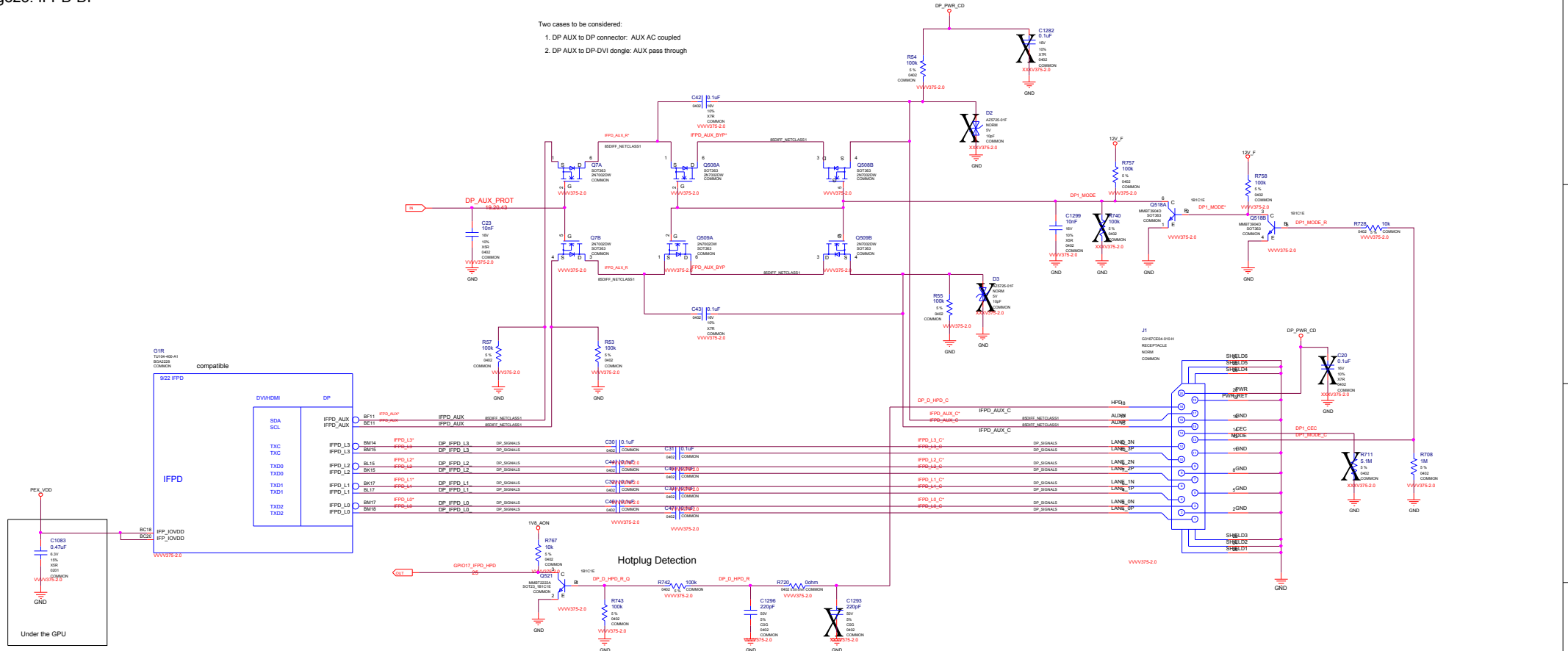

Fused DP_PWR

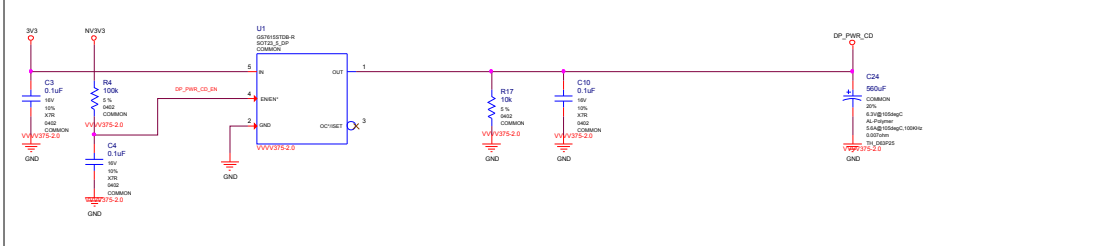

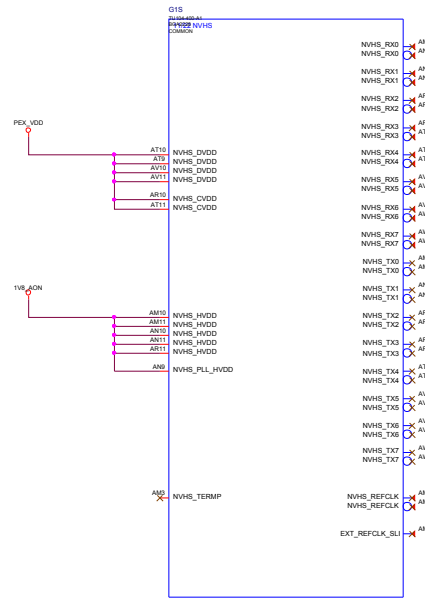

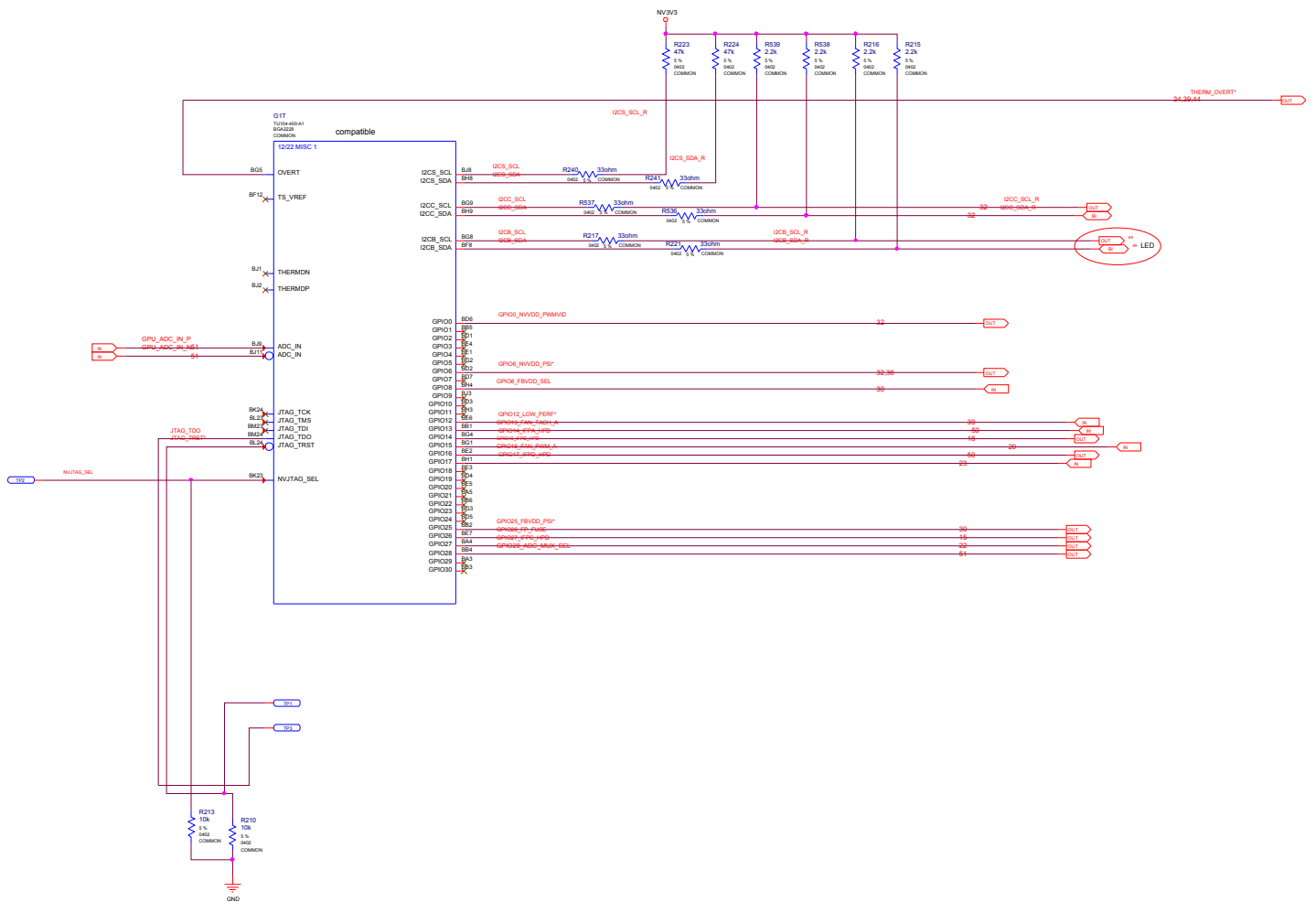

STRAP2	STRAP1	STRAP0	RAMCFG[4:0]
L	L	L	00000
L	L	H	00001
L	H	L	00010
L	H	H	00011
H	H	L	00110
H	H	H	00111
L	L	M	01000

RAMCFG[4:0]	DENSITY	WIDTH	VENDOR	DIE
00000	8Gb	256-bit	Samsung	C
00001	8Gb	256-bit	Micron	A
00010	8Gb	256-bit	Hynix	M
00011	8Gb	256-bit	Samsung	C
00100	8Gb	256-bit	Micron	A
00101	8Gb	256-bit	Hynix	M
00110	16Gb	256-bit	Samsung	M
00111				

ROM_SO	ROM_SI	ROM_SCLK	DUMMY[2:0].FS_OVERT	1.ENABLE 0.DISABLE	DEFAULT
L	L	L	XXX1	FS_OVERT ENABLE	DEFAULT
L	L	M	XXX0	FS_OVERT DISABLE	

STRAP5	STRAP4	STRAP3	SMB_ALT_ADDR	DEVID_SEL	PCI_CFG	VGA_DEVICE
M	H	H	1	1	1	1
M	H	L	1	1	1	0
M	L	H	1	1	0	1
M	L	L	1	1	0	0
L	H	M	1	0	1	1
L	M	H	1	0	1	0
L	M	L	1	0	0	1
L	L	M	1	0	0	0
H	H	H	0	1	1	1
H	H	L	0	1	1	0
H	L	H	0	1	0	1
H	L	L	0	1	0	0
L	H	H	0	0	1	1
L	H	L	0	0	1	0
L	L	H	0	0	0	1 DEFAULT
L	L	L	0	0	0	0

H=High :Tied to 1.8V
M=Middle:Tied to 0.9V
L=Low :Tied to 0V

1:SMB_ALT_ADDR ENABLE
0:SMB_ALT_ADDR DISABLE
1:DEVID_SEL REBRAND
0:DEVID_SEL ORIGINAL

1:PCI_CFG LOW POWER
0:PCI_CFG HIGH POWER
1:VGA_DEVICE ENABLE
0:VGA_DEVICE DISABLE

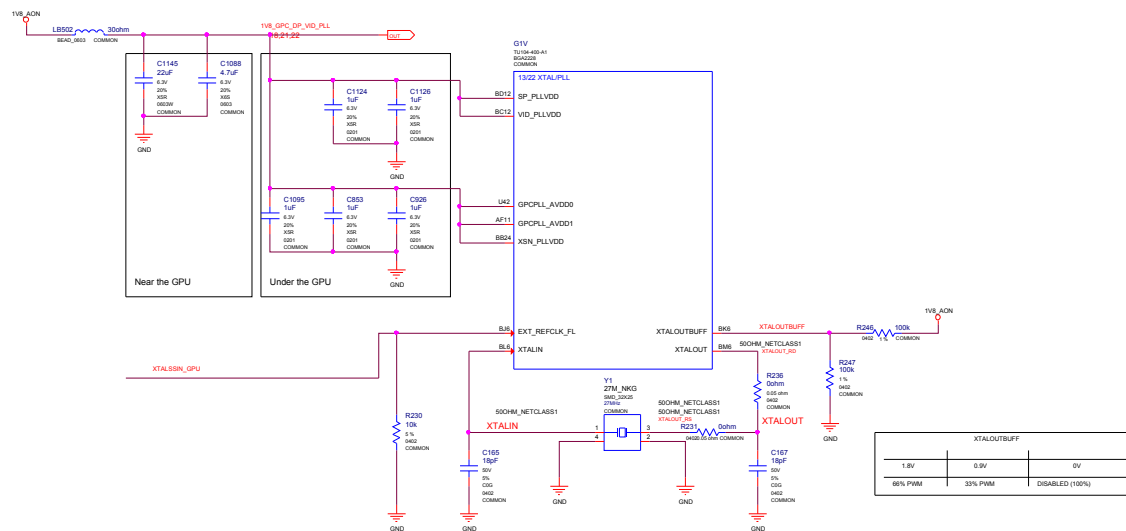
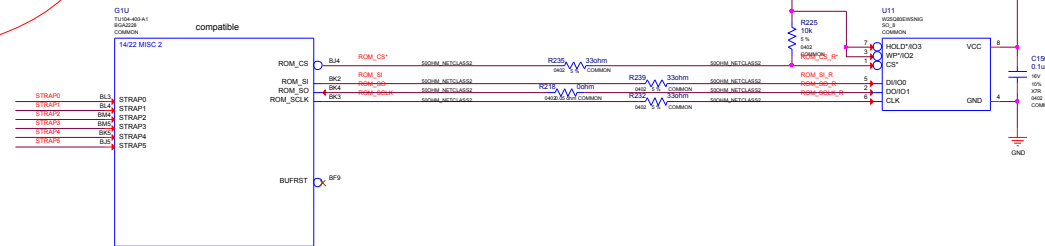
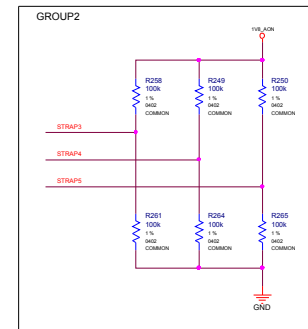
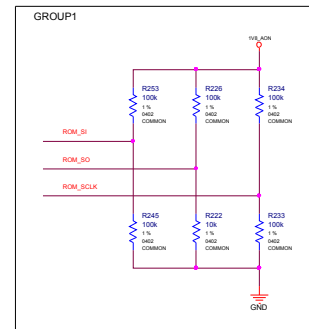
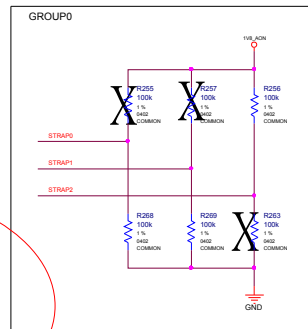
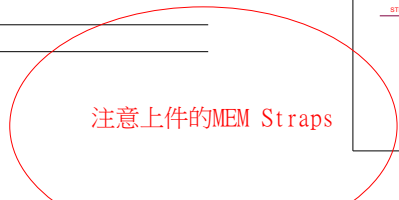

XTALOUT/BUFF		
1.8V	0.9V	0V
66% PWM	33% PWM	DISABLED (100%)

MSI MICRO-STAR INT'L CO.,LTD
MS-V375
Date: Monday, December 16, 2016 Sheet 26 of 63

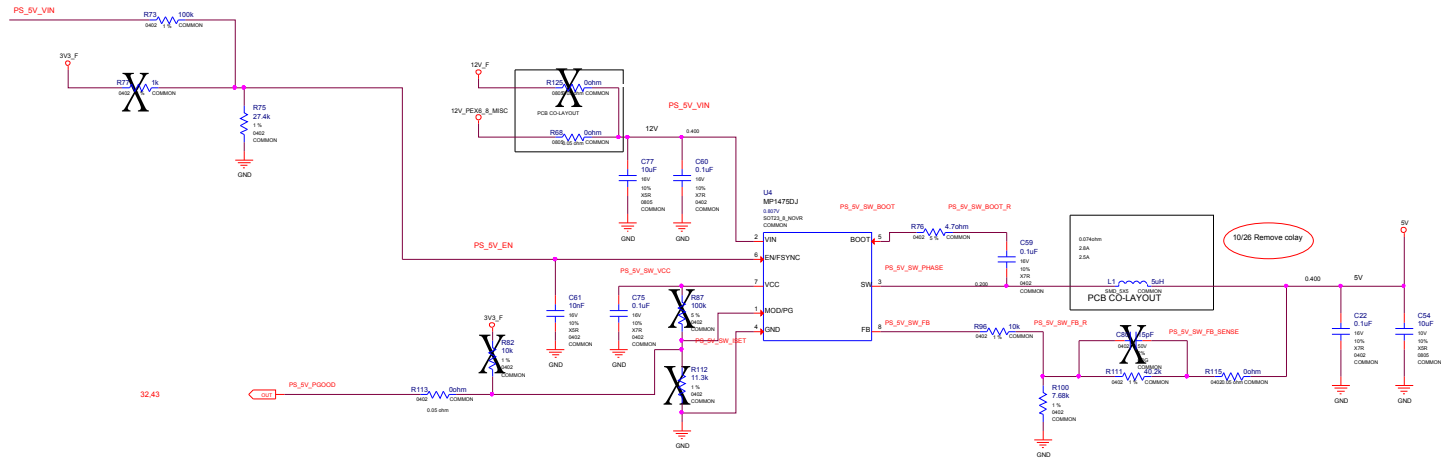

$$0.8V * (1 + 40.2K / 7.68K) = 4.9875V$$

PEX Switcher

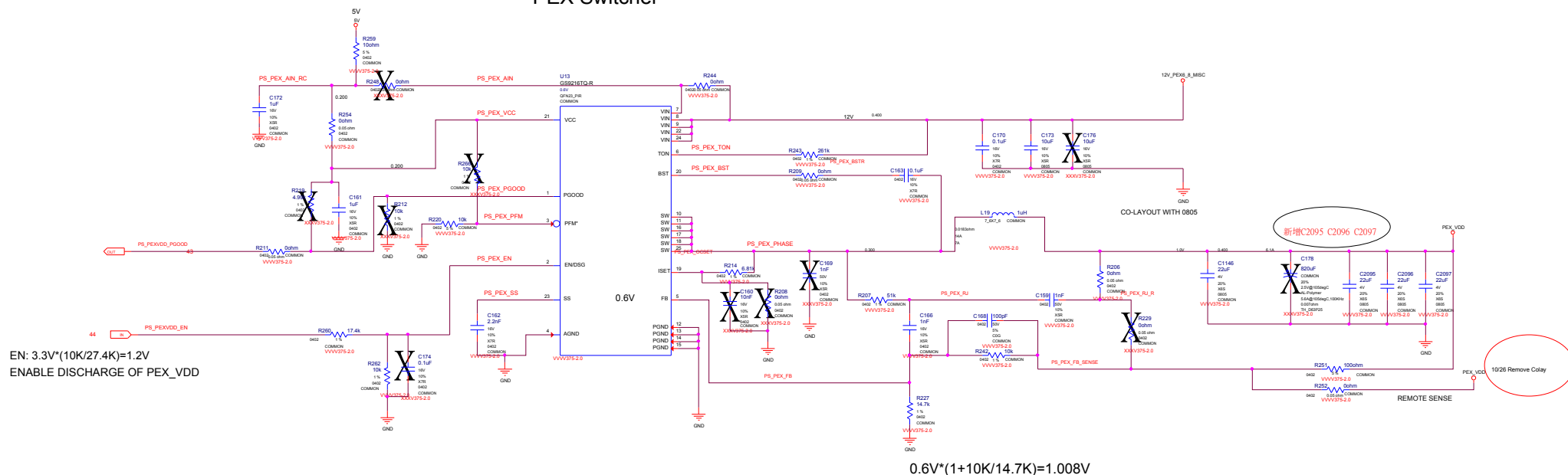

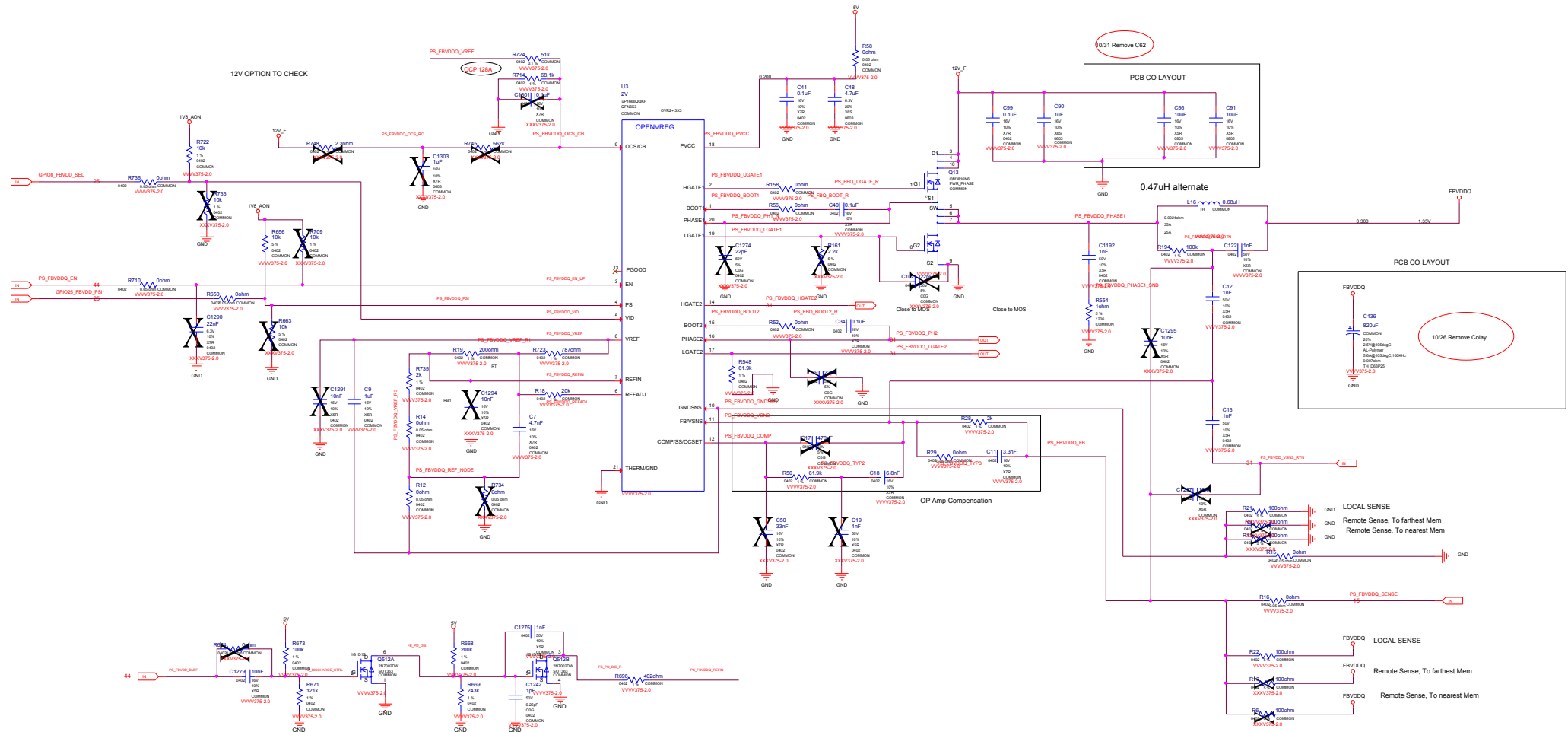

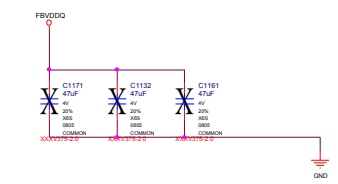
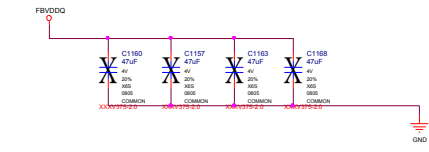
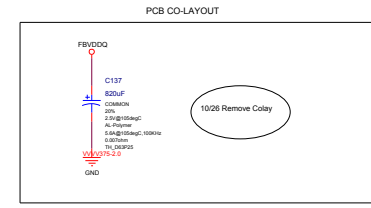
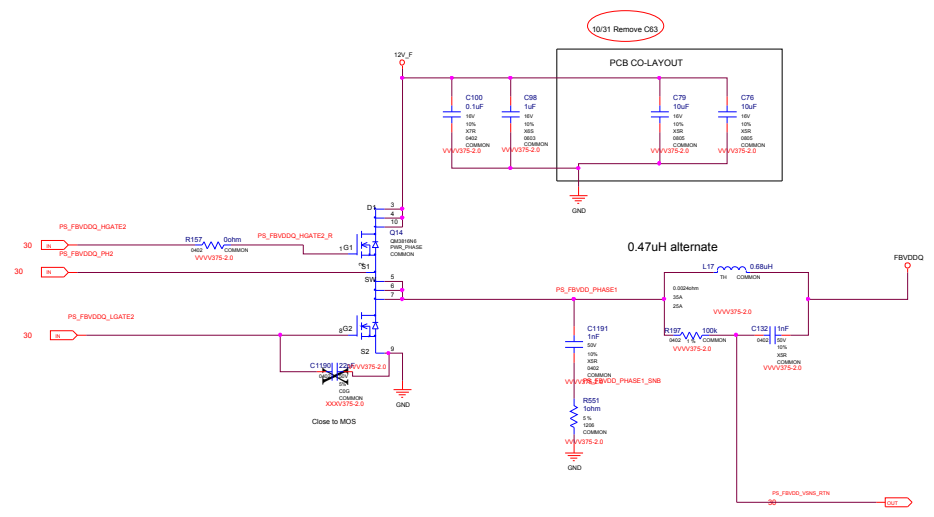

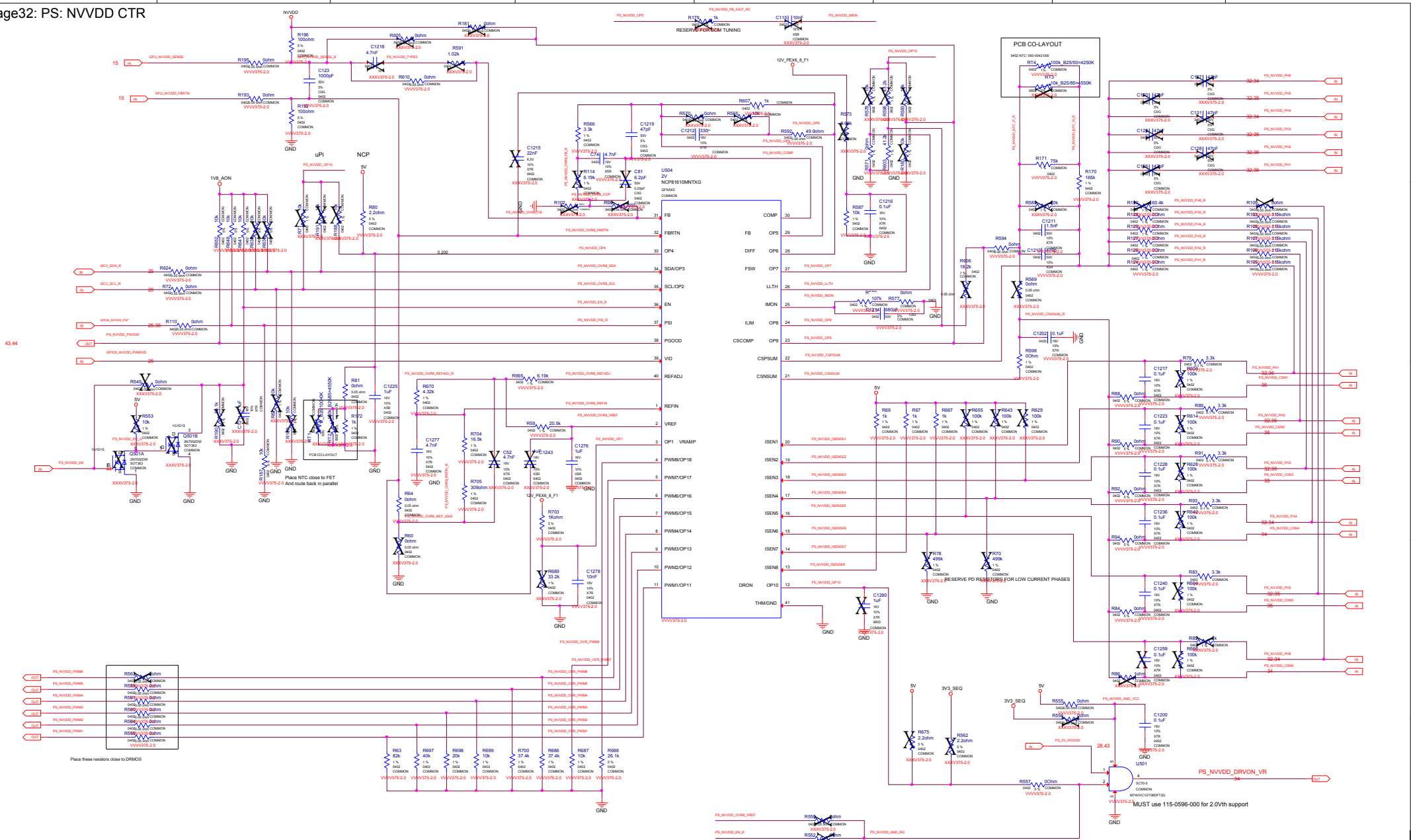

43.44

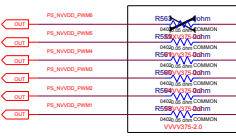

Place these resistors close to DRMONS

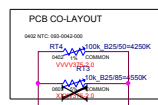

MUST use 115-0596-000 for 2.0Vth support

	MICRO-STAR INT'L CO.,LTD		MS-V375
	Size Custom	Document Description PS: NVVDD CTR	Rev 2.0
	Date: Monday, December 10, 2018		Sheet 32 of 53

1
2
3
4
5

DROP OVR3i SOLUTION

	MICRO-STAR INT'L CO.,LTD	
	MS-V375	
Size Custom	Document Description PS: NVVDD CTR OVR3i	Rev 2.0
Date: Monday, December 10, 2018		Sheet 33 of 53

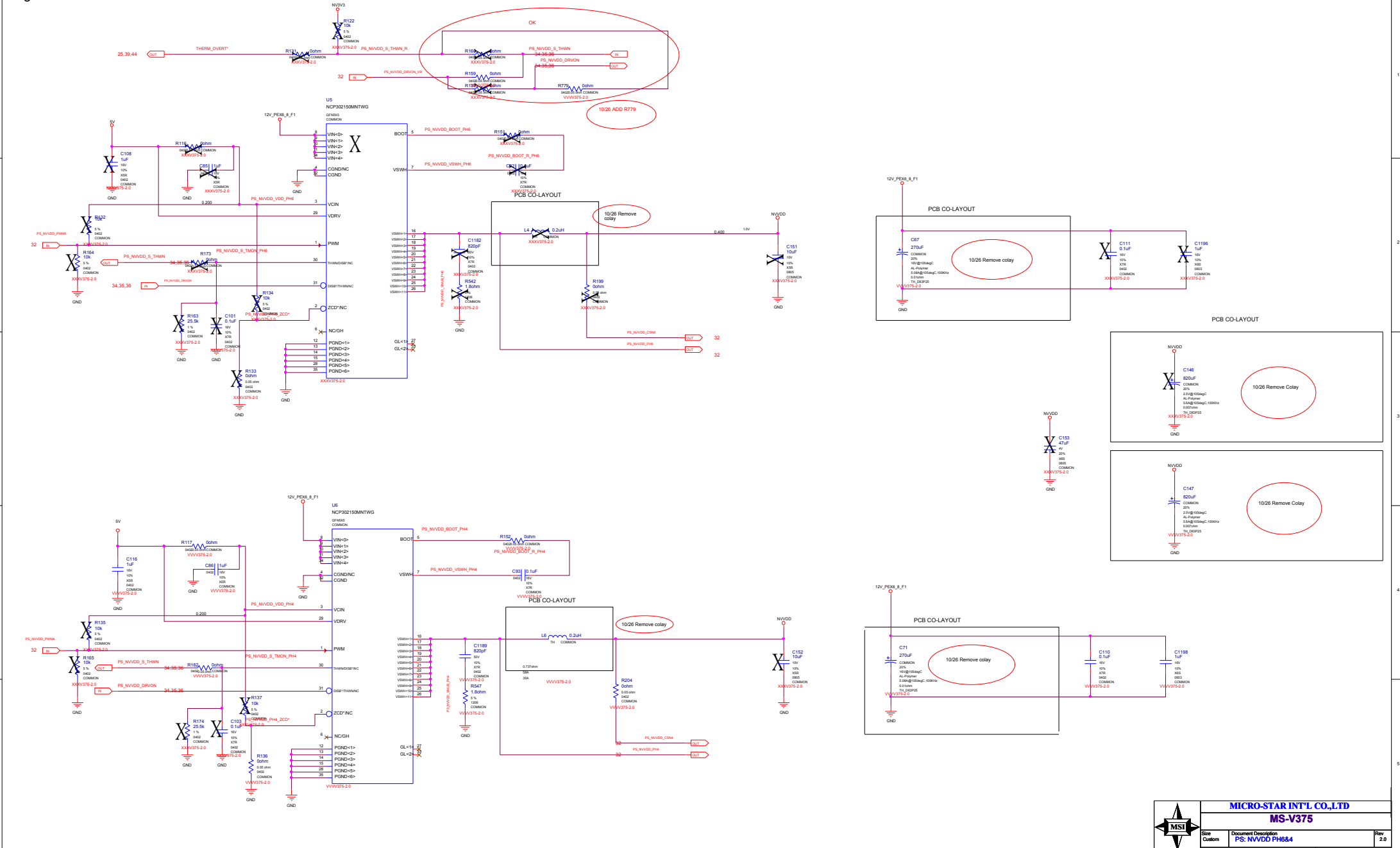

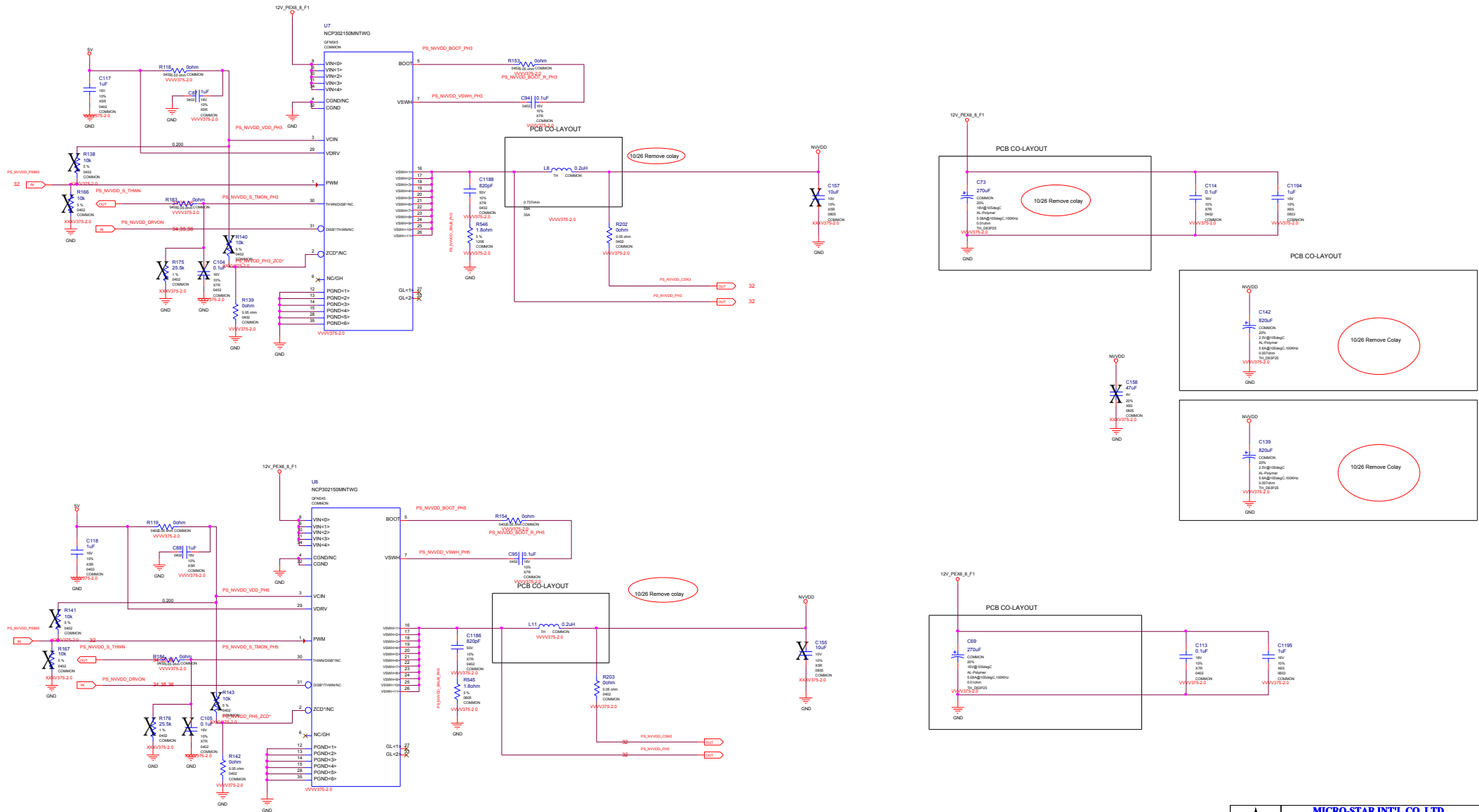

	MICRO-STAR INT'L CO.,LTD	
	MS-V375	
Size: Custom	Document Description: PS: NVVDD PH3&5	Rev: 2.0
Date: Monday, December 10, 2018		Sheet: 35 of 63

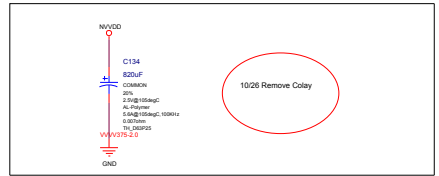
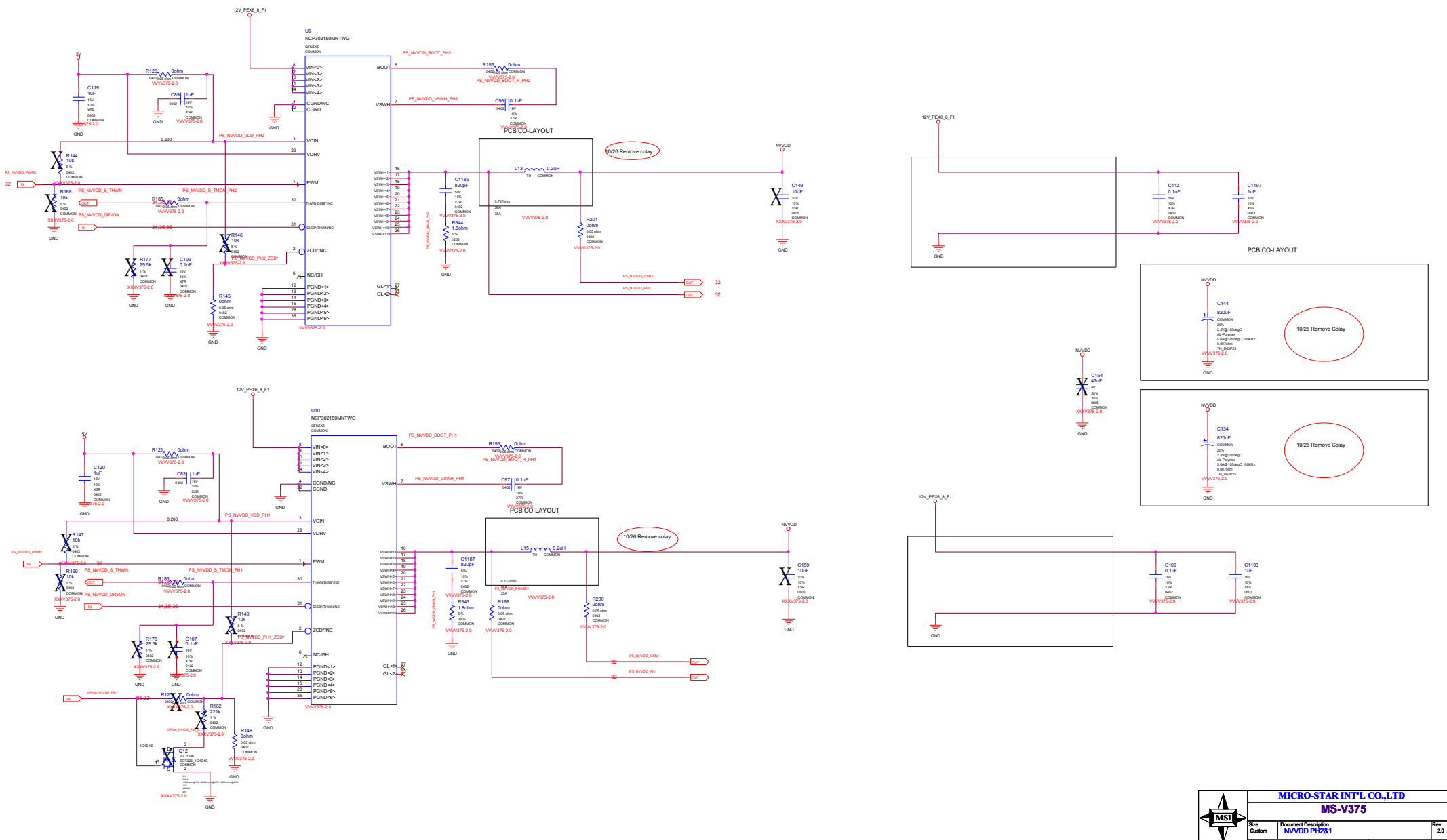

MICRO-STAR INT'L CO.,LTD		
MS-V375		
Size: Custom	Documen Description: NVVDD PH2&1	Rev: 2.0
Date: Monday, December 10, 2018	Sheet: 36	of: 63

1

1

2

2

DELETE RAIL BALANCE CIRCUIT

3

3

4

4

5

5

	MICRO-STAR INT'L CO.,LTD	
	MS-V375	
	Size Custom	Document Description Input Power Balancing Switcher
Date: Monday, December 10, 2018		Sheet 37 of 53

PEX 3V3 INPUT - 10W

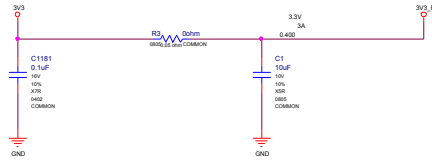

PEX_12V INPUT - 66W

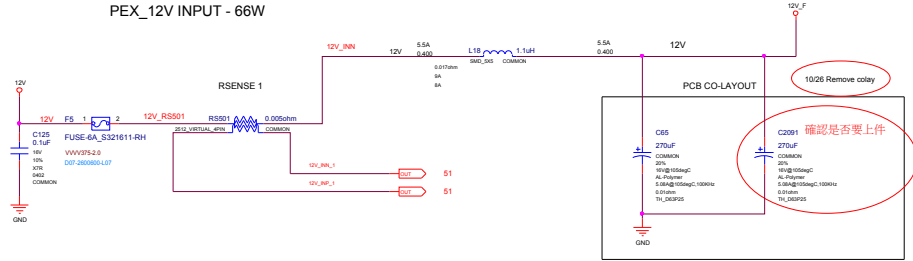

PEX8 INPUT 1 - 2x4 PCIE CON 150W

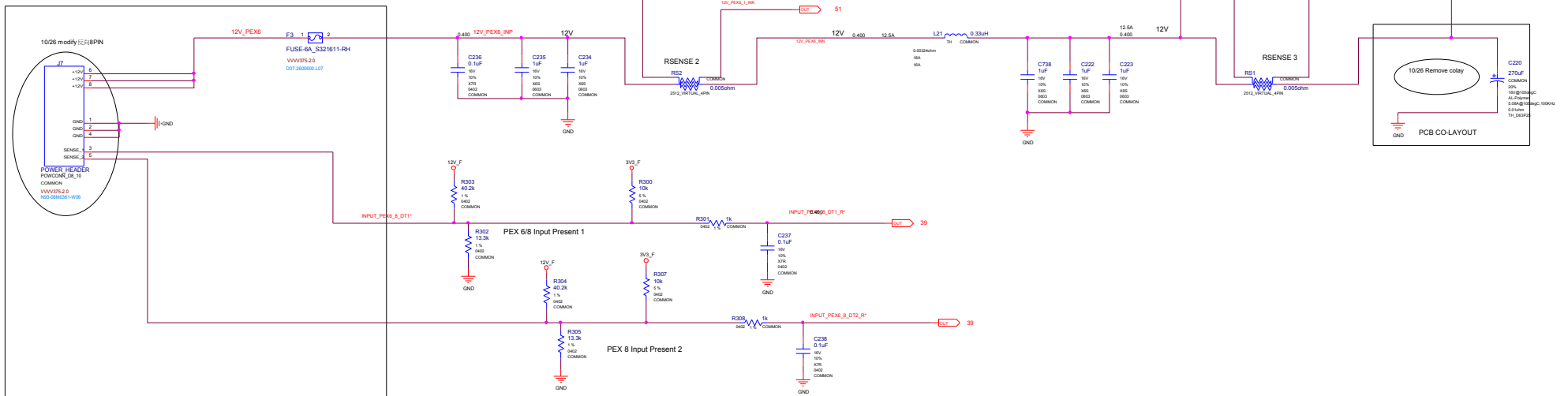

PEX Input Present 1

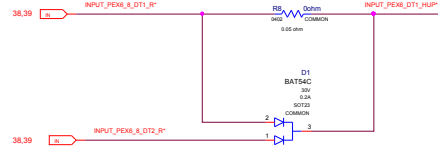

POWER CONNECTOR HOT-UNPLUG DETECT

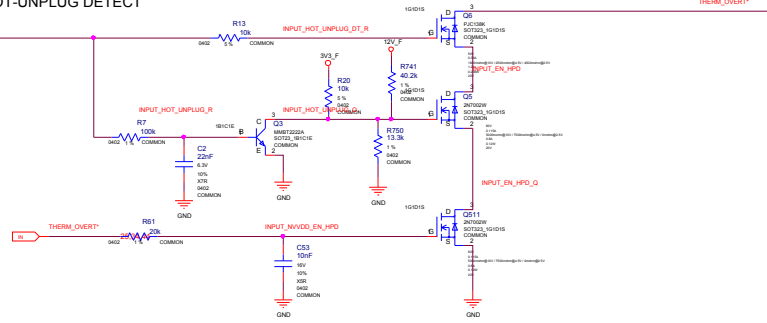

12V CURRENT STEERING (UNDER POWER BOOT):

GUIDES CURRENT FROM PEX EDGE TO PEX 6 PIN INPUT AREA

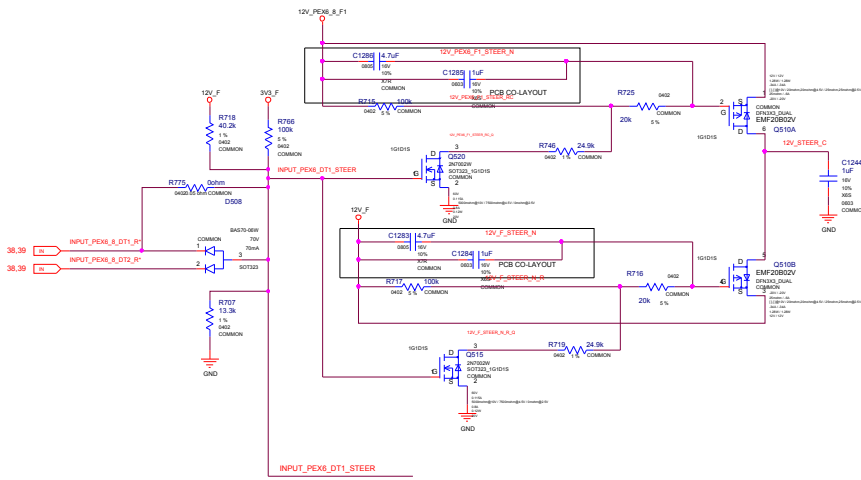

PEX Input - Power Level/PSI* Control

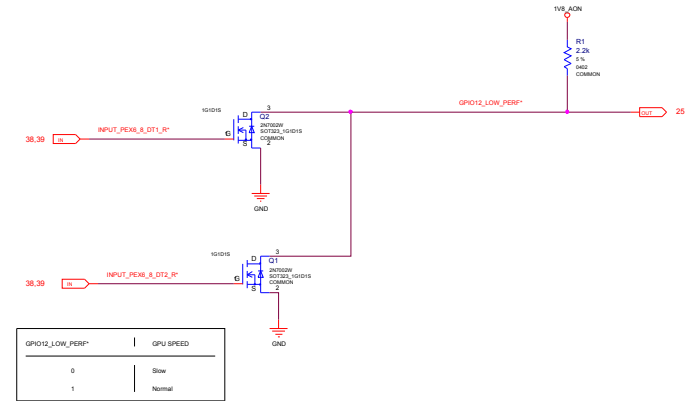

GPU12_LOW_PERF*	GPU SPEED
0	Slow
1	Normal

A B C D E F G H

1

1

2

2

3

3

4

4

5

5

	MICRO-STAR INT'L CO.,LTD	
	MS-V375	
	Size Custom	Document Description BUCKBOOST
Date: <u>Monday, December 10, 2018</u>		Sheet <u>40</u> of <u>53</u>

A B C D E F G H

1

1

2

2

3

3

4

4

5

5

	MICRO-STAR INT'L CO.,LTD	
	MS-V375	
	Size Custom	Document Description PPC
Date: Monday, December 10, 2018		Sheet 41 of 53

1
2
3
4
5

1
2
3
4
5

	MICRO-STAR INT'L CO.,LTD	
	MS-V375	
	Size Custom	Document Description 12V & 3V3_A SWITCHER
Date: Monday, December 10, 2018		Sheet 42 of 53

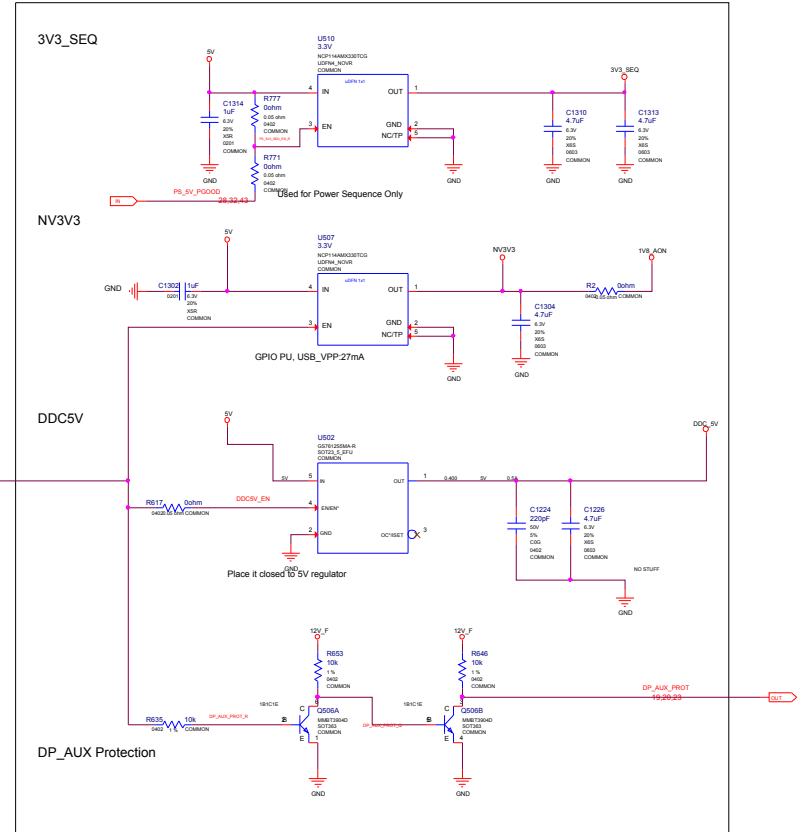
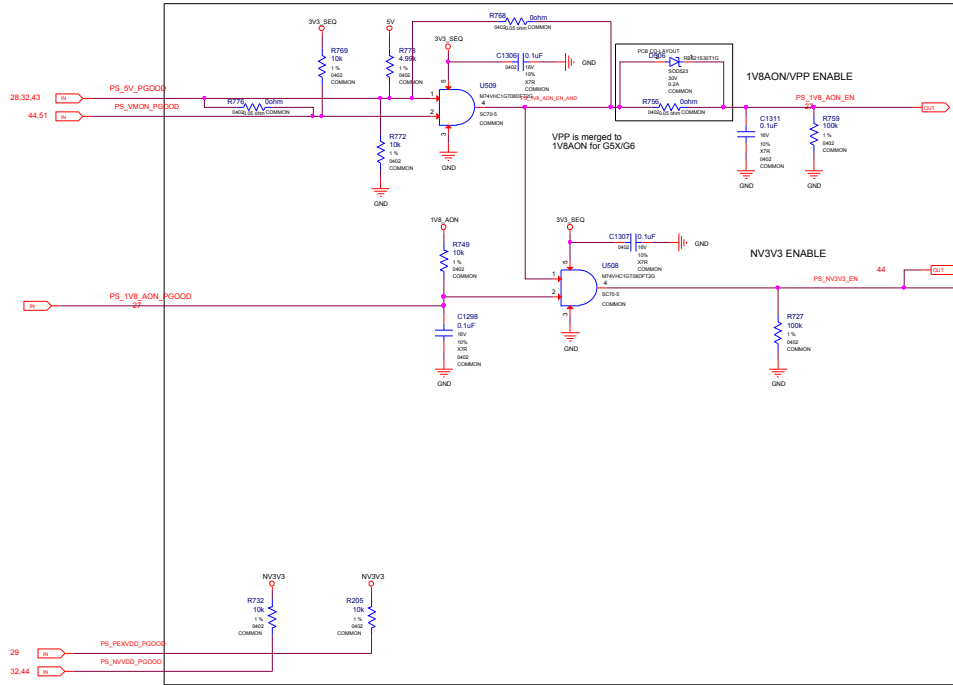

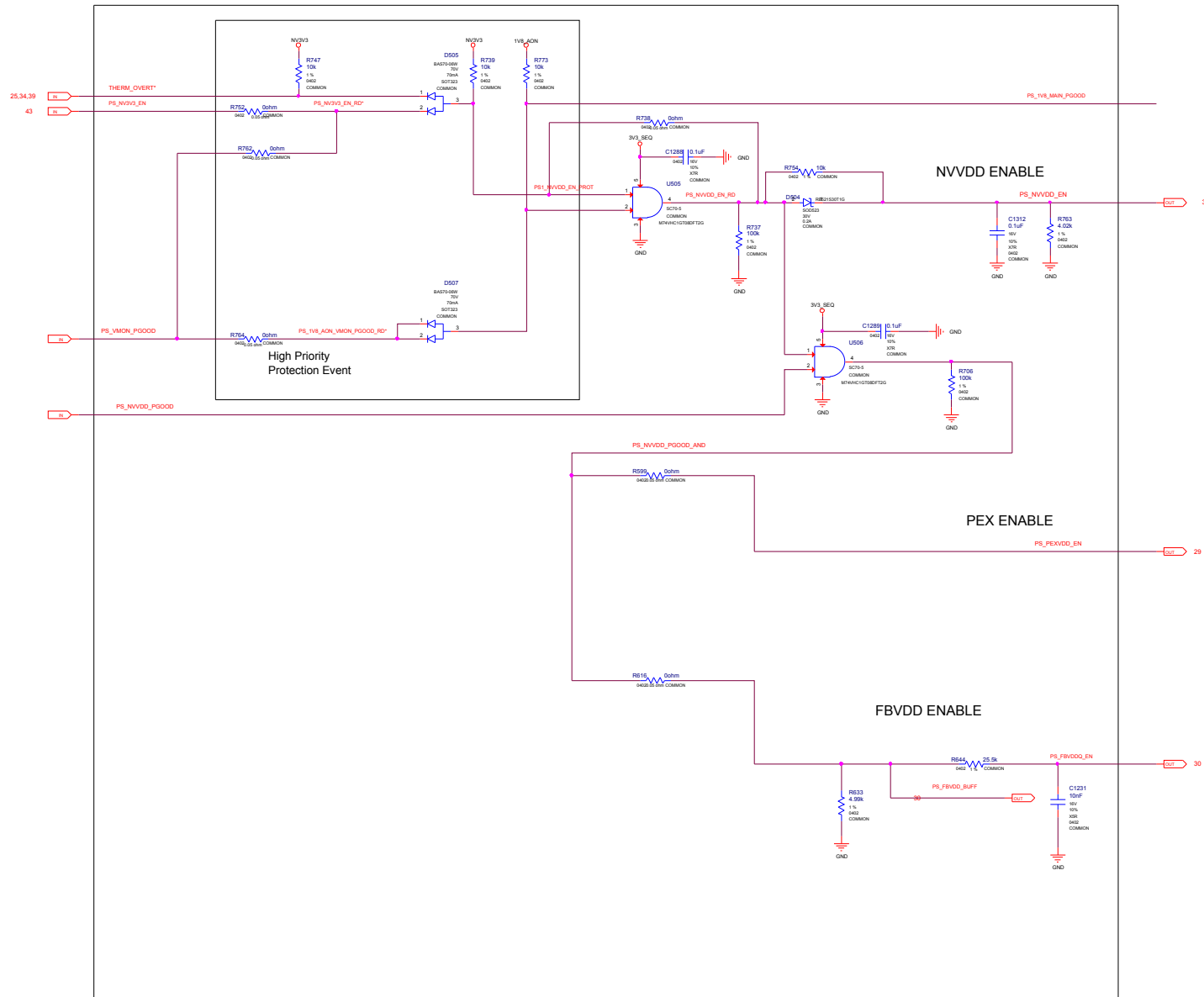

1

1

2

2

3

3

4

4

5

5

	MICRO-STAR INT'L CO.,LTD	
	MS-V375	
	Size Custom	Document Description SEQUENCE:Voltage Monitor
Date: <u>Monday, December 10, 2018</u>		Sheet <u>45</u> of <u>53</u>

	MICRO-STAR INT'L CO.,LTD	
	MS-V375	
	Size Custom	Document Description SEQUENCE:Discharge
Date: Monday, December 10, 2018		Sheet 46 of 53

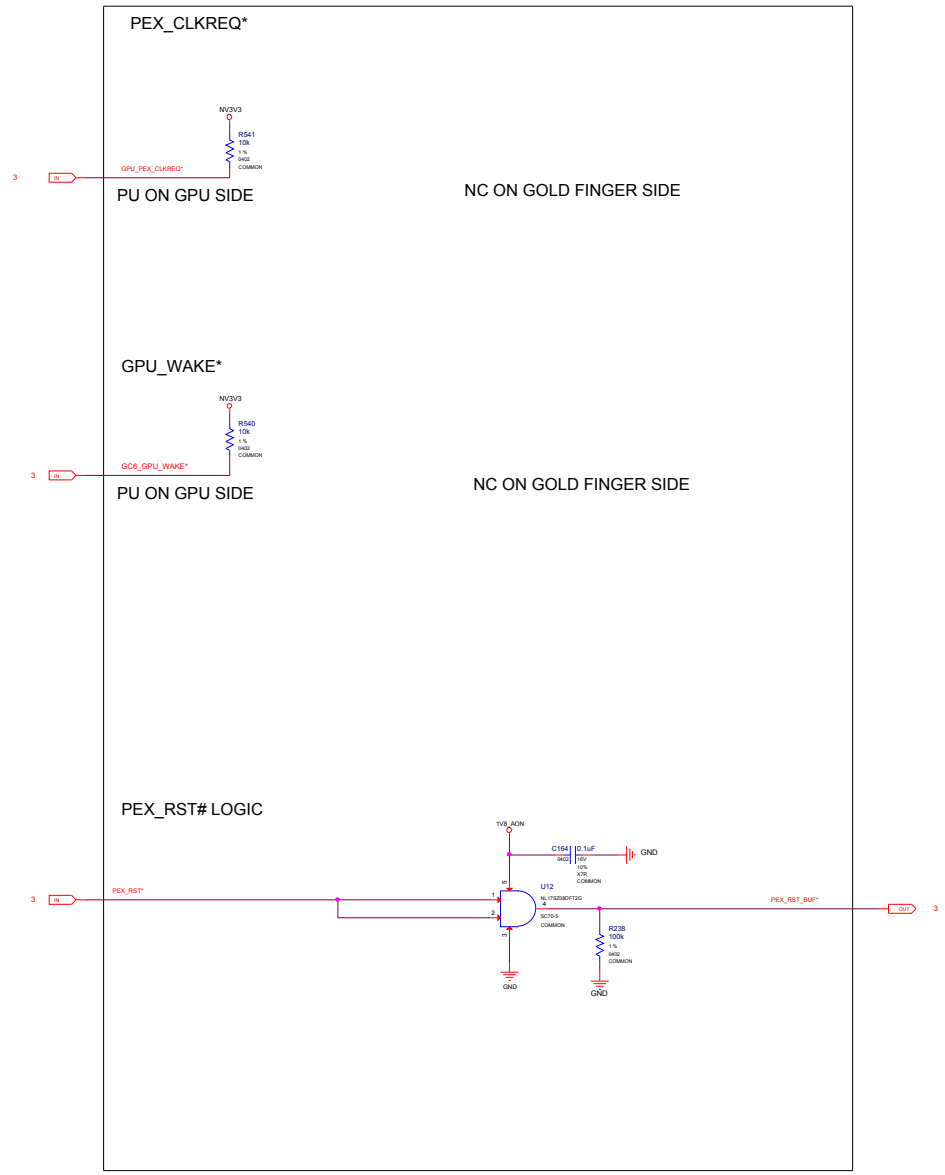

A B C D E F G H

1

1

2

2

3

3

4

4

5

5

A B C D E F G H

	MICRO-STAR INT'L CO.,LTD	
	MS-V375	
	Size Custom	Document Description LOGO LED
Date: <u>Monday, December 10, 2018</u>		Sheet <u>48</u> of <u>53</u>

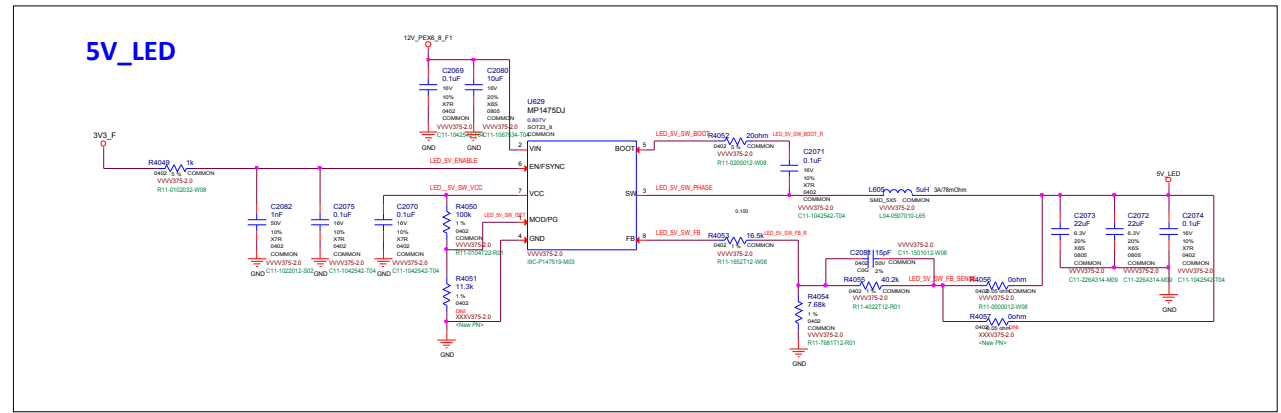
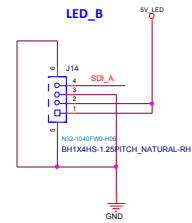
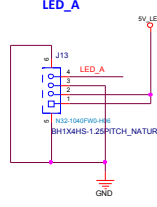
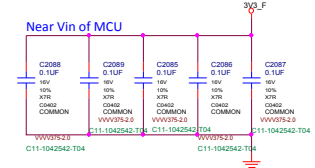
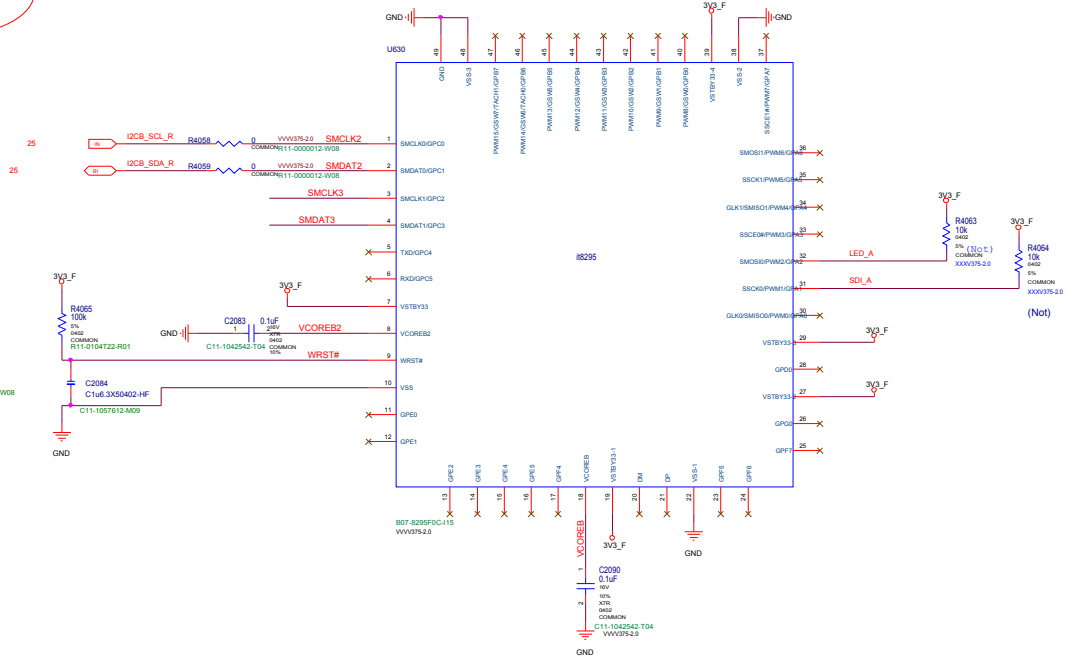
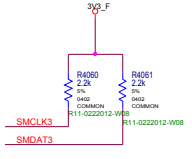
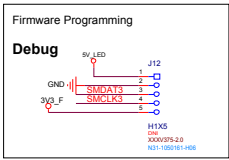

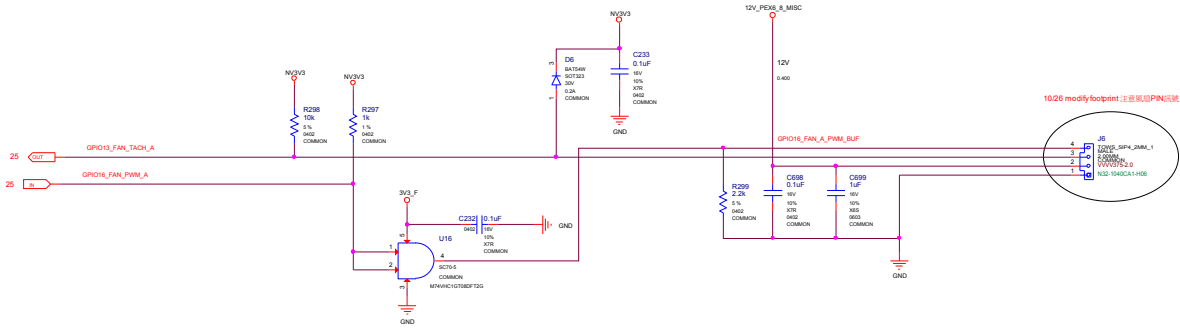

		MICRO-STAR INT'L CO.,LTD	
		MS-V375	
Size	Document Description	Rev	
Custom	FAN	2.0	
Date: Monday, December 10, 2018		Sheet	50 of 53

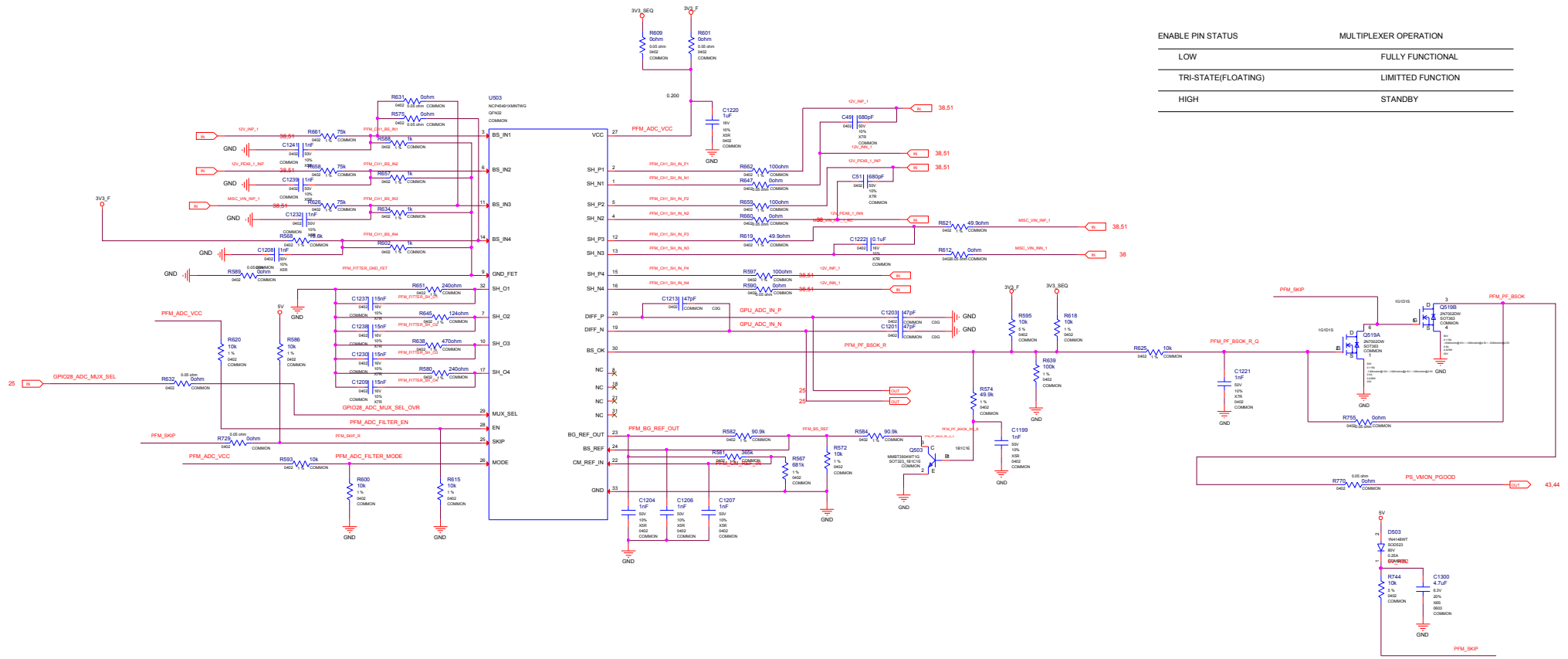

MODE PIN STATUS	MULTIPLEXER OPERATION
LOW	DEVICE A
TRI-STATE(FLOATING)	STAND-ALONE
HIGH	DEVICE B

ENABLE PIN STATUS	MULTIPLEXER OPERATION
LOW	FULLY FUNCTIONAL
TRI-STATE(FLOATING)	LIMITED FUNCTION
HIGH	STANDBY

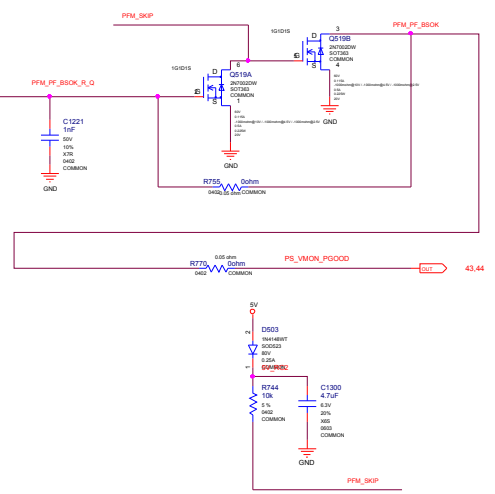

Bracket:

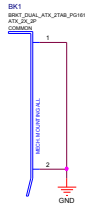

MOUNTING HOLES FOR HS:

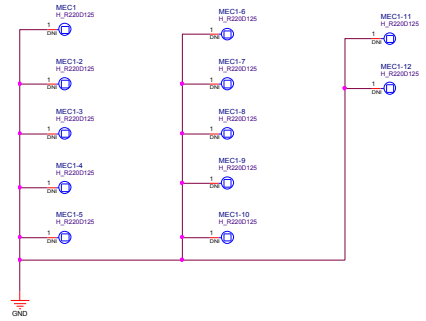

BACK STIFFENER:

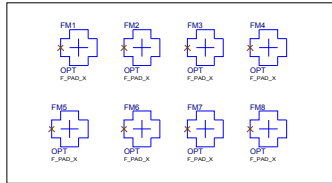
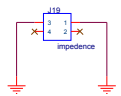
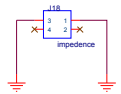

	MICRO-STAR INT'L CO.,LTD	
	MS-V375	
	Size	Document Description
	Custom	PTC
Date: Monday, December 10, 2018		Rev
Sheet 53 of 53		2.0