

N18P GDDR5 X32 128BITS
PCIE AND MODULAR DISPLAY

TABLE OF CONTENTS

Page	Description
1	TABLE OF CONTENTS
2	BLOCK DIAGRAM
3	PCI EXPRESS
4	MXM Connector
5	MEMORY: GPU PARTITION A/B
6	MEMORY: FBA[31:0]
7	MEMORY: FBA[63:32]
8	MEMORY_ FBB[31_0]
9	MEMORY_ FBB[63_32]
10	GPU PWR. GND and NCs
11	GPU DECOUPLING
12	GPU IFPAB DPIIM
13	GPU IFPCD DPIIM
14	GPU IFPE MICTOR
15	GPU_ ROM, STRAPS
16	GPU_ ROM, STRAPS
17	GPU_ XTAL, PLL
18	PS_ 1V8_AON
19	PS_ PEXVDD
20	PS_ NV3V3
21	PS_ FBVDD CONTROLLER
22	PS_ NVVDD CONTROLLER
23	PS_ NVVDD 2 PHASE
24	GPIO Functional Description
25	INPUT PREFILTER

Page	Description
26	DP_AUX Protection
27	Sequence
28	SEQUENCE_ DISCHARGE
29	MECH

	MICRO-STAR INT'L CO.,LTD	
	MS-V378	
Size	Document Description	Rev
Custom	BLOCK DIAGRAM	1.2
Date: Thursday, November 07, 2019		Sheet 2 of 29

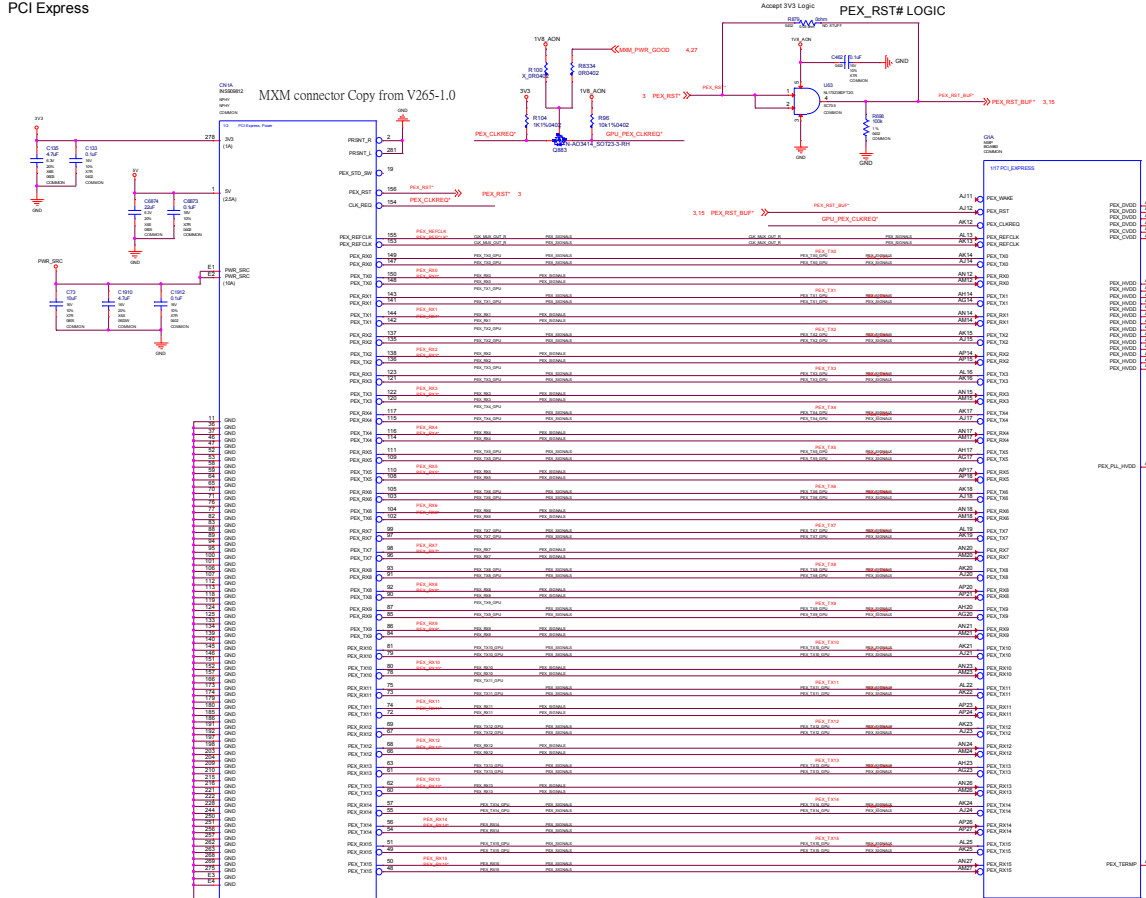

PEX_DVDD	1uF X6S	4.7uF X6S	10uF X6S	22uF X6R
N18P	6	3	3	2

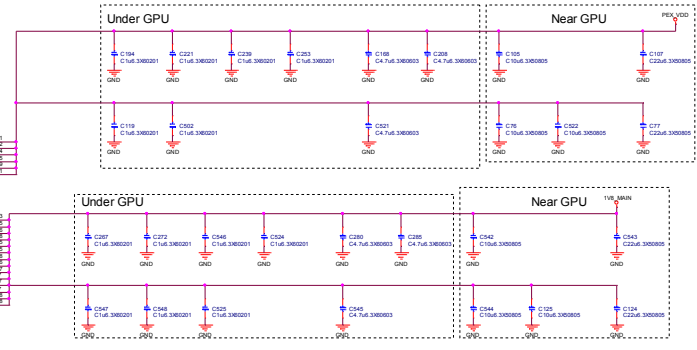

PEX_PLL_HVDD	0.1uF X7R	1uF X6S
N17P & N18M-Q3	1	0
N18P	0	1

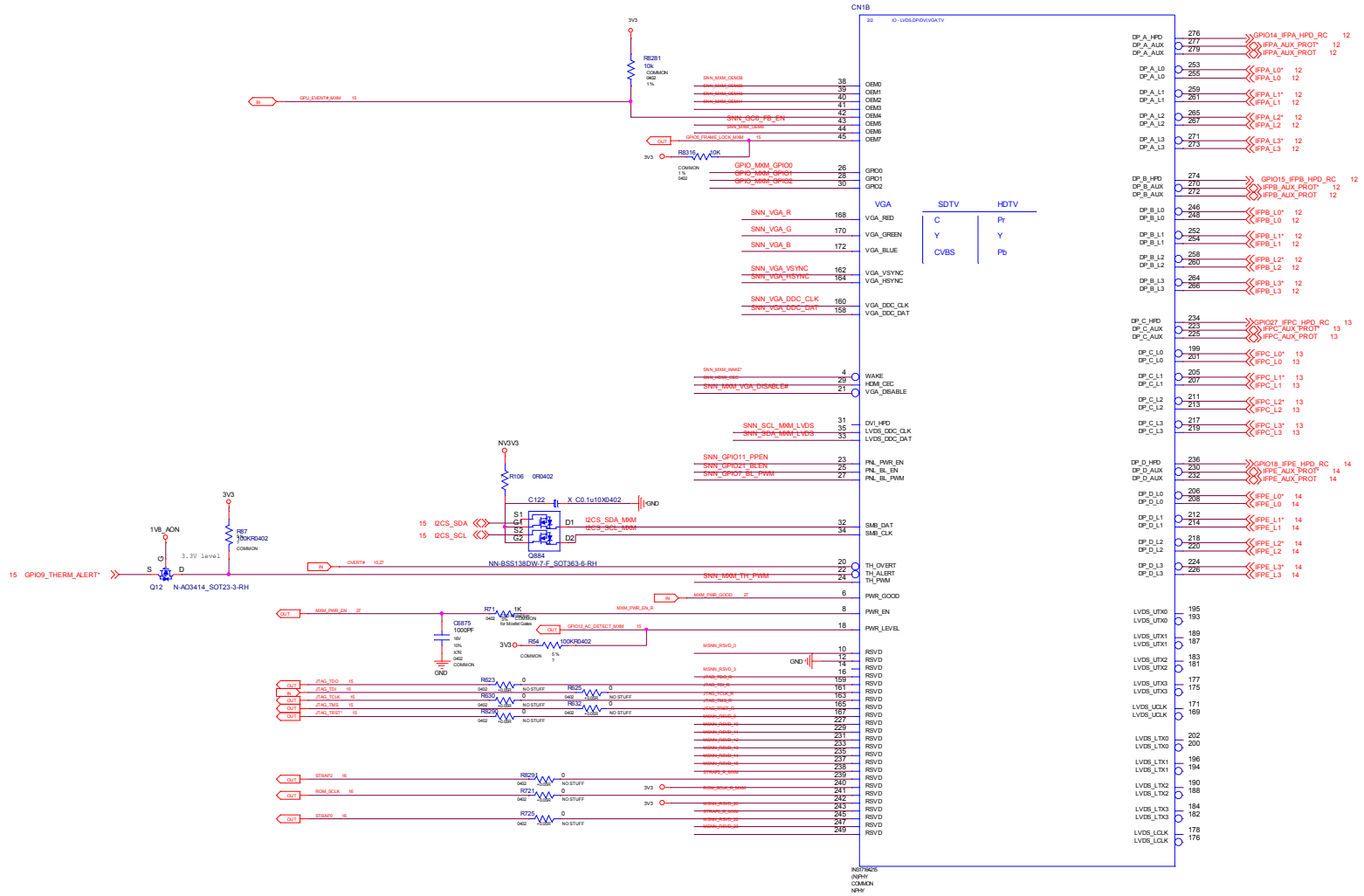

MEMORY: GPU PARTITION A/B

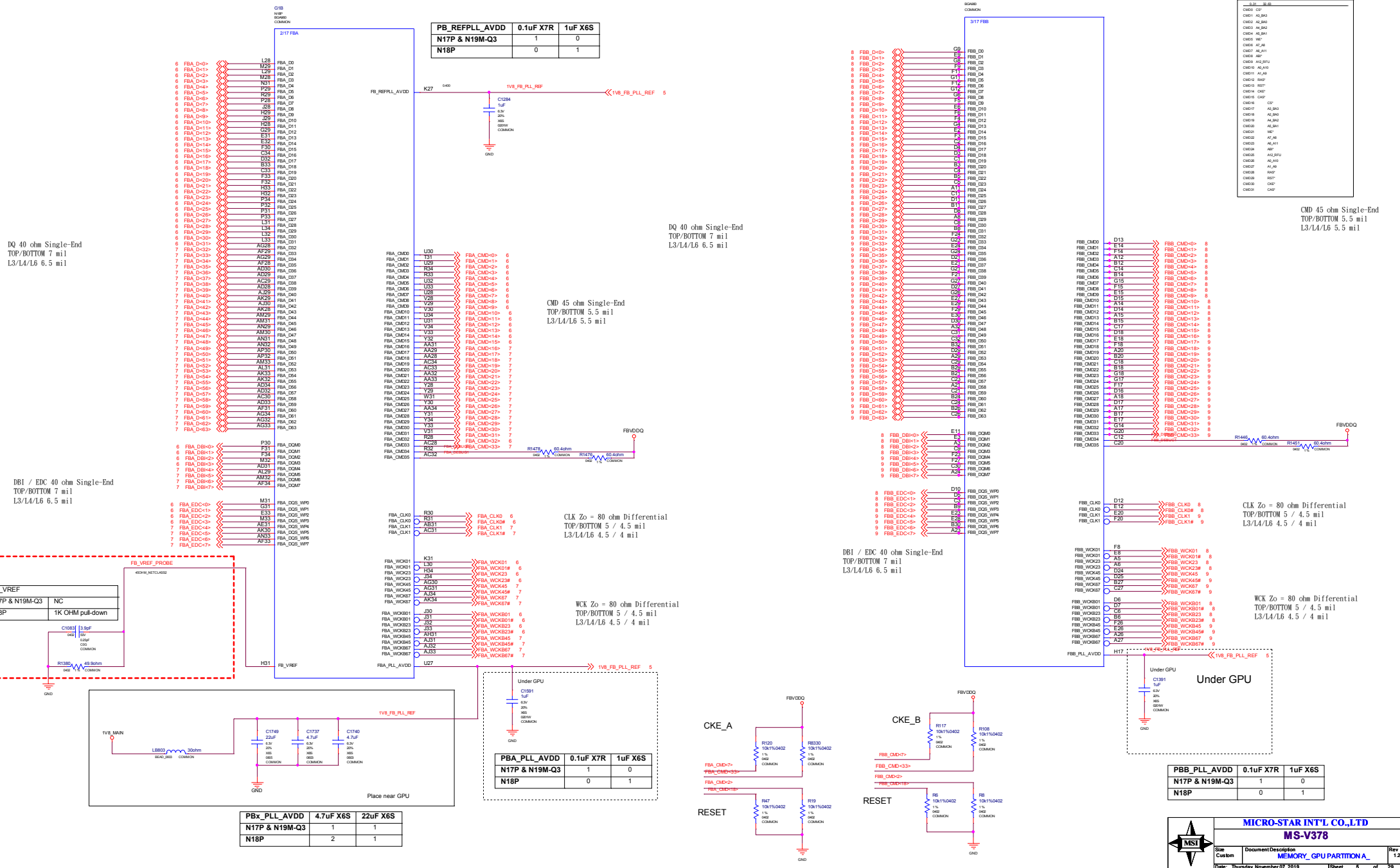

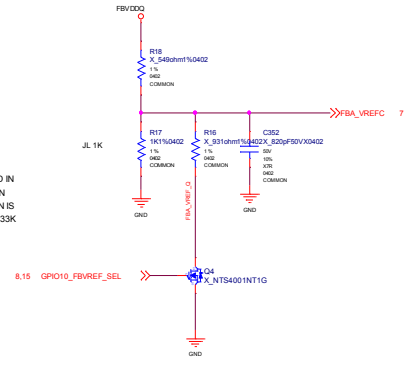
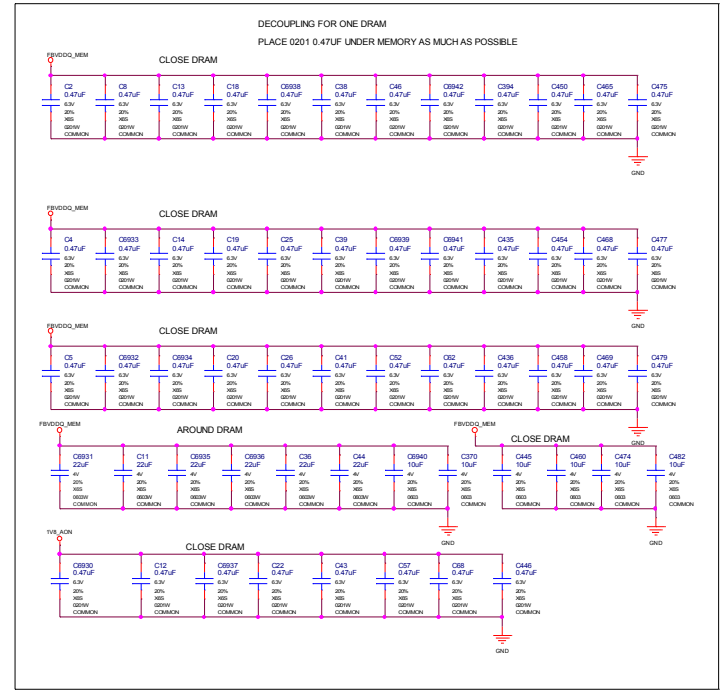
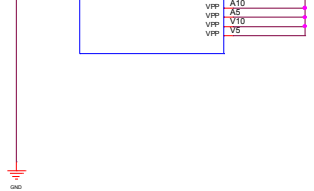
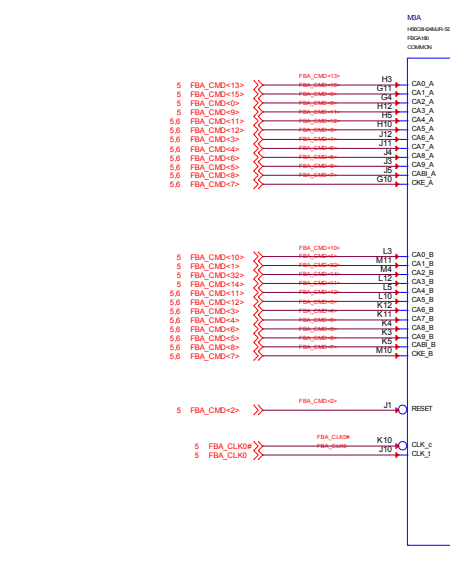
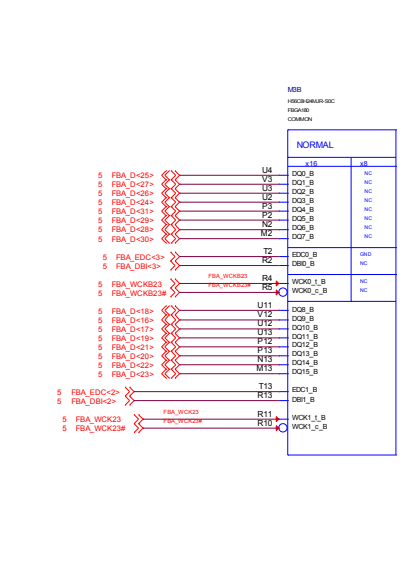
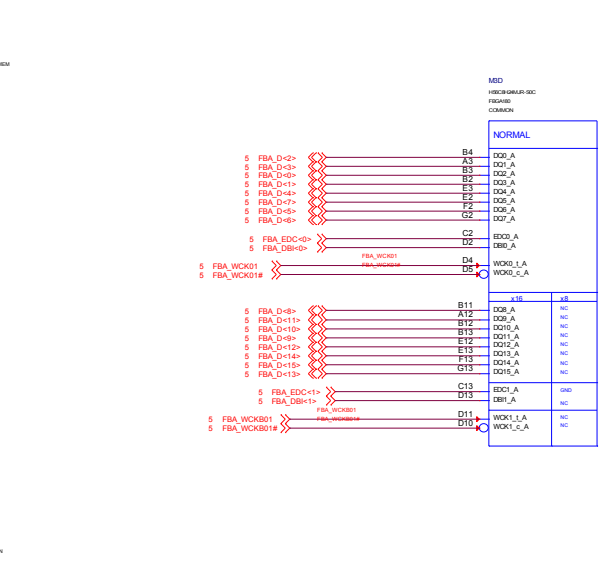
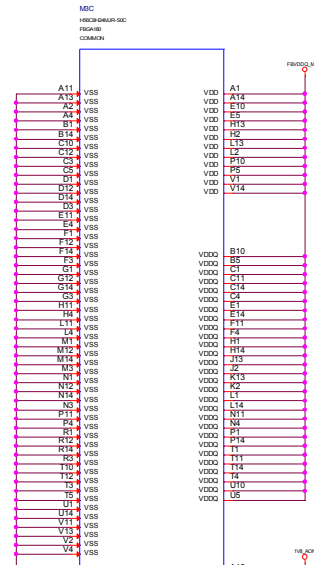

VREFC IS NOT USED IN x16 CONFIGURATION IN PLACE OF THE 1.33K FOR R104

B.15 GPIO10_VREF_SEL

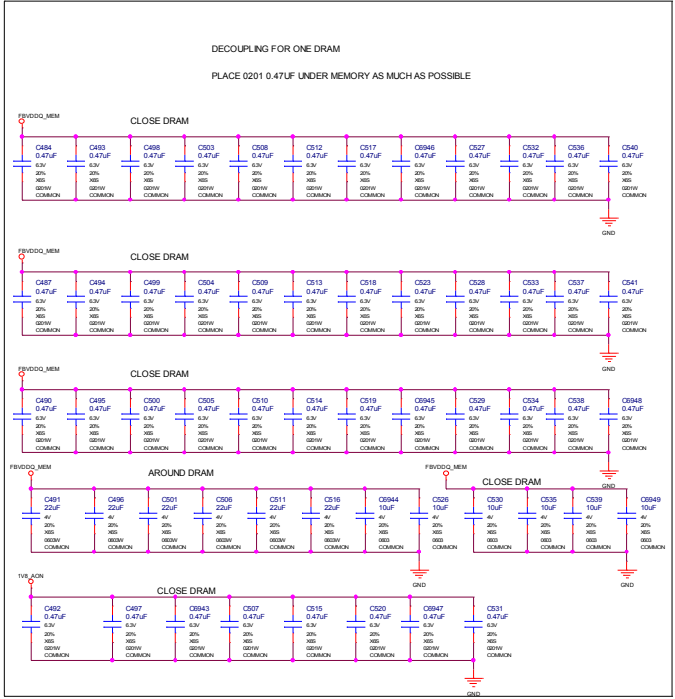
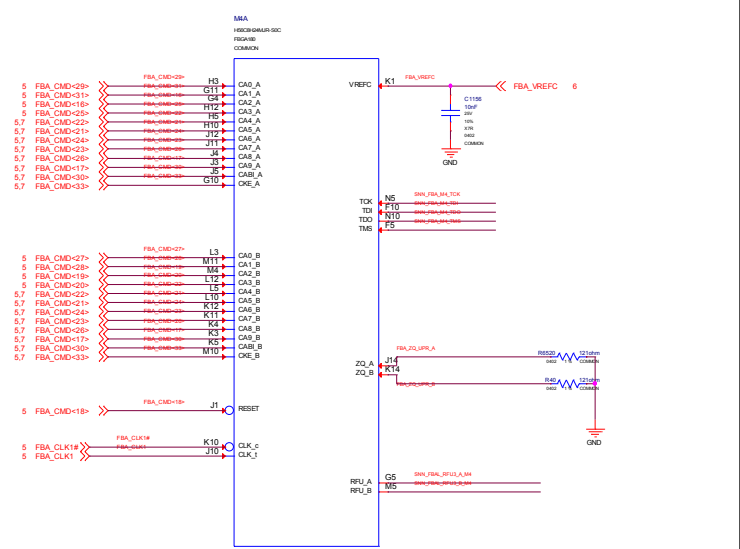
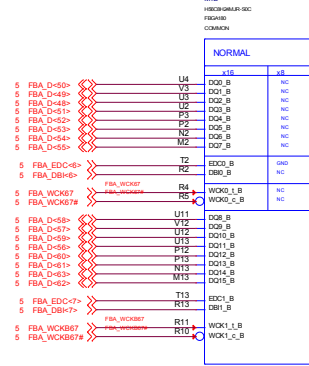
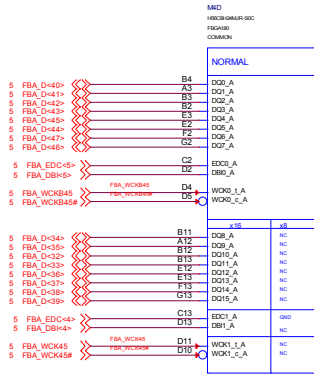
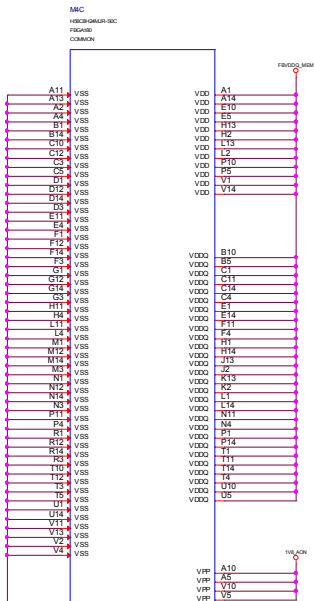

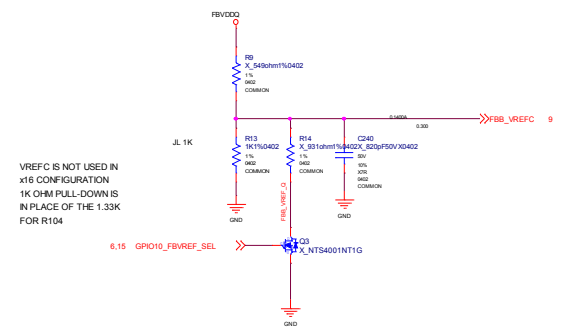
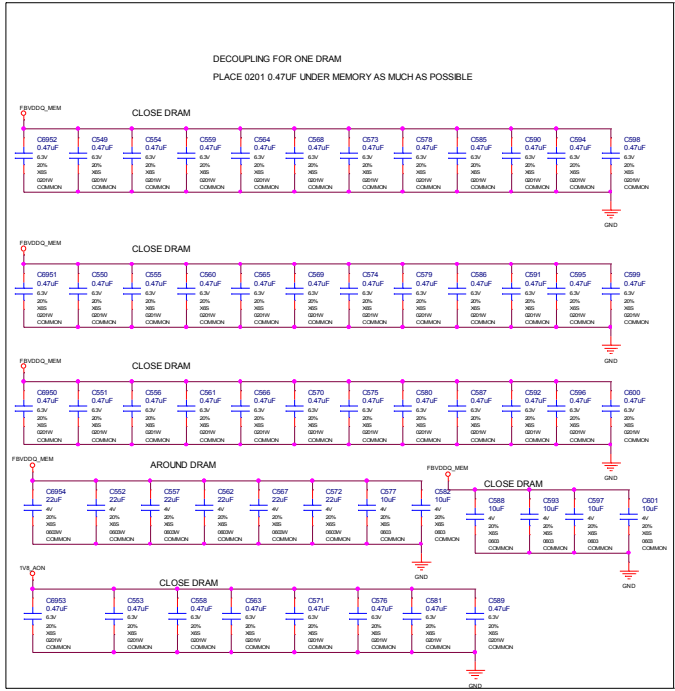
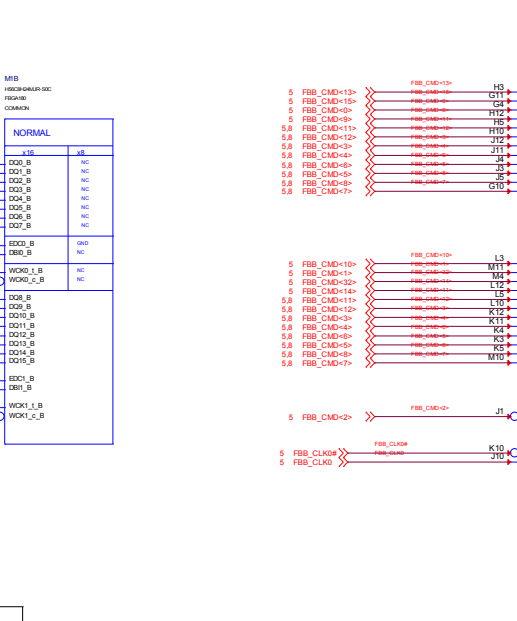
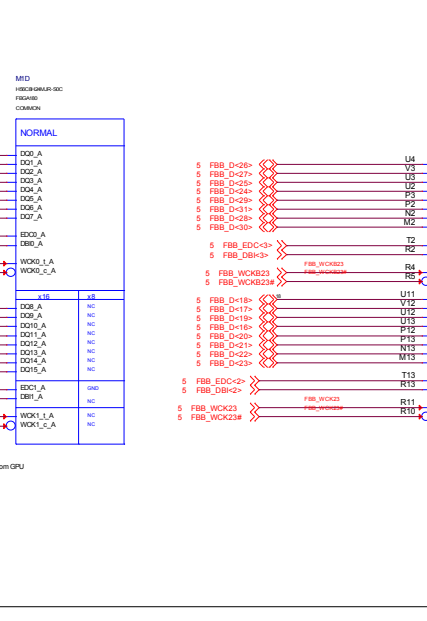
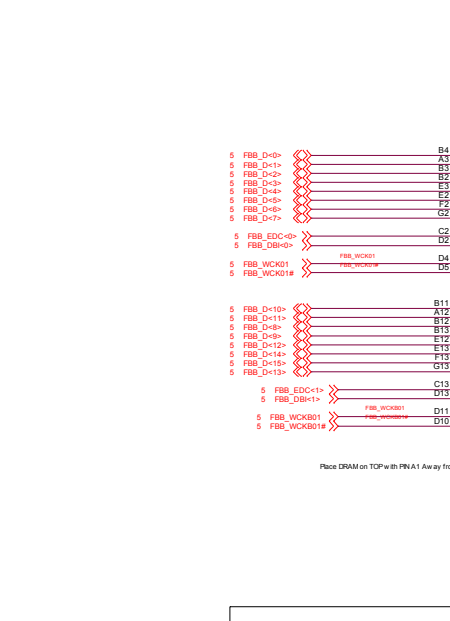
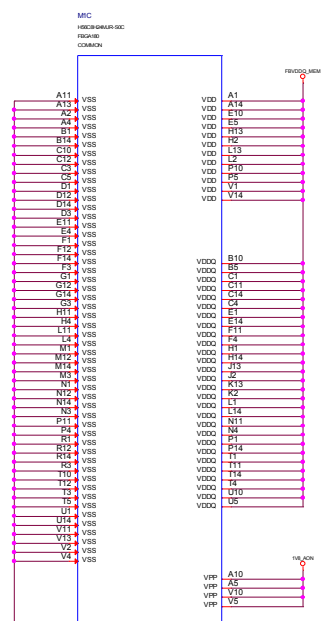

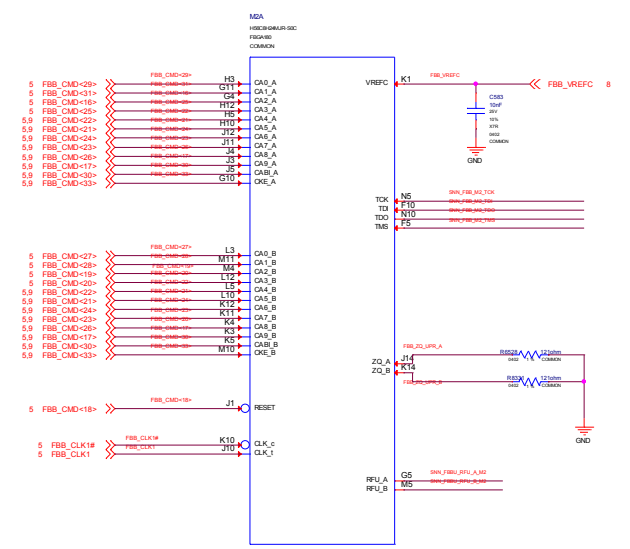
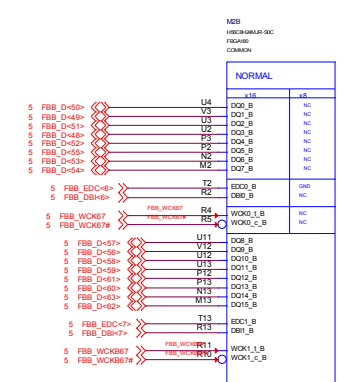
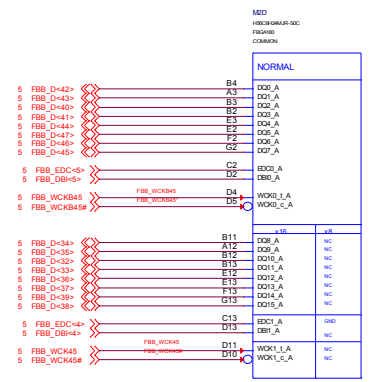
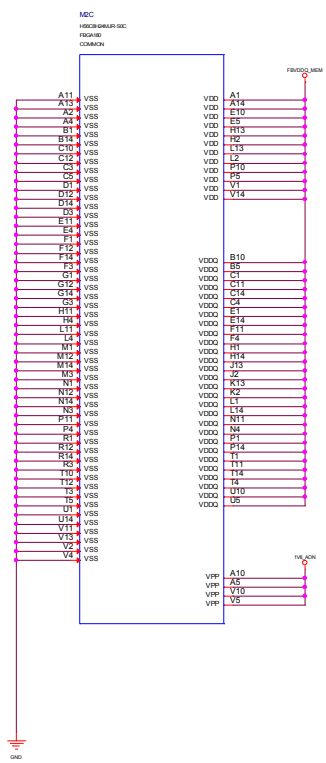

Place DRAM on TOP with FN#1 Toward GPU

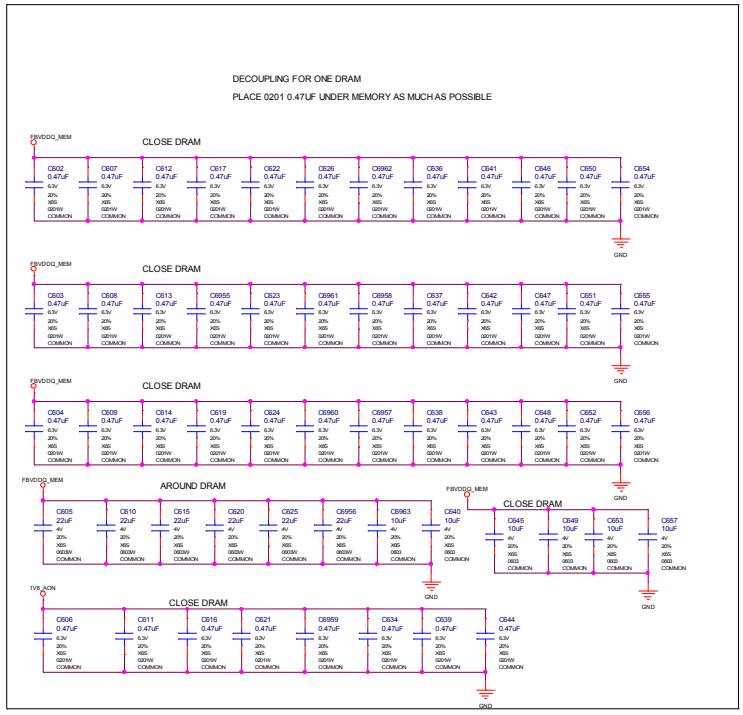

GPU DECOUPLING

NVDD

NVDD

Place under to GPU

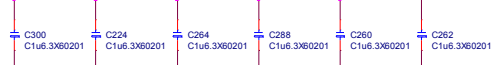

Place under to GPU



Place under to GPU

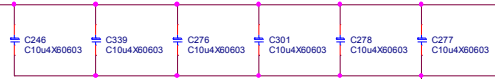

Place under to GPU

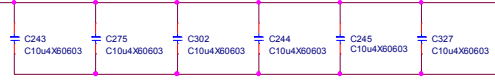

Place under to GPU



Place under to GPU



Place near to GPU



Place near to GPU



Place near to GPU



NVDD	1uF X6S	10uF X6S	22uF X6S
	0201	0603	0805
N19P-Q3/Q1	13	34	15

FBVDDQ

FBVDDQ

Place under to GPU



Place under to GPU



Place under to GPU



FBVDDQ	1uF X6S	10uF X6S	22uF X6S	10uF X6S
	0201	0603	0603	0603
N19P-Q3/Q1	12	4	5	2

Place near to GPU



MICRO-STAR INT'L CO.,LTD
MS-V378

Size	Document Description	Rev
Custom	GPU DECOUPLING	1.2
Date:	Thursday, November 07, 2019	Sheet 11 of 29

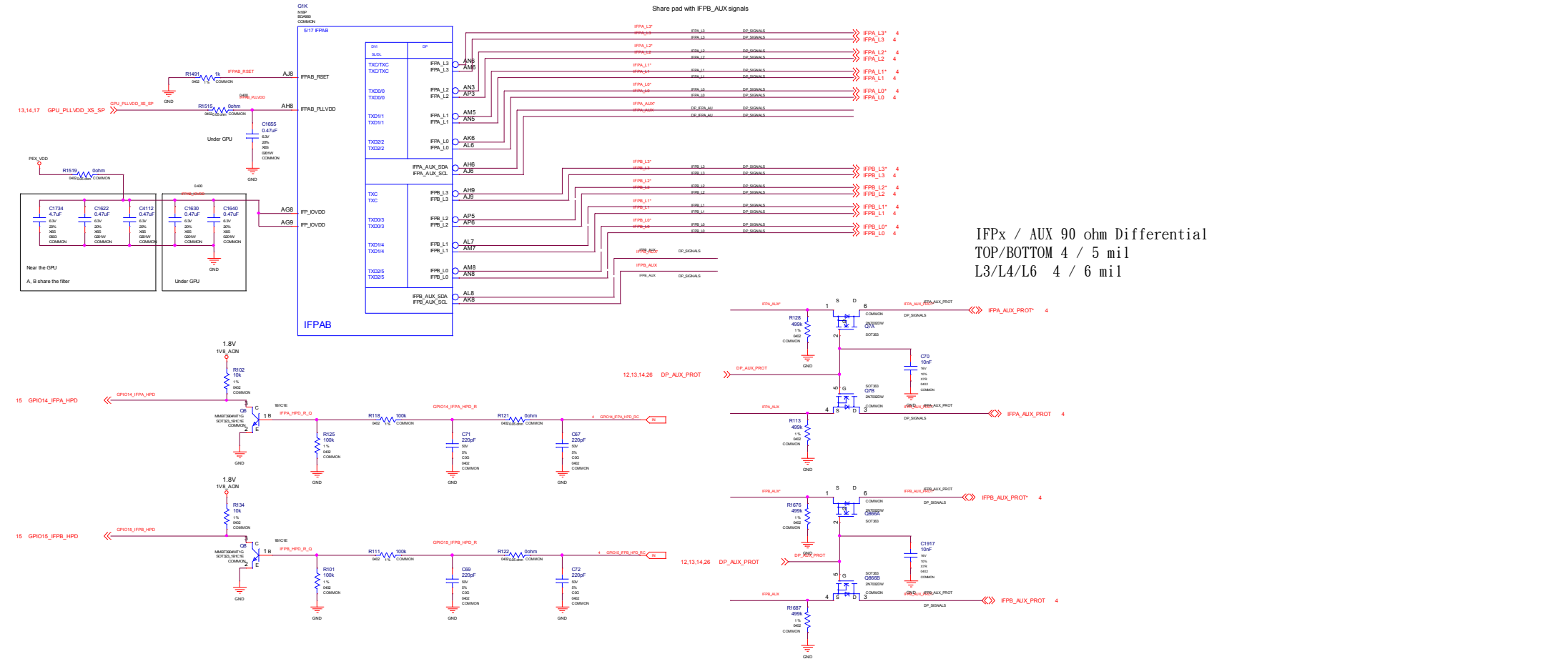

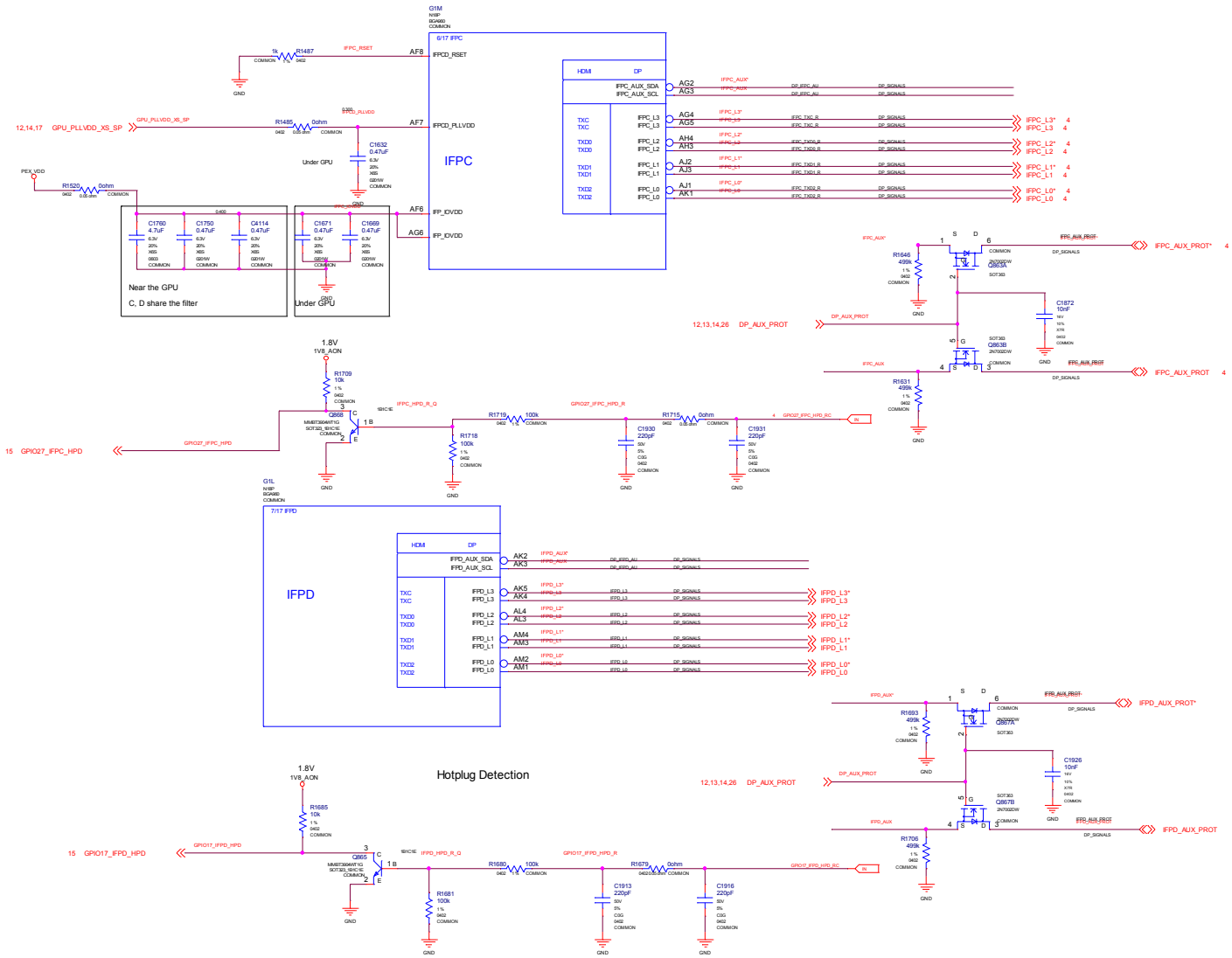

IFPE MICTOR

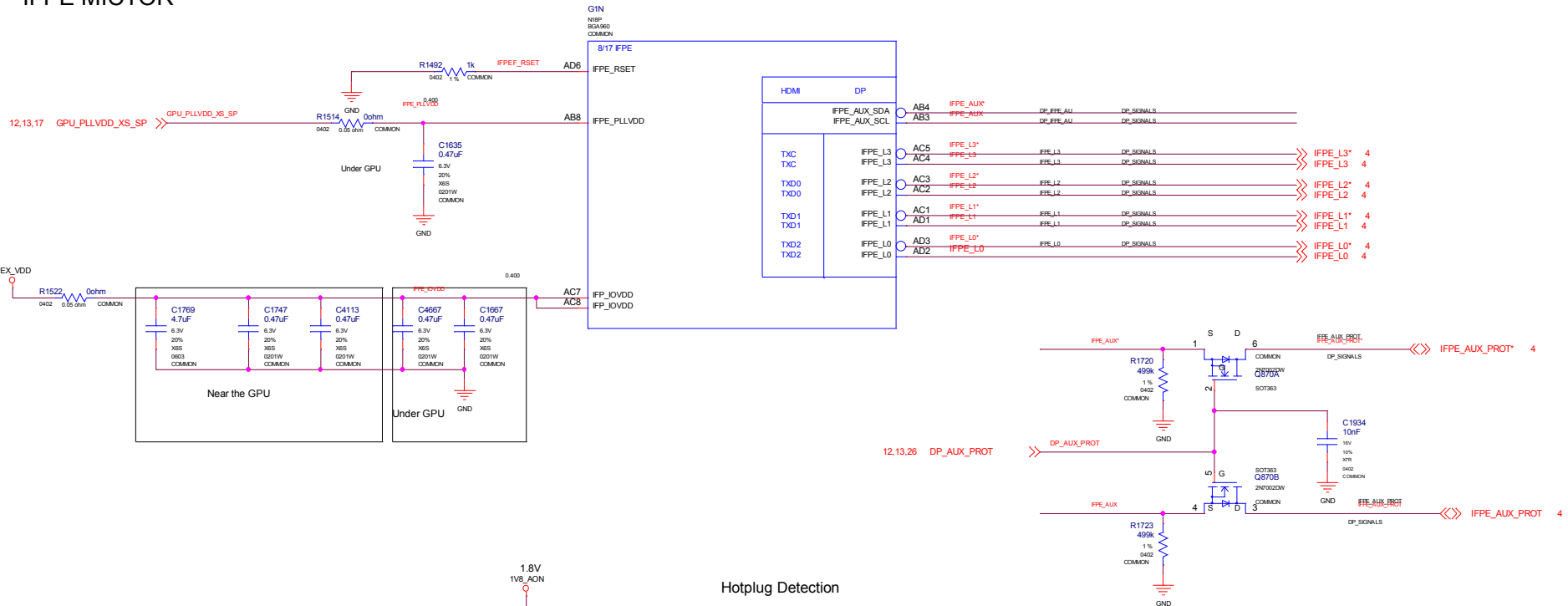

Hotplug Detection

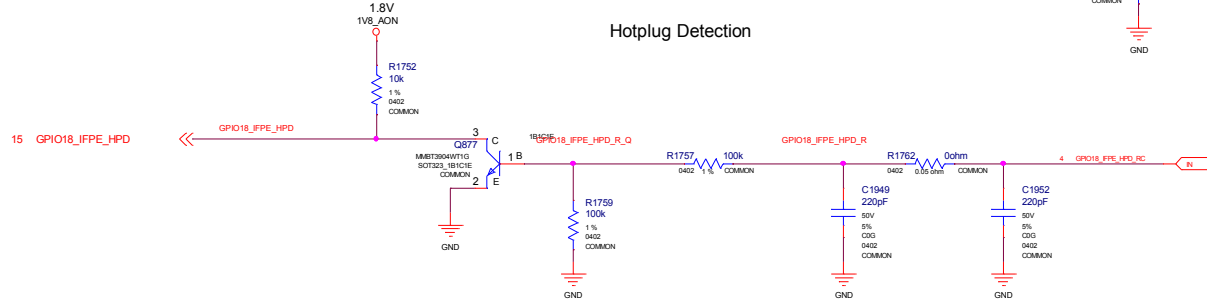

MICRO-STAR INT'L CO.,LTD

MS-V378

Size	Document Description	Rev
Custom	GPU IFPE MICTOR	1.2
Date:	Thursday, November 07, 2019	Sheet 14 of 29

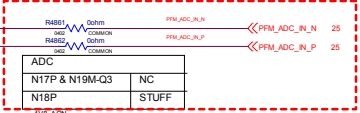
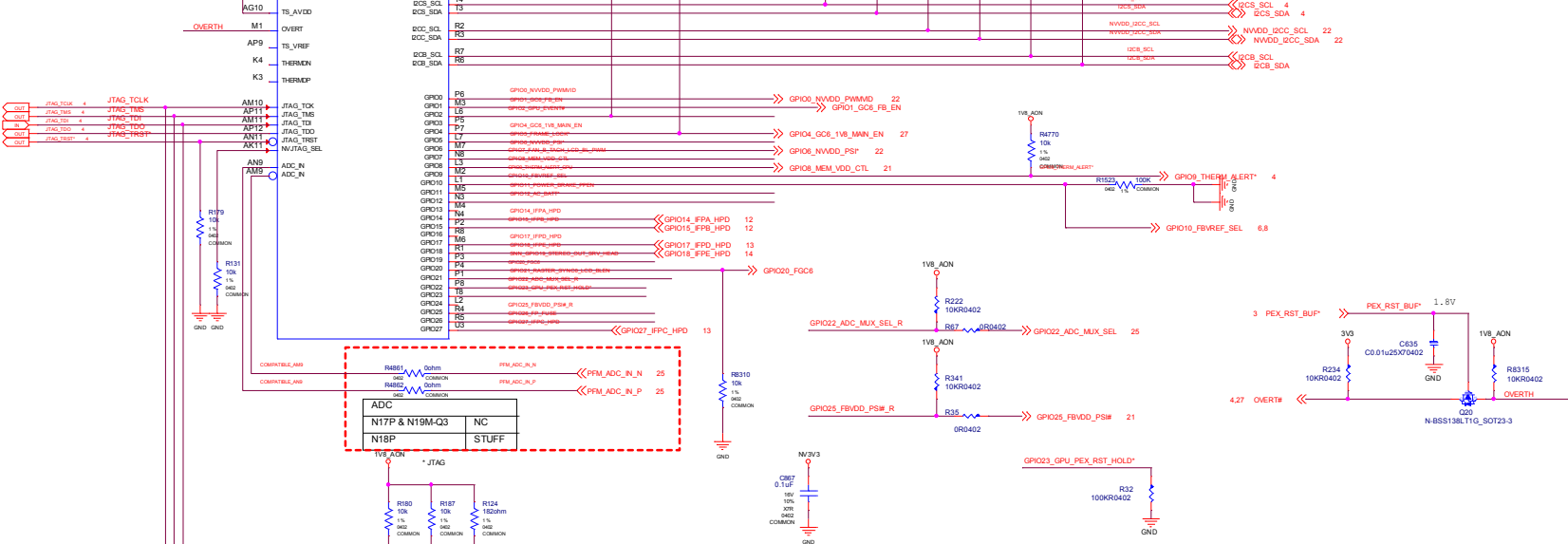
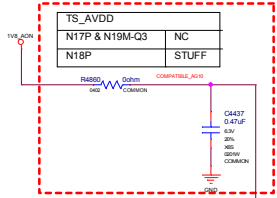
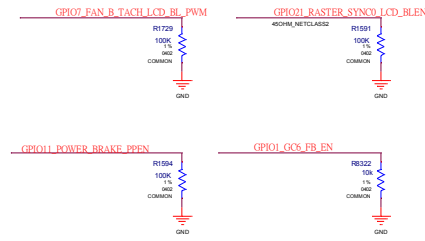
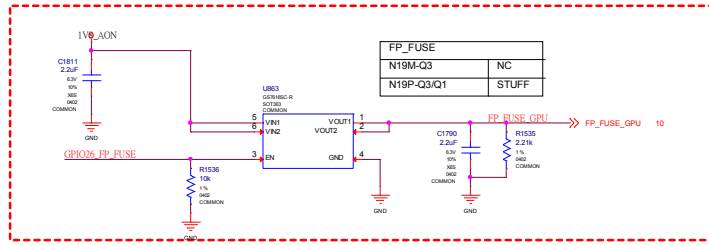

ADC	
N17P & N19M-Q3	NC
N18P	STUFF

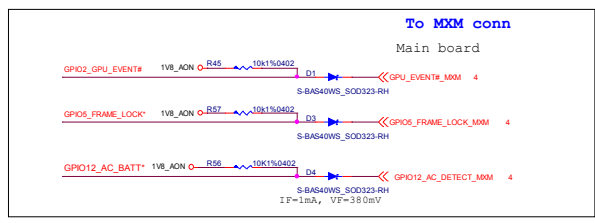

MISC2: ROM, Straps

STRAP2	STRAP1	STRAP0	RAMCFG[4:0]	
L	L	L	00000	RAMCFG TBD
L	H	L	00010	RAMCFG TBD
L	H	H	00011	RAMCFG TBD
H	H	L	00110	RAMCFG TBD
H	H	H	00111	RAMCFG TBD

H=High :Tied to 1.8V
M=Middle:Tied to 0.9V
L=Low :Tied to 0V

ROM_SO	ROM_SI	ROM_SCLK	DUMMY[2:0],FS_OVERT	1.ENABLE 0.DISABLE	DEFAULT
L	L	L	XXX1	FS_OVERT ENABLE	
L	L	M	XXX0	FS_OVERT DISABLE	

STRAP5	STRAP4	STRAP3	SMB_ALT_ADDR	DEVID_SEL	PCIE_CFG	VGA_DEVICE	DEFAULT
M	H	H	1	1	1	1	
M	H	L	1	1	1	0	
M	L	H	1	1	0	1	
M	L	L	1	1	0	0	
L	H	M	1	0	1	1	
L	M	H	1	0	1	0	
L	L	L	1	0	0	1	
L	L	M	1	0	0	0	
H	H	H	0	1	1	1	
H	H	L	0	1	1	0	
H	L	H	0	1	0	1	
H	L	L	0	1	0	0	
L	H	H	0	0	1	1	
L	H	L	0	0	1	0	
L	L	H	0	0	0	1	
L	L	L	0	0	0	0	

DEFAULT

- 1.SMB_ALT_ADDR ENABLE
- 0.SMB_ALT_ADDR DISABLE
- 1.DEVID_SEL REBRAND
- 0.DEVID_SEL ORIGINAL
- 1.PCI_CFG LOW POWER
- 0.PCI_CFG HIGH POWER
- 1.VGA_DEVICE ENABLE
- 0.VGA_DEVICE DISABLE

Default

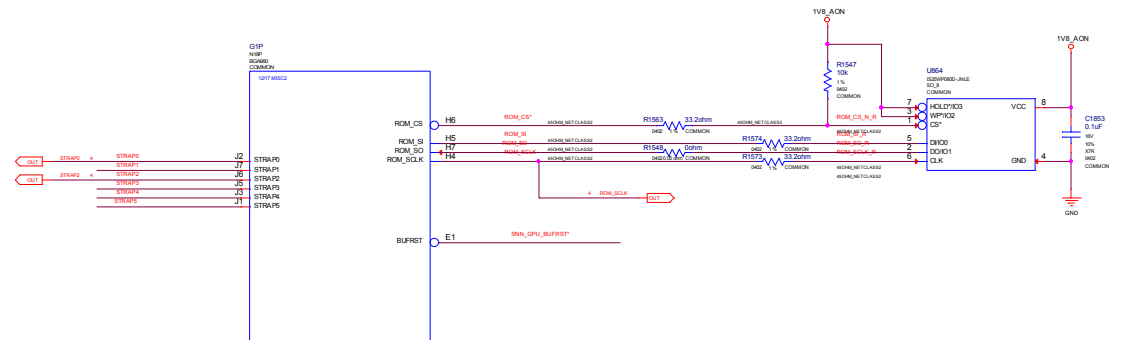
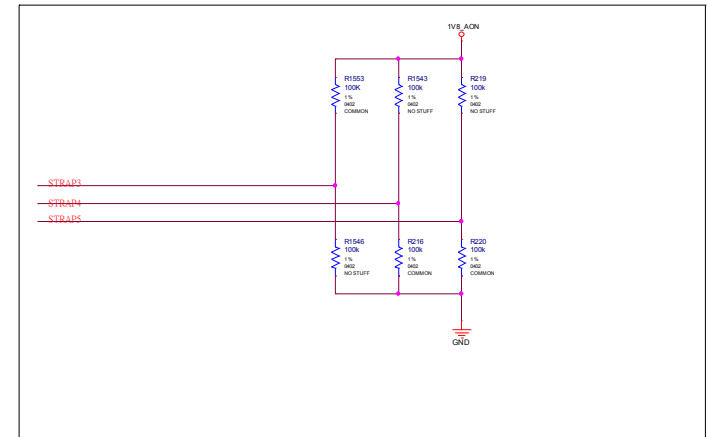
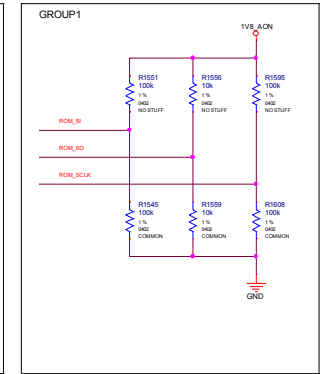
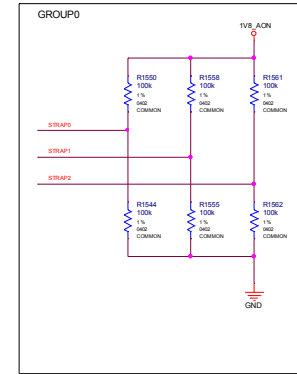

MISC2: XTAL. PLL

XSN_PLLVDD	0.1uF X7R	1uF X6S	4.7uF X6S	22uF X6S
GPCPLL_AVDD				
SP_PLLVDD				
VID_PLLVDD				
N17P & N19M-Q3	4	0	1	1
N18P	0	4	1	1

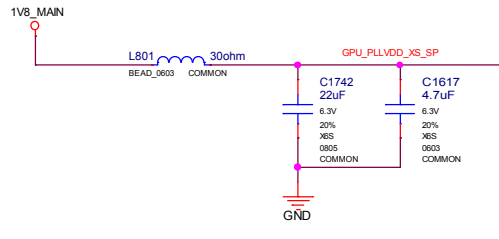

Place near GPU

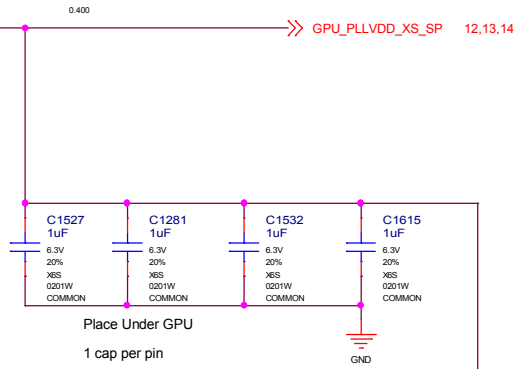

Place Under GPU
1 cap per pin

12.2.2.5 XTALOUTBUFF Circuit Node

For mobile graphics circuit designs (or other designs wherein the graphics circuit does not directly and fully control its own cooling fan), the XTALOUTBUFF circuit node must be tied to GND through 100KΩ resistors.

SmartFan Strap Table

Voltage	Inverted SmartFan PWM %
0V	GPIO DISABLED
0.9V	33% PWM
1.8V	66% PWM

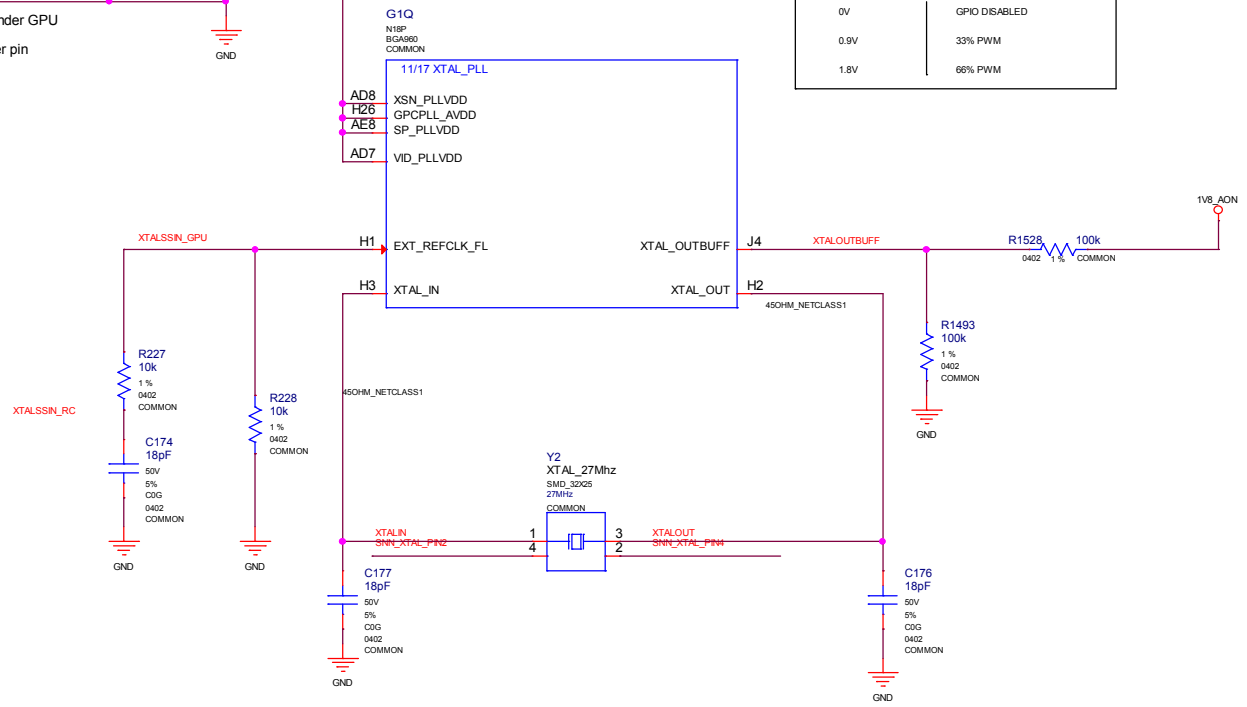

MICRO-STAR INT'L CO.,LTD
MS-V378

Size B	Document Description	GPU_XTAL_PLL	Rev 1.2
Date: Thursday, November 07, 2019	Sheet	17	of 29

PS: 1V8_AON

Voltage = 1.8V
 Current = ? A
 OCP(typi) = ? A

1V8_AON

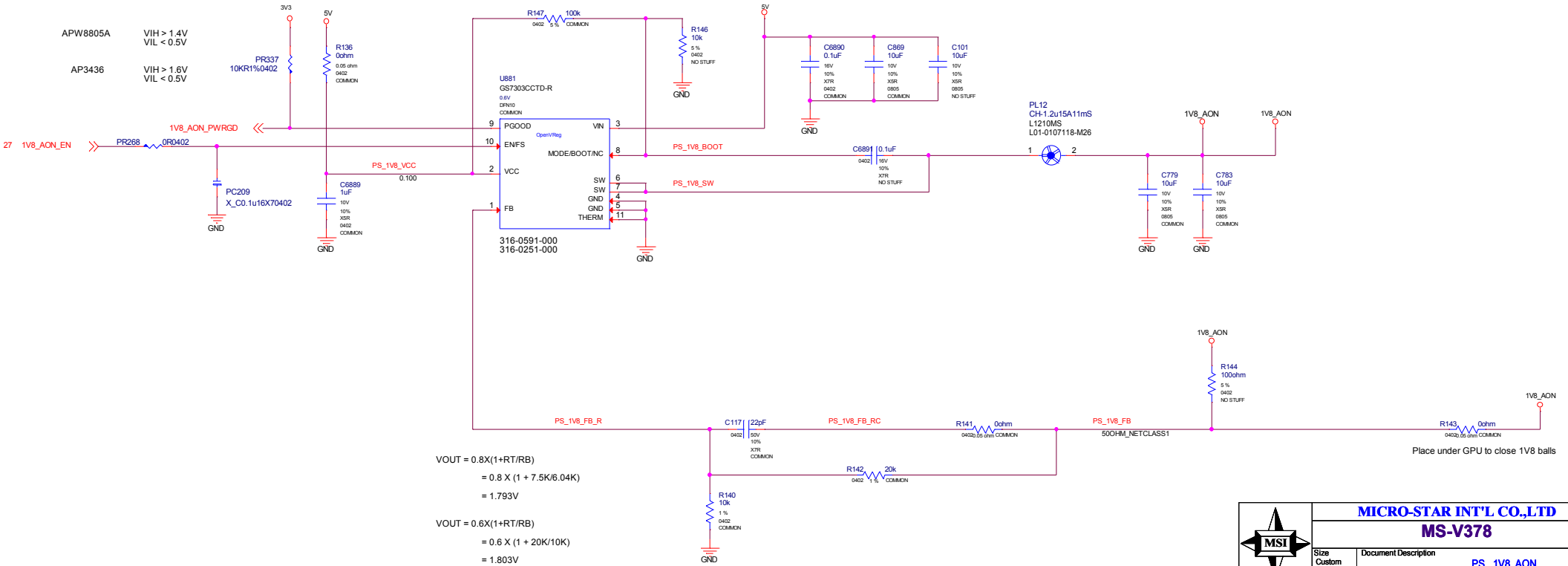

$$V_{OUT} = 0.8X(1+RT/RB)$$

$$= 0.8 X (1 + 7.5K/6.04K)$$

$$= 1.793V$$

$$V_{OUT} = 0.6X(1+RT/RB)$$

$$= 0.6 X (1 + 20K/10K)$$

$$= 1.803V$$

		
MICRO-STAR INT'L CO.,LTD		
MS-V378		
Size	Document Description	Rev
Custom	PS_1V8_AON	1.2
Date: Thursday, November 07, 2019		Sheet 18 of 29

PS_PEXVDD

Voltage = 1.0V
 Current = ? A
 OCP(typi) = ? A

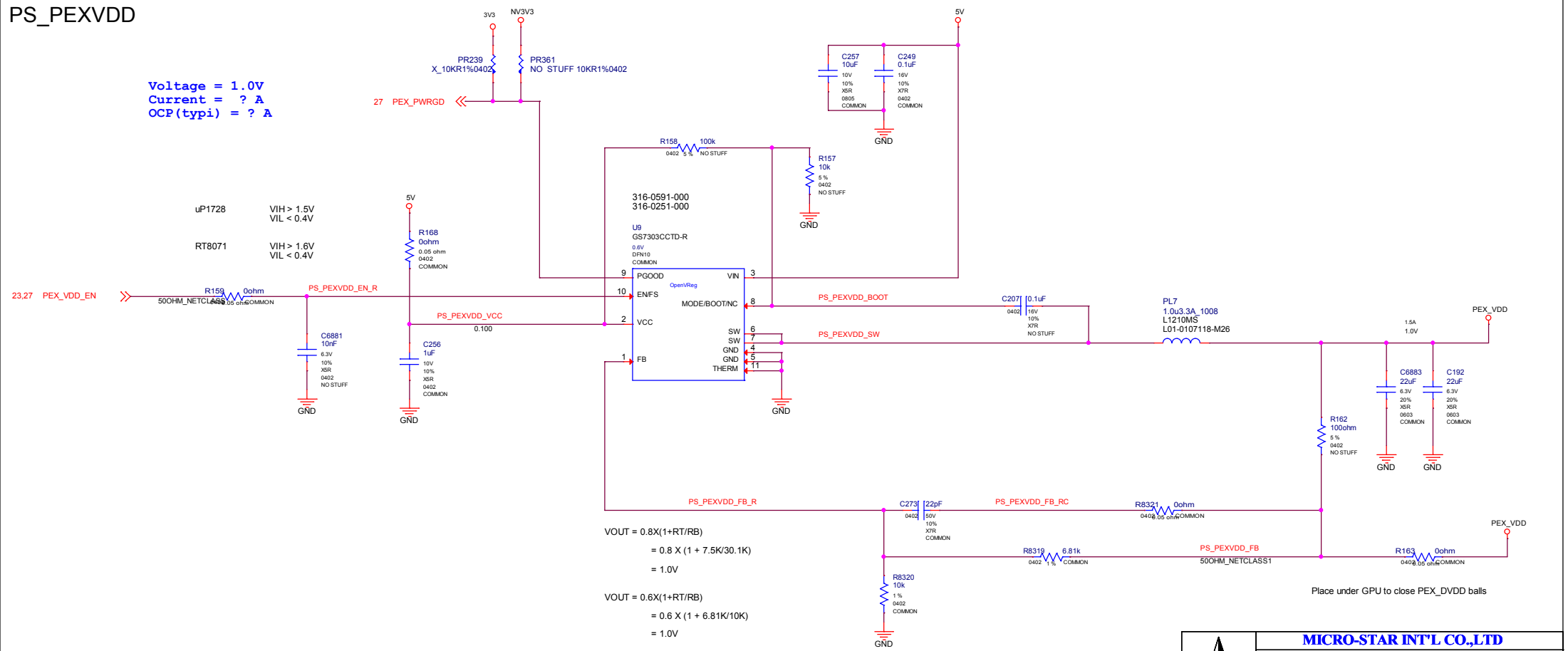

uP1728 VIH > 1.5V
 VIL < 0.4V
 RT8071 VIH > 1.6V
 VIL < 0.4V

Place under GPU to close PEX_DVDD balls



MICRO-STAR INT'L CO.,LTD		
MS-V378		
Size Custom	Document Description PS_PEXVDD	Rev 1.2
Date: Thursday, November 07, 2019	Sheet 19	of 29

BLANK

	MICRO-STAR INT'L CO.,LTD		
	MS-V378		
	Size A	Document Description PS_NV3V3	Rev 1.2
Date: Thursday, November 07, 2019		Sheet 20 of 29	

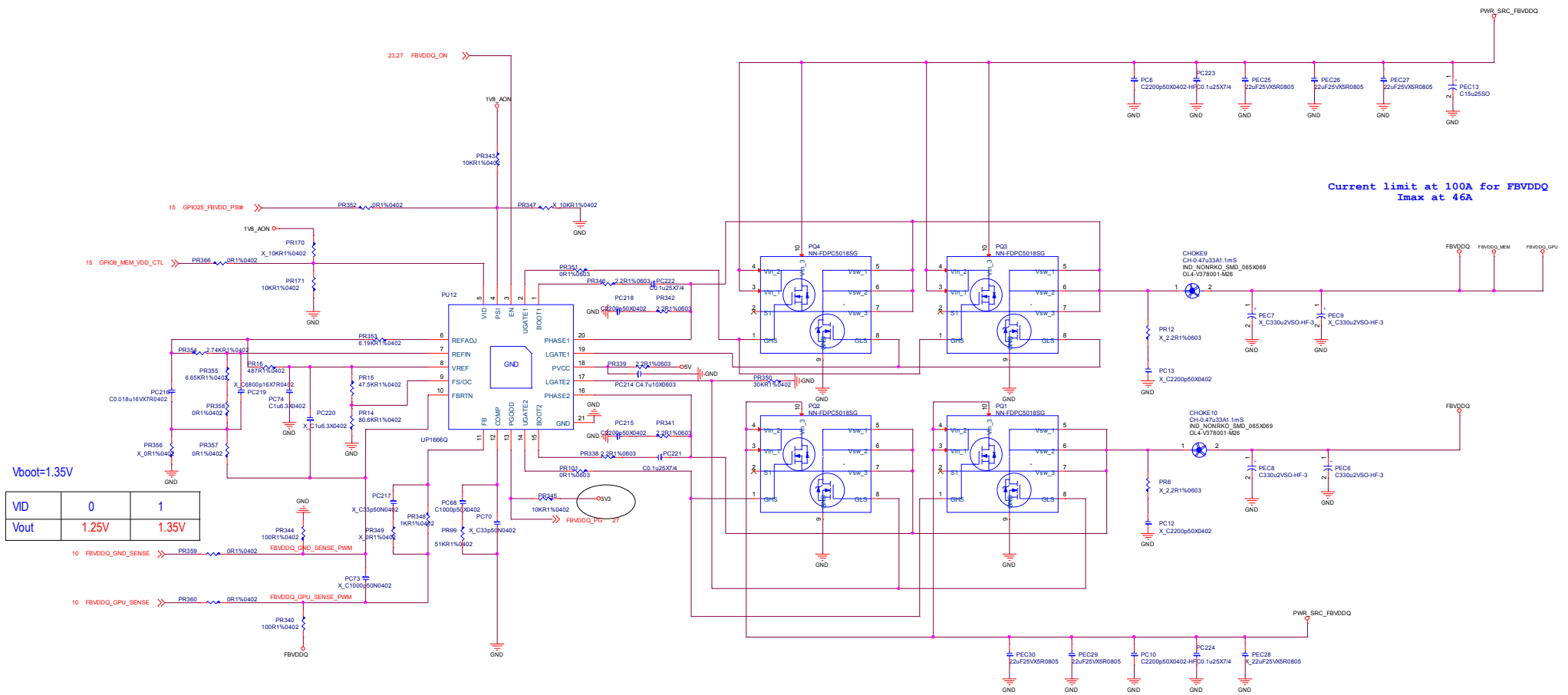

Vboot=1.35V

VID	0	1
Vout	1.25V	1.35V

Current limit at 100A for FBVDDQ
I_max at 46A

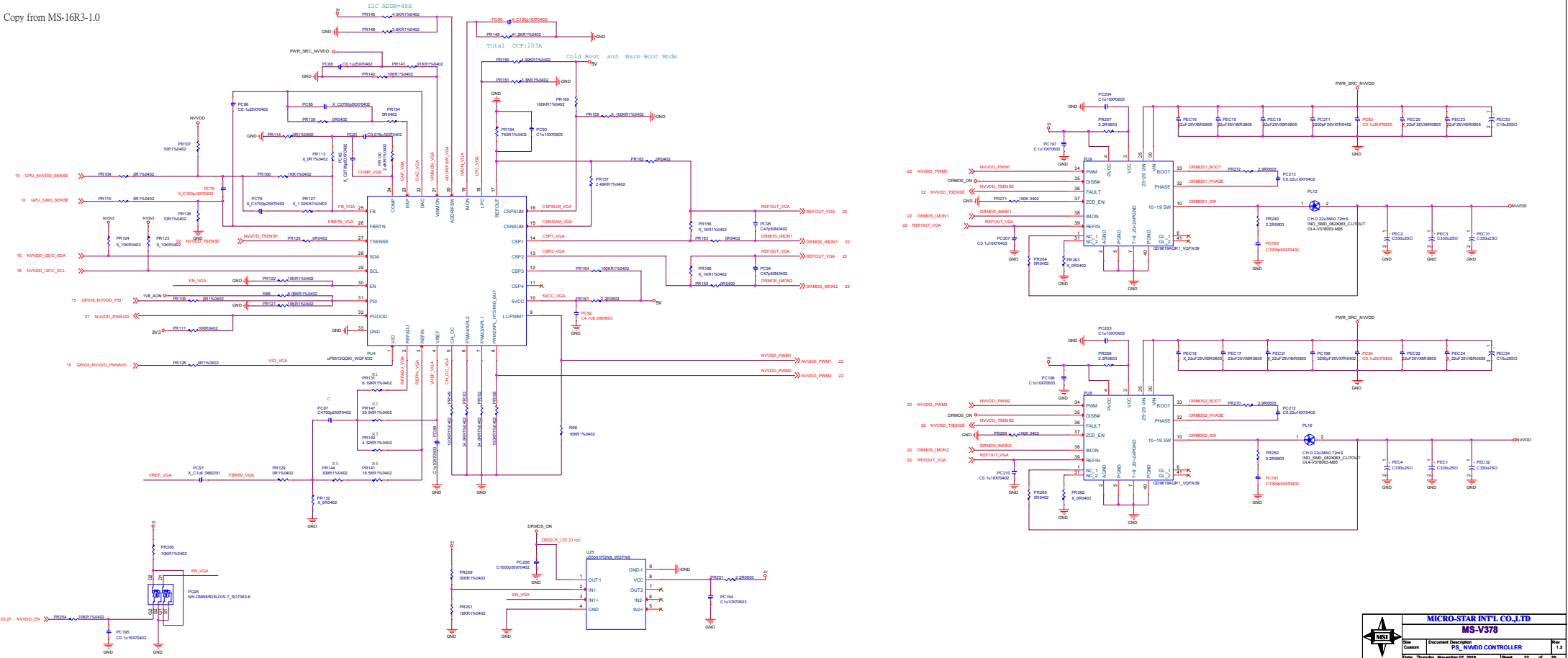

Discharge

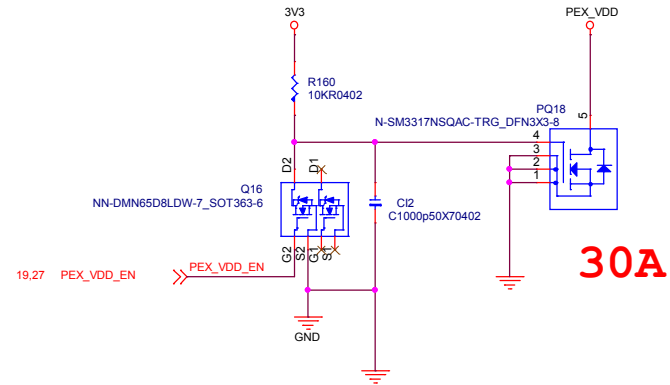
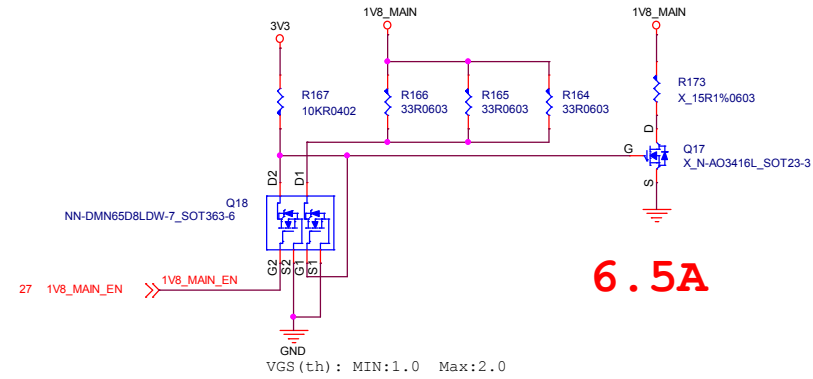
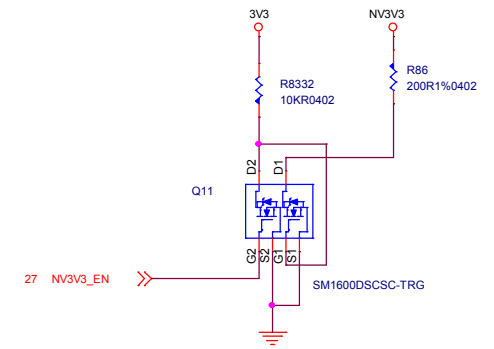
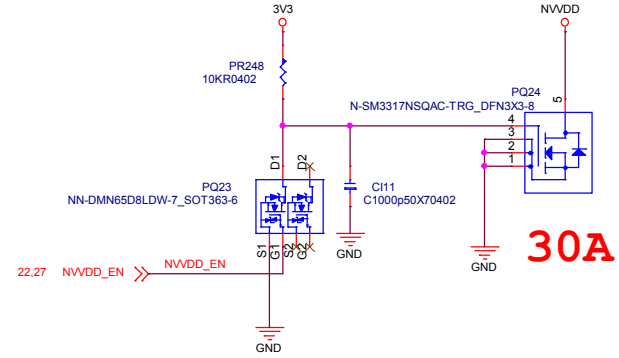
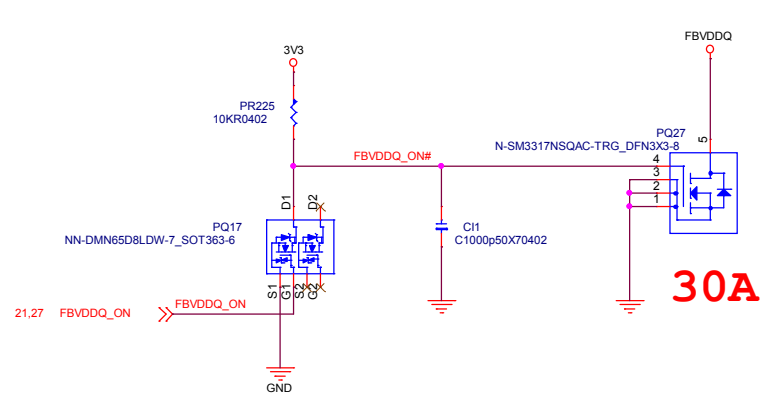

	MICRO-STAR INT'L CO.,LTD	
	MS-V378	
Size Custom	Document Description DISCHARGE	Rev 1.2
Date: Thursday, November 07, 2019		Sheet 23 of 29

Pin Name	N17P	N18P	N17P Functional Description	N17P Recommended Default Pull-up or Pull-down	N18P Recommended Default Pull-up or Pull-down
GPIO0	NVVDD_PWM	NVVDD_PWM_VID	PWM Output to control NVVDD	0 to 1V8 PWM output	
GPIO1	GC6_FB_EN	GC6_FB_EN	FB Enable for GC6 2.1	OD, 10K pull-down	OD, 10K pull-down
GPIO2	GPU_EVENT#	GPU_EVENT#	GPU wake signal for GC6 2.1	10K pull-up to 1V8 _AON	10K pull-up to 1V8 _AON
GPIO3	NVVDDS_PWM	UNUSED	PWM output to control the NVVDDS power supply	0 to 1V8 output	
GPIO4	1V8_MAIN_EN	1V8_MAIN_EN	GPU POWER Sequencing for GC6 2.1	OD, 10K pull-up to 1V8 _AON	OD, 10K pull-up to 1V8 _AON
GPIO5	FRM_LCK#	FRM_LCK#	Active low Frame Lock	OD, 10K pull-up to 1V8 _AON	OD, 10K pull-up to 1V8 _AON
GPIO6	NVVDD_PSI	NVVDD_PSI	Phase shedding	10K pull-up to 1V8 _AON	10K pull-up to 1V8 _AON
GPIO7	LCD_BL_PWM	LCD_BL_PWM	Panel Backlight PWM Brightness Control	100K pull-down	100K pull-down
GPIO8	MEM_VDD_CTL	MEM_VDD_CTL	Memory Voltage Control	pull-up/pull-down to set the FBVDD/Q power-on voltage	pull-up/pull-down to set the FBVDD/Q power-on voltage
GPIO9	THERM_ALERT	THERM_ALERT	Active Low Thermal Alert	OD, 10K pull-up to 1V8_AON	OD, 10K pull-up to 1V8_AON
GPIO10	MEM_VREF_CTL	MEM_VREF_CTL	Memory VREF Control	100K pull-down	100K pull-down
GPIO11	LCD_VCC	LCD_VCC	Panel Power Enable	100K pull-down	100K pull-down
GPIO12	PWR_LEVEL	PWR_LEVEL	AC power detect or power supply overdraw input	100K pull-up to 1V8_AON	10K pull-up to 1V8_AON
GPIO13	LCD_BLEN	UNUSED	Panel Backlight Enable	100K pull-down	
GPIO14	HPD_A	HPD_A	Hot Plug Detect for IFPA		10K pull-up to 1V8_AON
GPIO15	HPD_B	HPD_B	Hot Plug Detect for IFPB		10K pull-up to 1V8_AON
GPIO16	SYS_PEX_RST_MON#	UNUSED	System side PCIe reset monitor	10K pull-up to 1V8 _AON	
GPIO17	HPD_D	HPD_D	Hot Plug Detect for IFPD		10K pull-up to 1V8_AON
GPIO18	HPD_E	HPD_E	Hot Plug Detect for IFPE		10K pull-up to 1V8_AON
GPIO19	3DVision	UNUSED	3D Vision L/R signal	100K pull-down	
GPIO20	GC5_MODE	NB_GC6			10K pull-down
GPIO21	UNUSED	LCD_BLEN			100K pull-down
GPIO22	UNUSED	ADC_MUX_SEL			2.2K pull-up See Circuit
GPIO23	GPU_PEX_RST_HOLD#	RESERVED	GPU PCIe self-reset control	OD, 10K pull-up to a gated 3V3	100K pull-down
GPIO24	HPD_F	UNUSED	Hot Plug Detect for IFFF		
GPIO25	UNUSED	FBVDD_PSI#			
GPIO26	UNUSED	FP_FUSE			10K pull-down
GPIO27	HPD_C	HPD_C	Hot Plug Detect for IFPC		10K pull-up to 1V8_AON

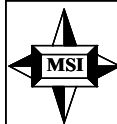

MICRO-STAR INT'L CO.,LTD

MS-V378

Size B	Document Description GPIO Functional Description	Rev 1.2
Date: Thursday, November 07, 2019		Sheet 24 of 29

INPUT PREFILTER

On Semi	PR90, PR91	PR92, PR133	PR108	PR95, PR103	PC64, PC71
CONFIG	R954, R924	R977, R923	R950	R953, R952	C841, C836
N18P-G0	649R	475R	243K	75K	1.0nF

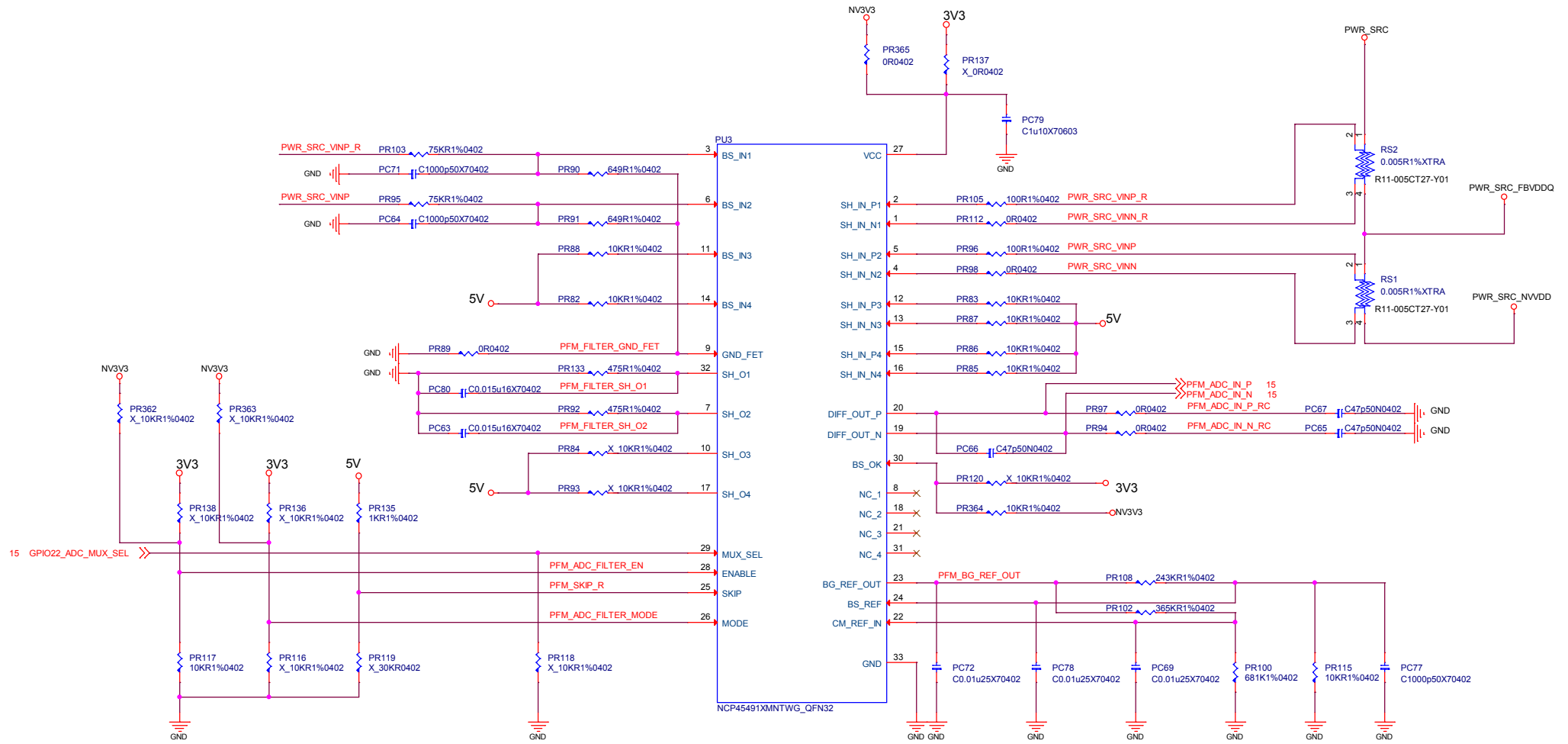

	MICRO-STAR INT'L CO.,LTD		
	MS-V378		
	Size Custom	Document Description INPUT PREFILTER	Rev 1.2
Date: Thursday, November 07, 2019		Sheet	25 of 29

SEQUENCE:5V,1V8,NV3V3 ENABLE

DP_AUX Protection

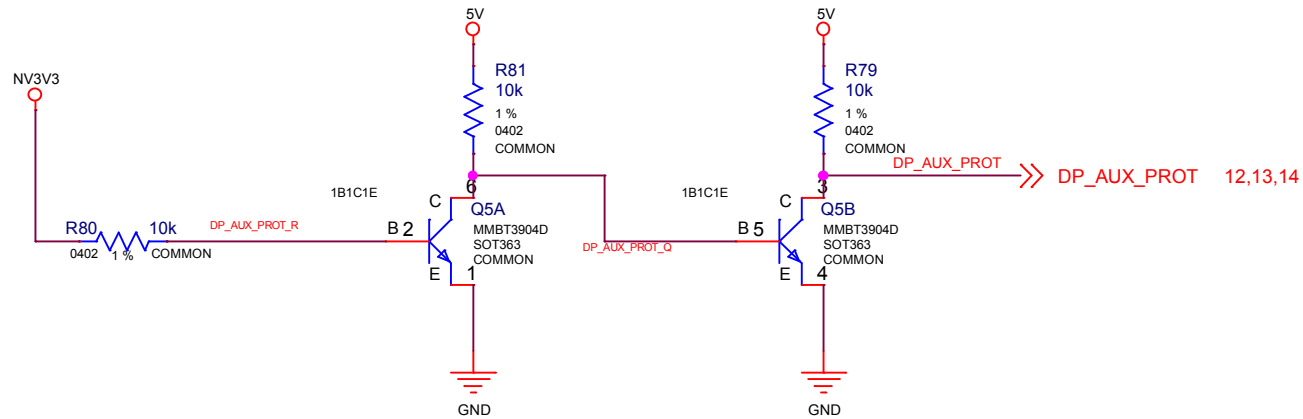

	MICRO-STAR INT'L CO.,LTD		
	MS-V378		
Size A	Document Description DP_AUX Protection	Rev 1.2	
Date: Thursday, November 07, 2019		Sheet	26 of 29

Power Sequence Control

POWER ON= 1V8_AON->1V8_MAIN->NV3V3->NVVDD->PEX_VDD->FBVDDQ->DGPU_PWRGD

POWER OFF= PEX_VDD/FBVDDQ->NVVDD->NV3V3->1V8_MAIN->1V8_AON

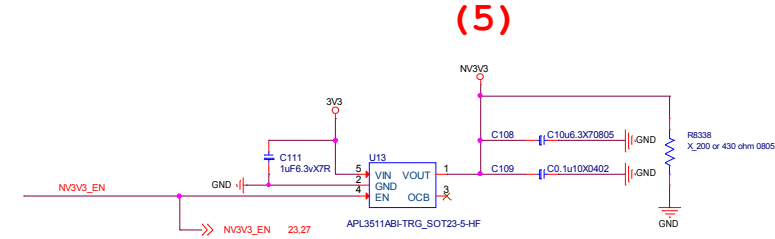
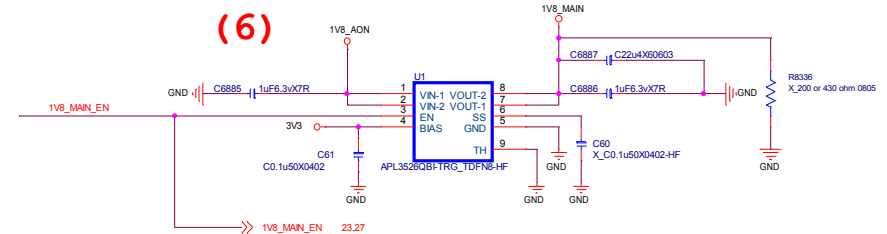
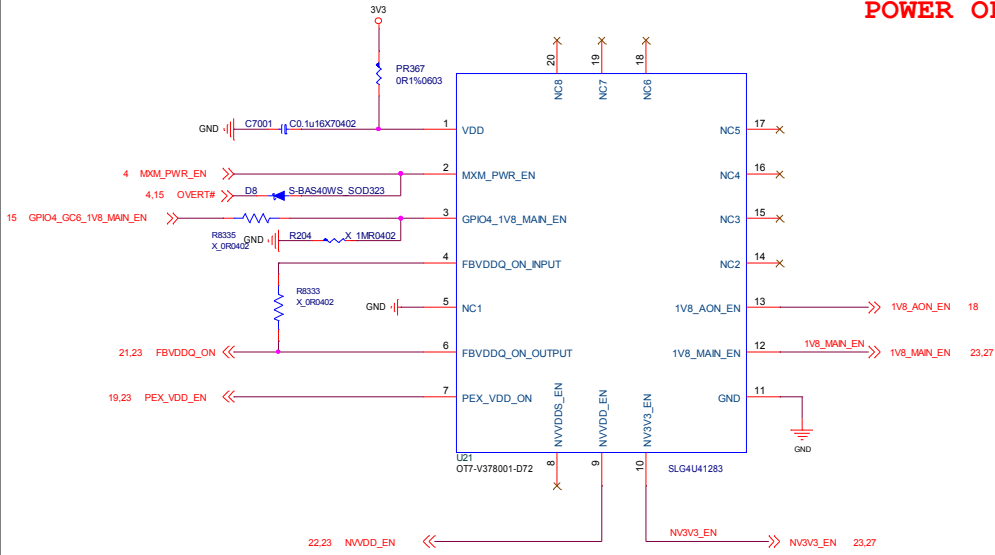

SOFTSTRAT=400us

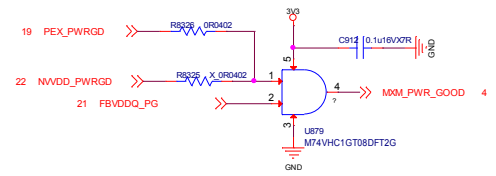

MSI			
MICRO-STAR INT'L CO.,LTD			
MS-V378			
Size	Document Description	Sequence	Rev
Custom			1.2
Date:	Thursday, November 07, 2019	Sheet	27 of 29

SEQUENCE:DISCHARGE

	MICRO-STAR INT'L CO.,LTD	
	MS-V378	
Size B	Document Description SEQUENCE_DISCHARGE	Rev 1.2
Date: Thursday, November 07, 2019		Sheet 28 of 29

MECH

Mounting Holes

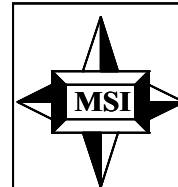
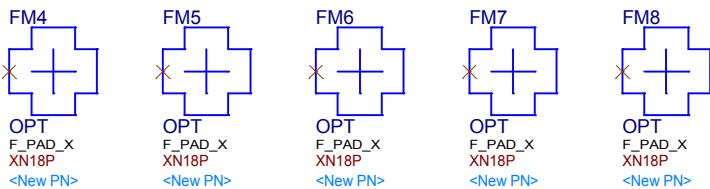
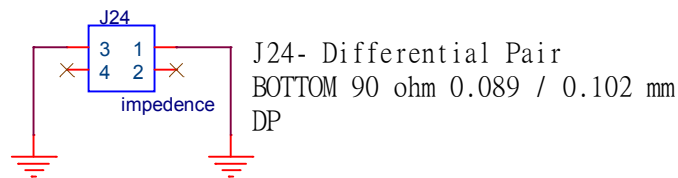
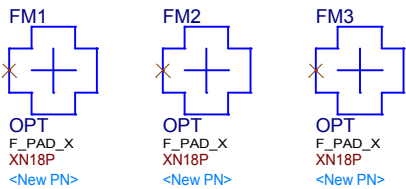
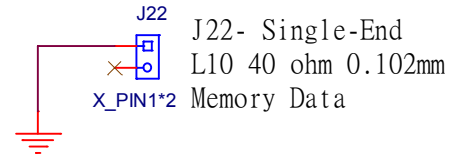
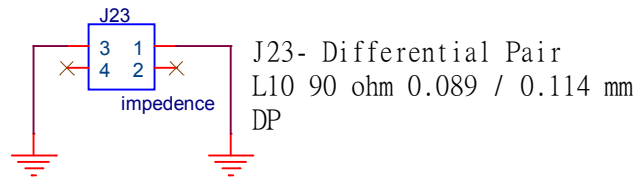
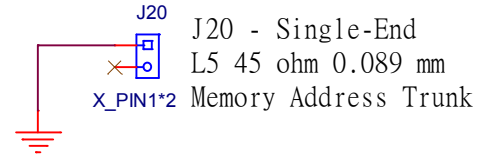
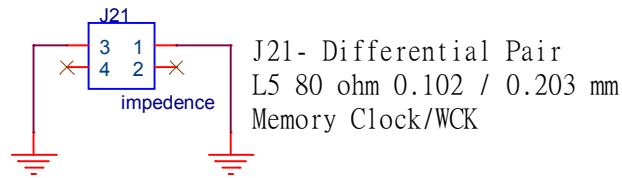
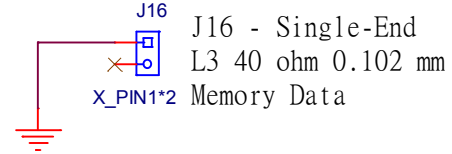
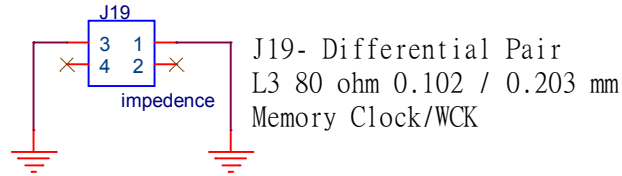
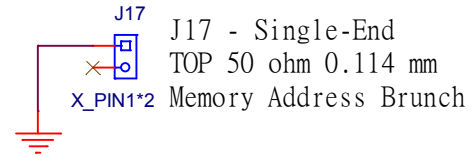
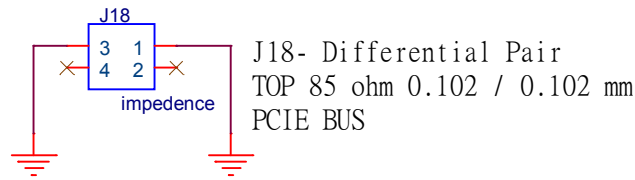
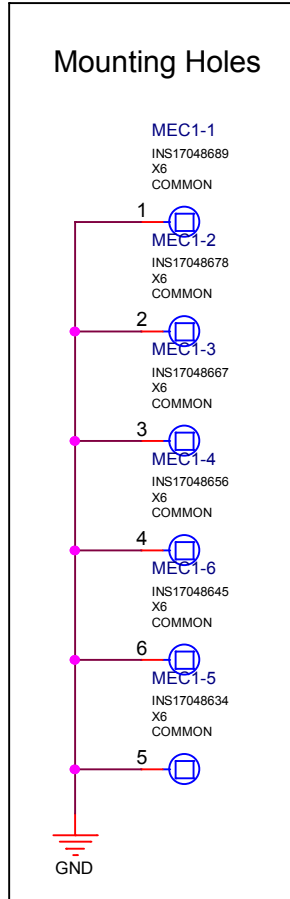

MICRO-STAR INT'L CO.,LTD

MS-V378

Size A	Document Description MECH	Rev 1.2
Date: Thursday, November 07, 2019		Sheet 29 of 29