

Check BOM for more detail

(7) ELLEMERE GPIO STRAP OF XTAL

IO ADDRESS	FUNCTION	DEVICE

IO ADDRESS	FUNCTION	DEVICE

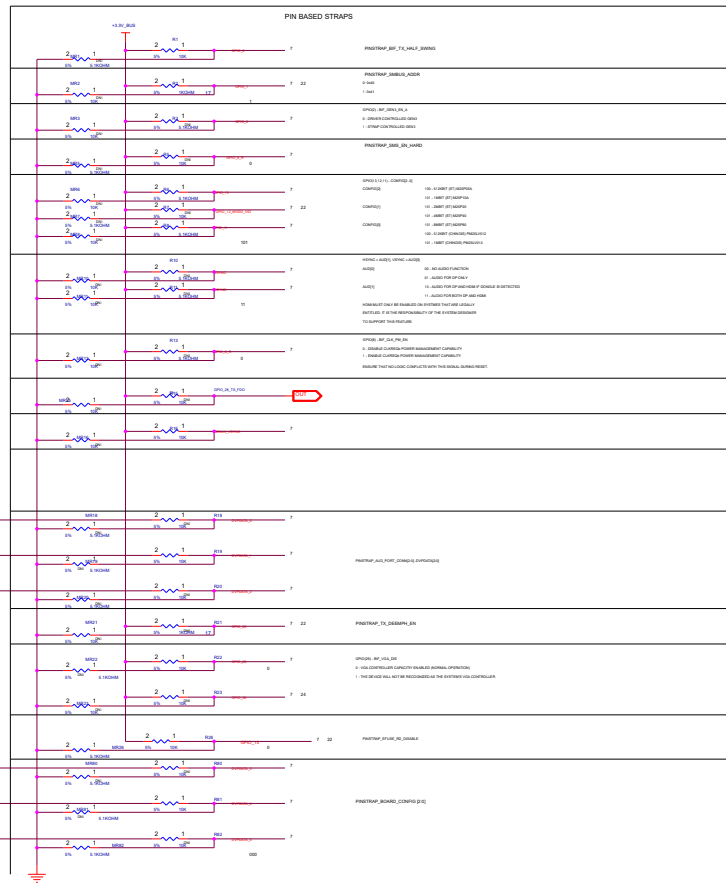
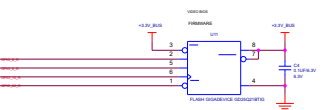
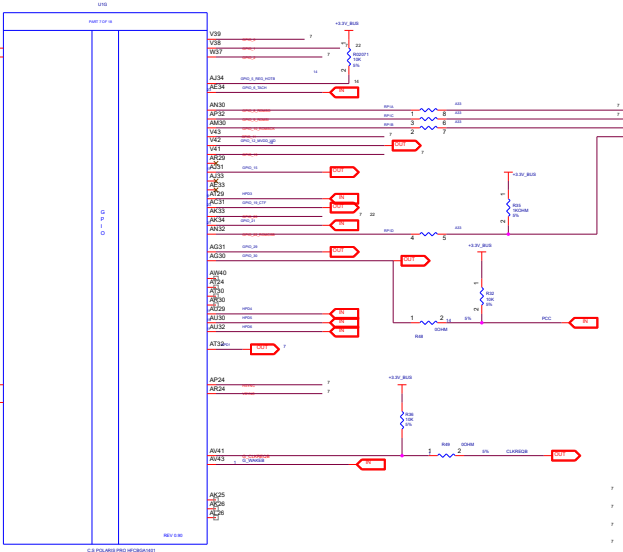
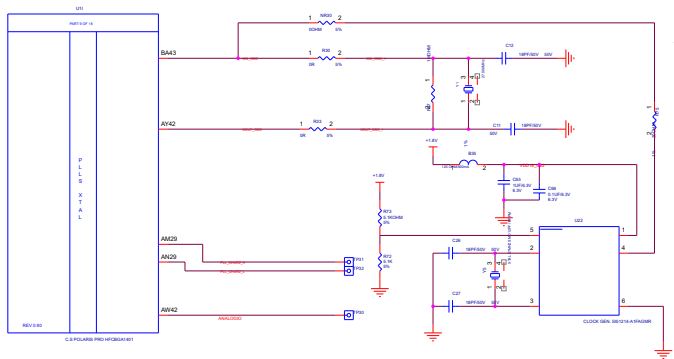
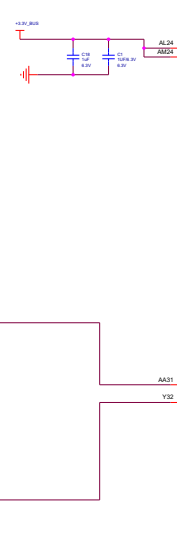
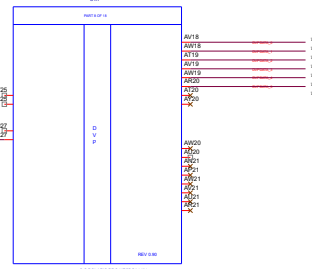
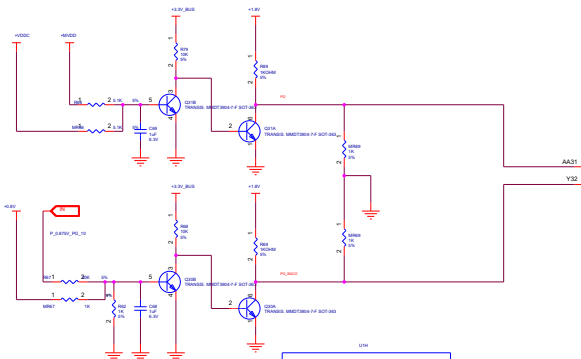

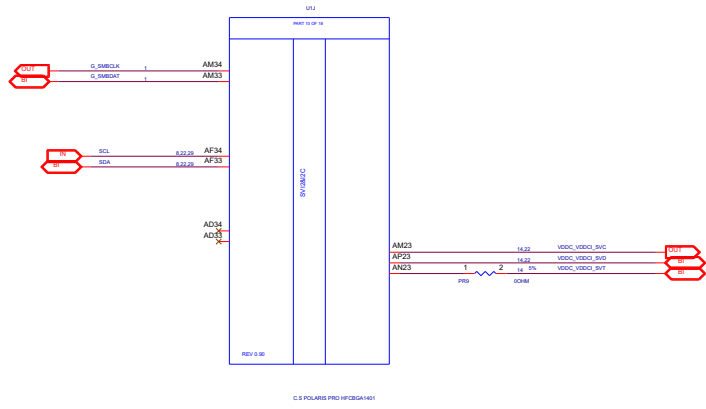

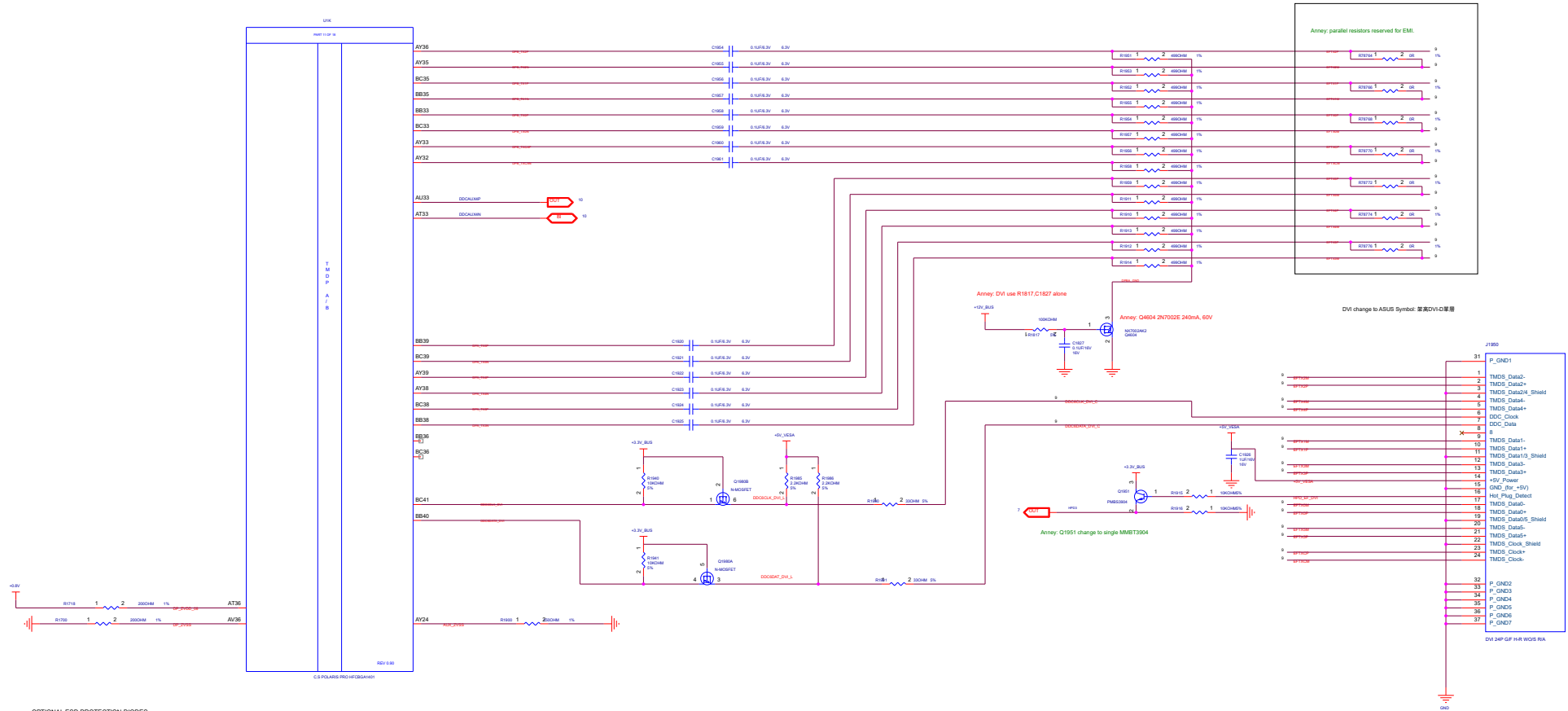

OPTIONAL ESD PROTECTION DIODES

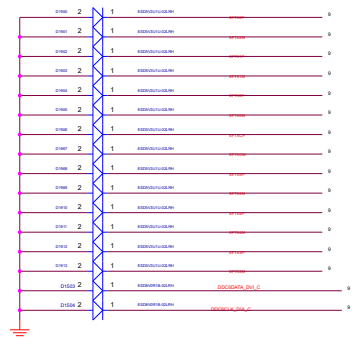

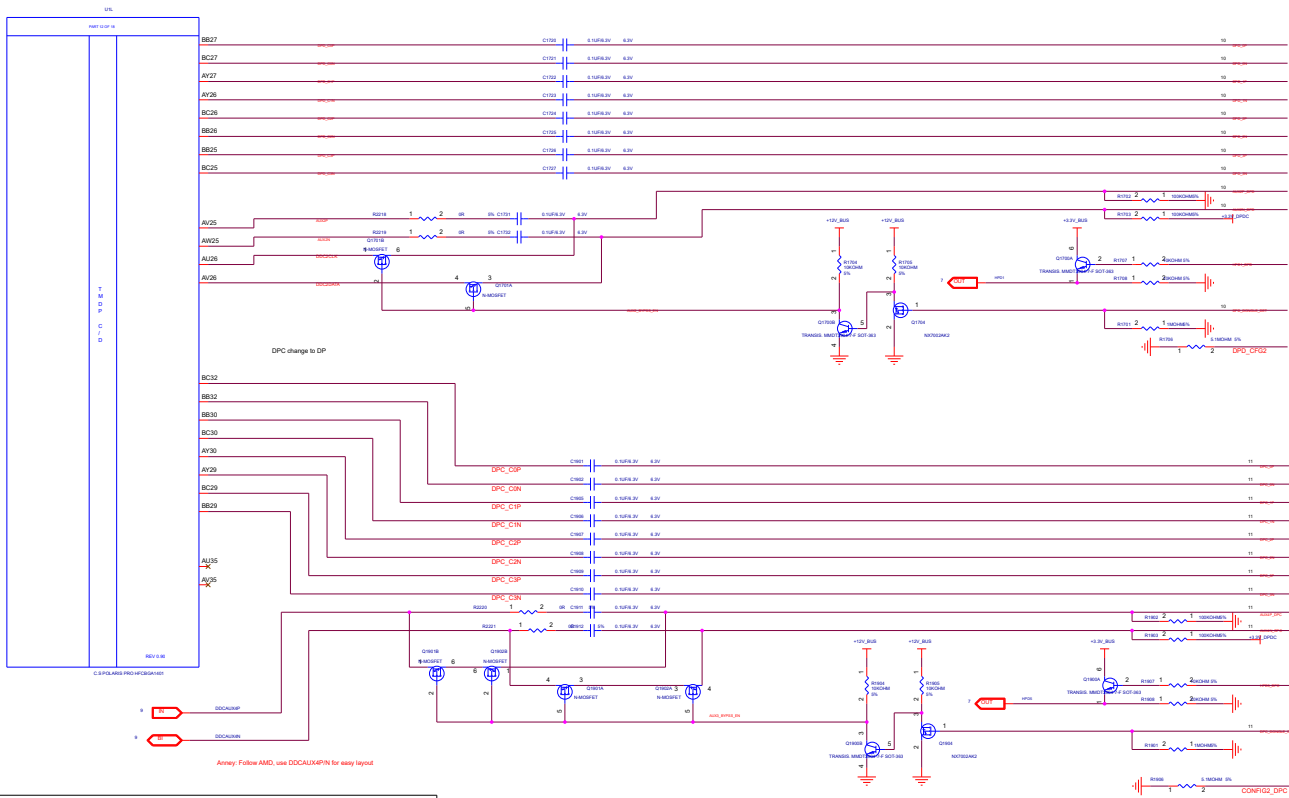

Anney: Change to SMT POOL SYMBOL

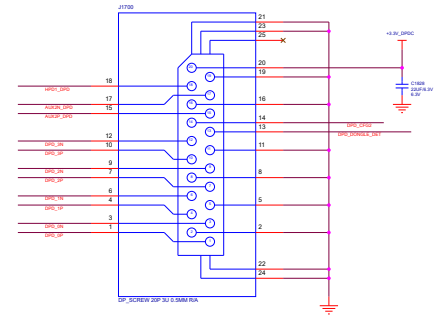

Anney: Change to SMT POOL SYMBOL

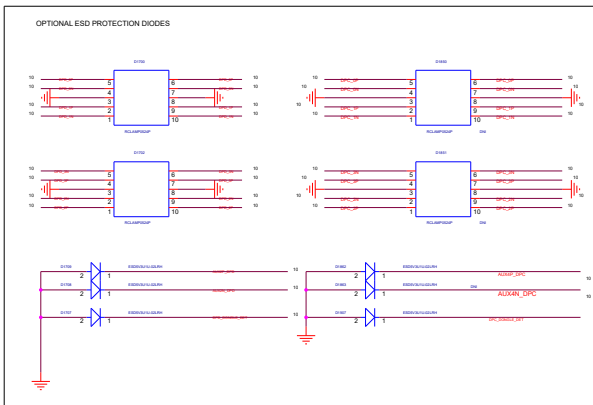
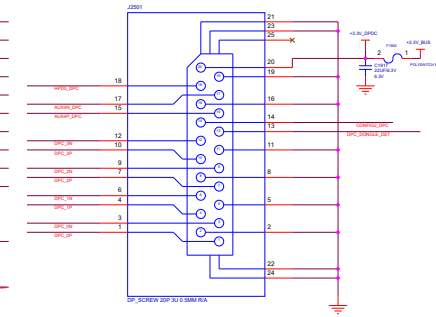

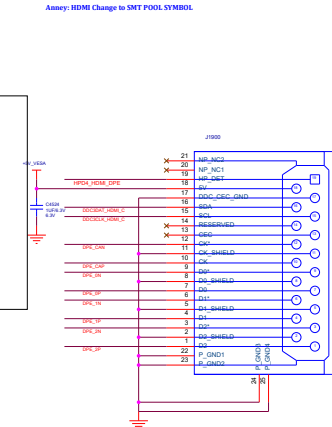
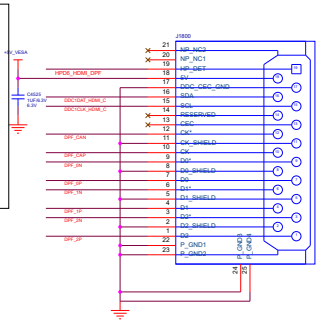
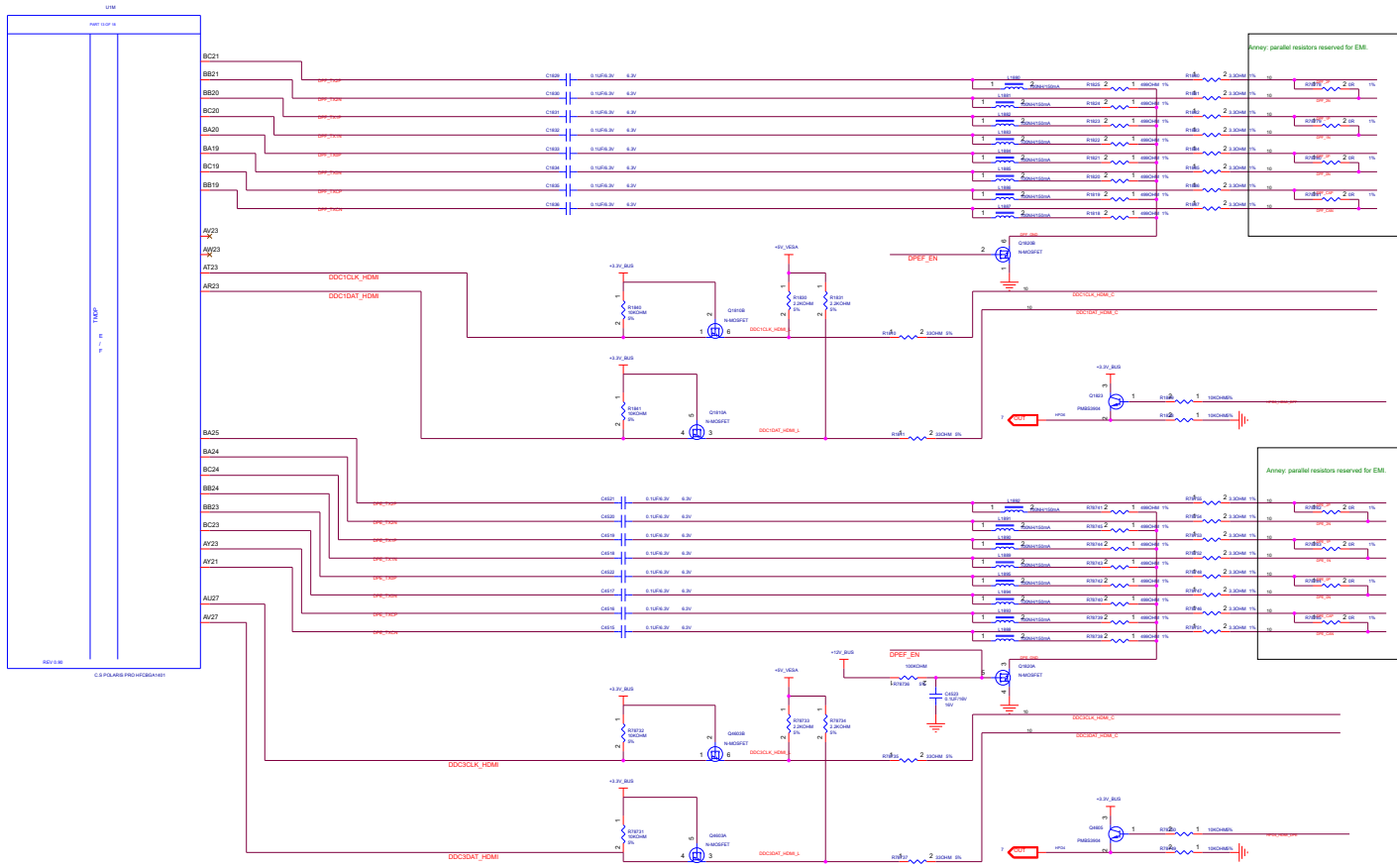

OPTIONAL ESD PROTECTION DIODES

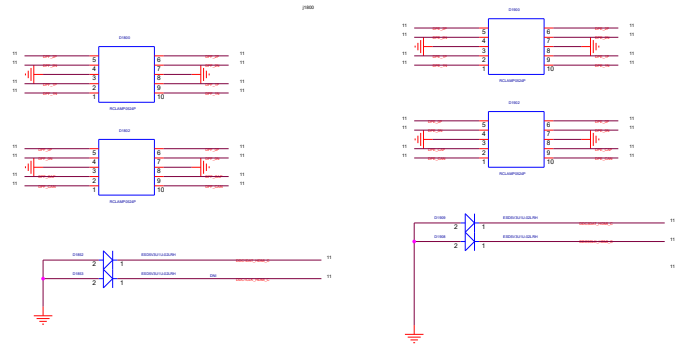

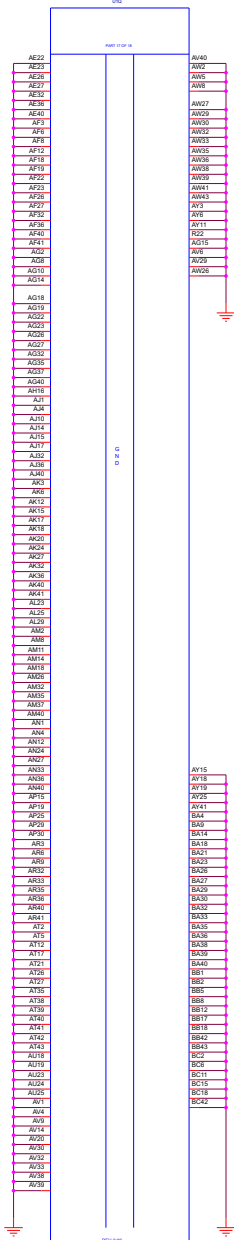
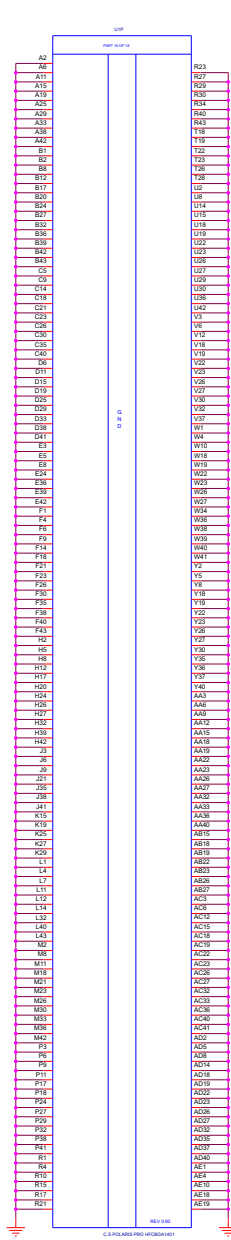

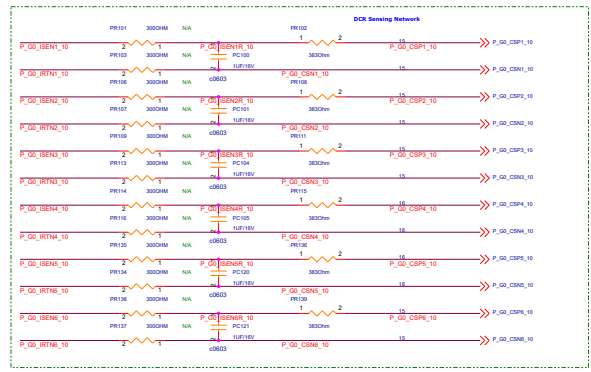
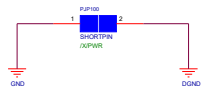
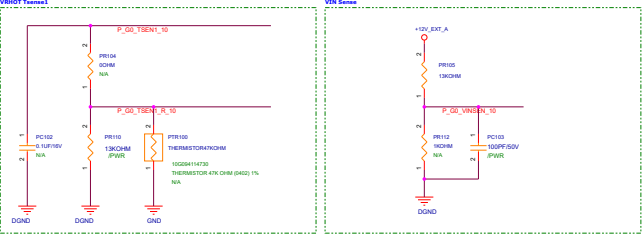

(14) Power VDDC Controller

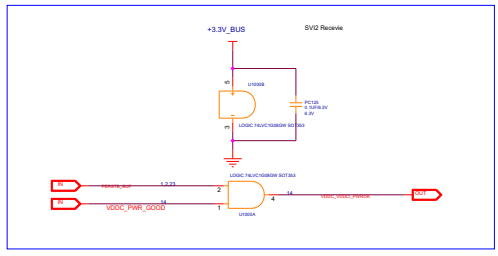
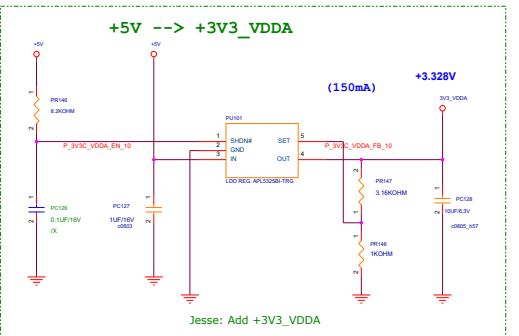
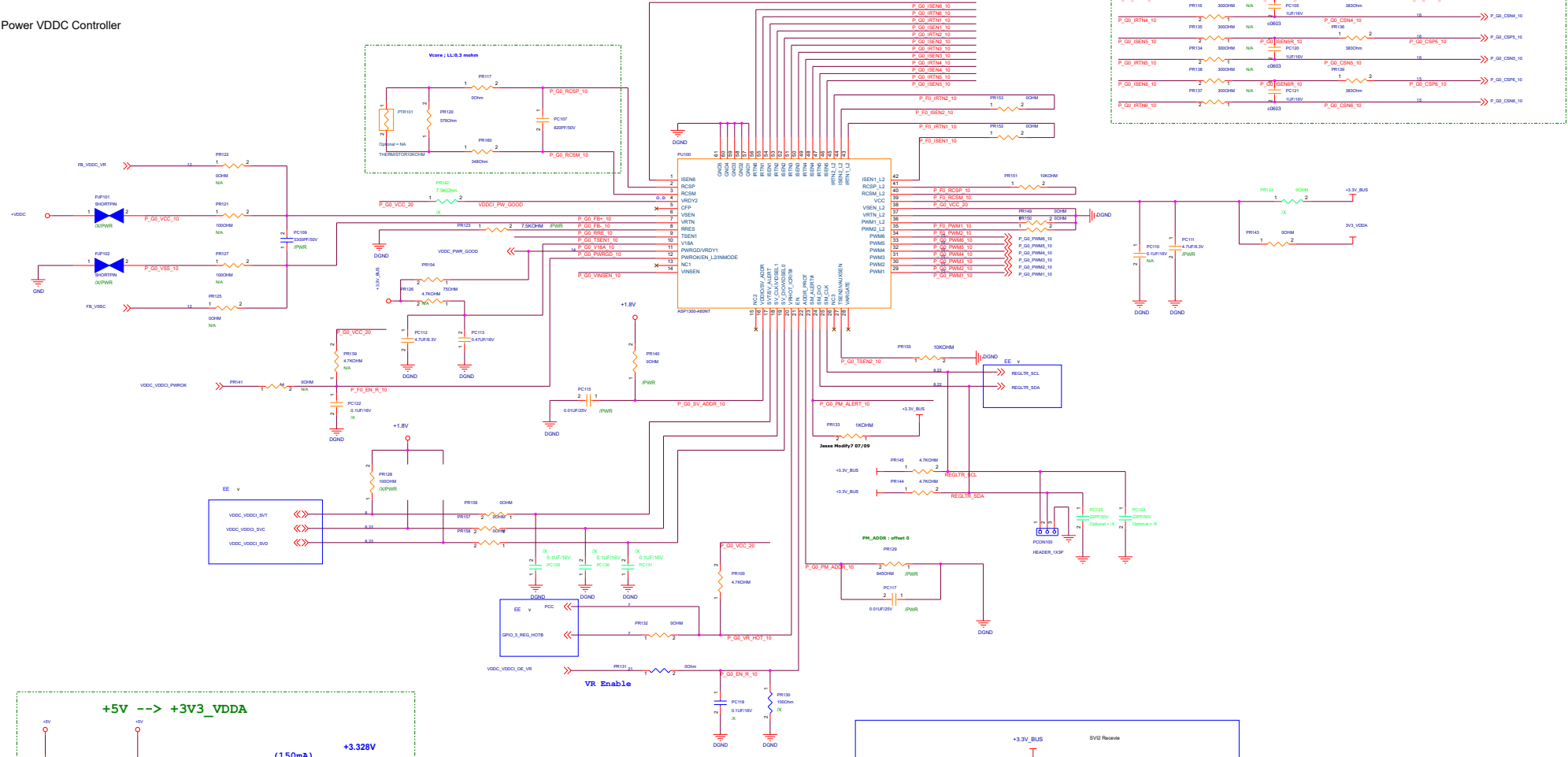

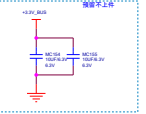
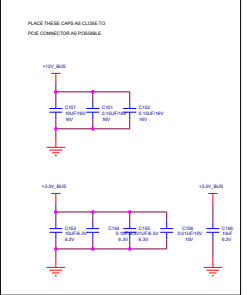
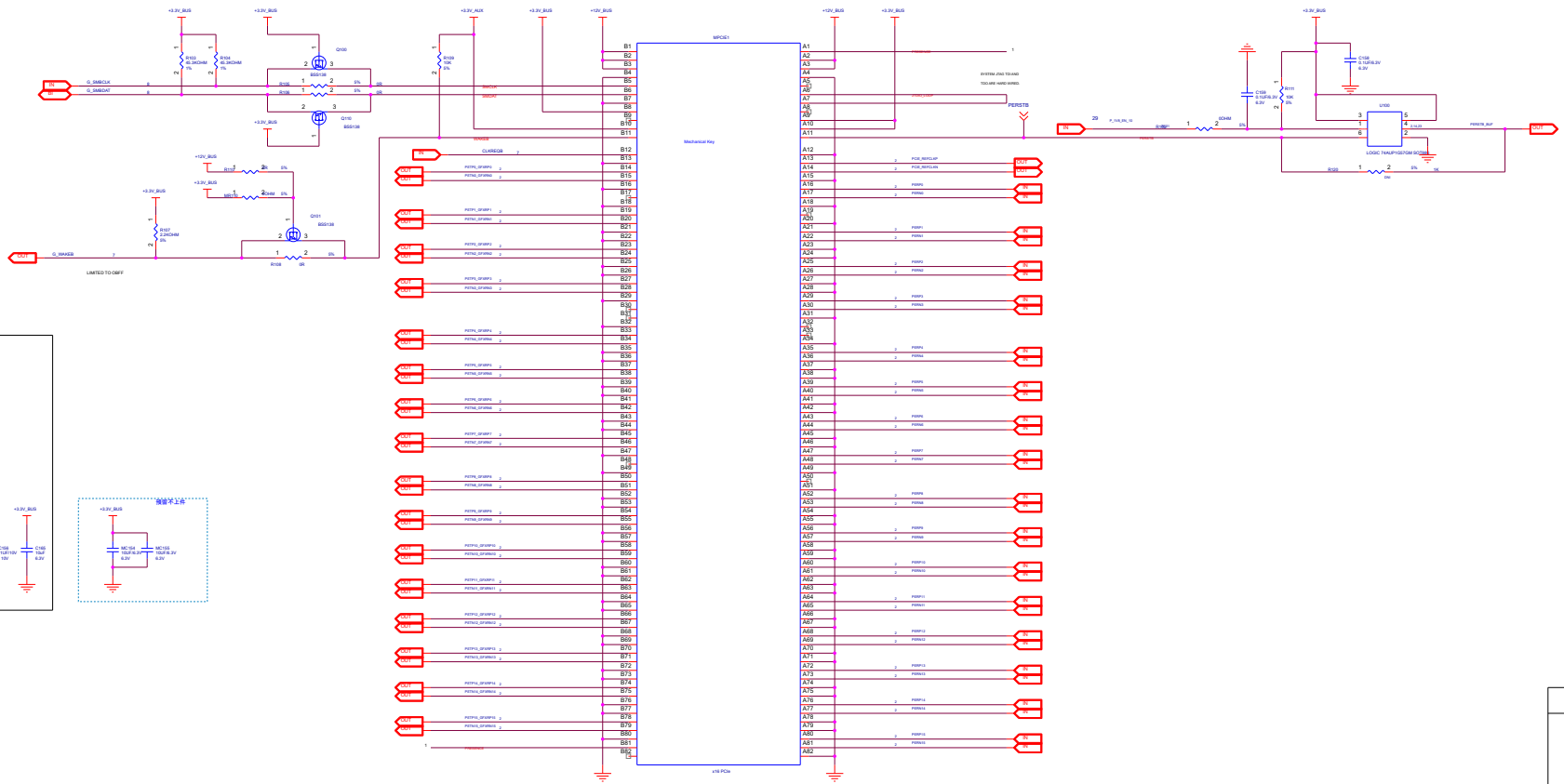

SYMBOL LEGEND

DB	DB-44P
DB	DB-9P
***	ACTIVE
---	LINE
---	WIRE OR DRY
⊥	DRILL
⊥	DRILL
⊥	DRILL
⊥	DRILL

(20) SMALL RAIL REGULATORS

12V_PEX6 --> +0.9V

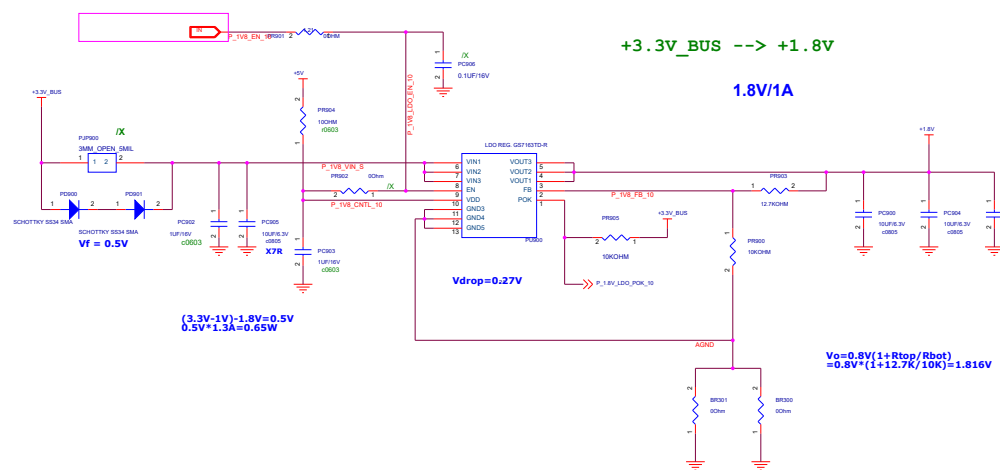
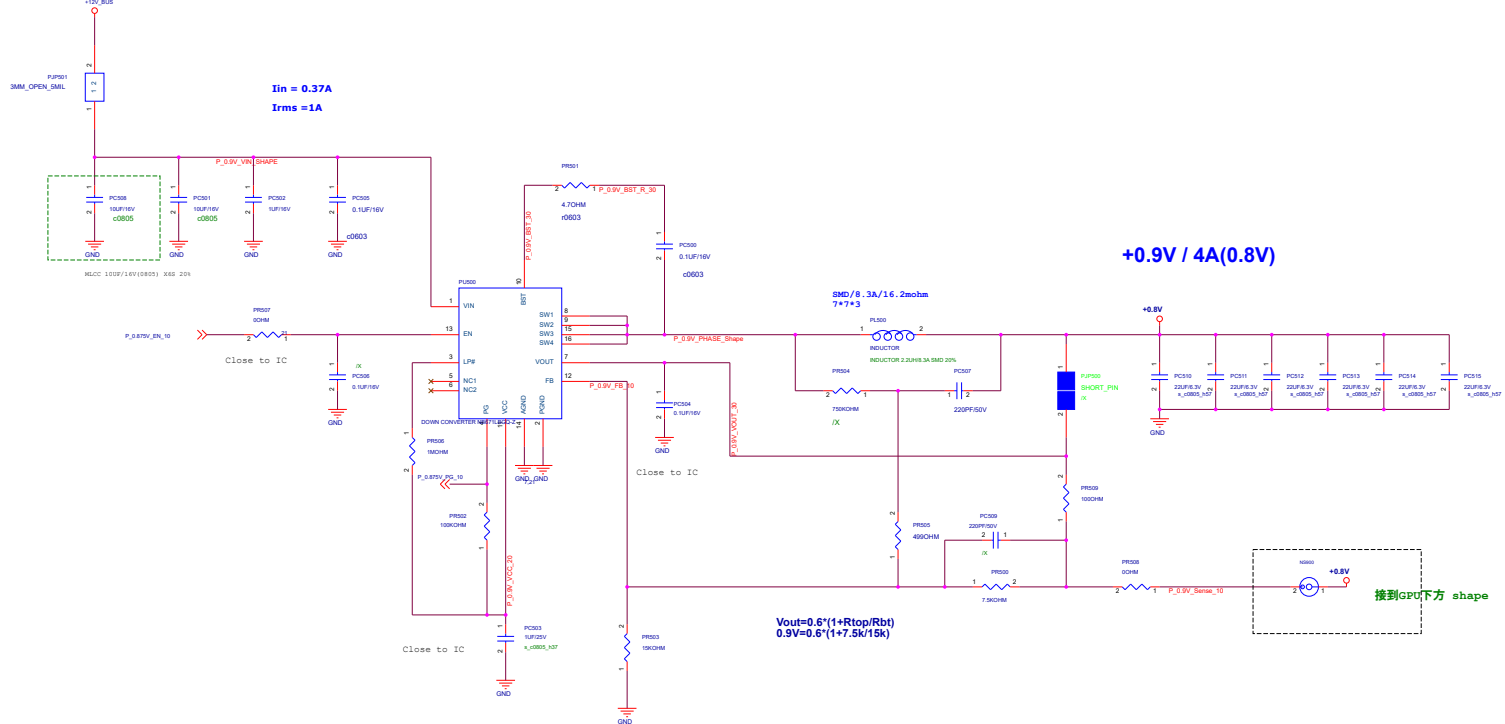

(21) POWER MANAGEMENT

Input source

PEX 3V3 INPUT - 10W



PEX_12V INPUT - 66W



PEX8 INPUT - 150W

MUST BE ATTACHED AND POWERED TO START BOARD

change 變換料號12015-00054600

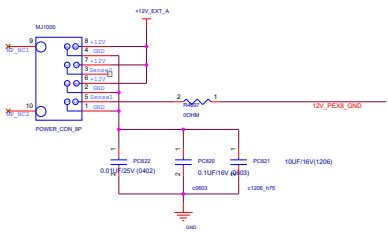

Ext Power detect

LED light	
Cable Inserted	Green
Cable Removed	Red

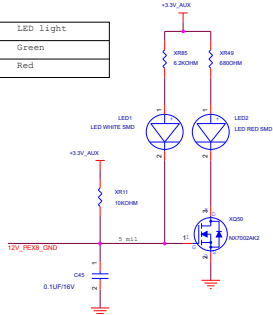

1.8V Enable

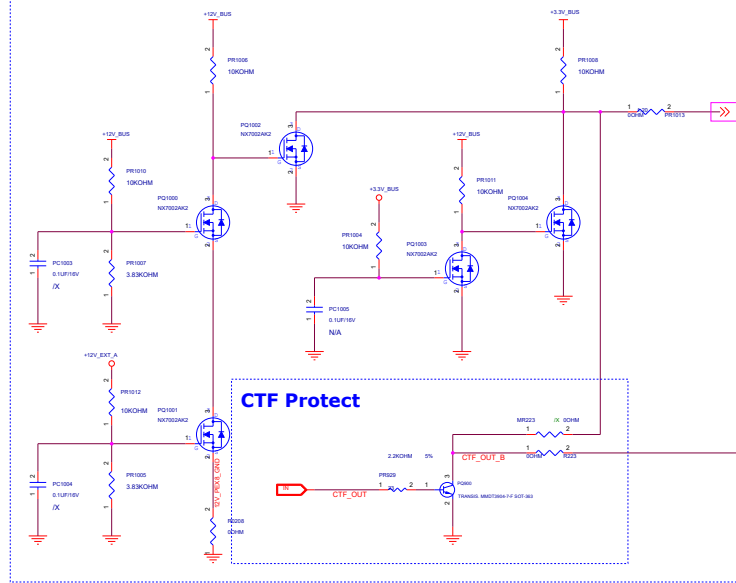

MVDD Power up Sequencing

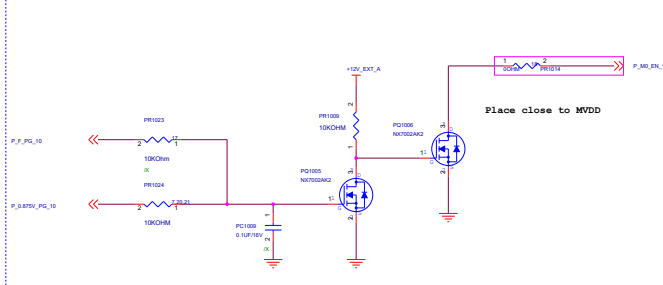

0.875V VDDC/VDDCI Power up Sequencing

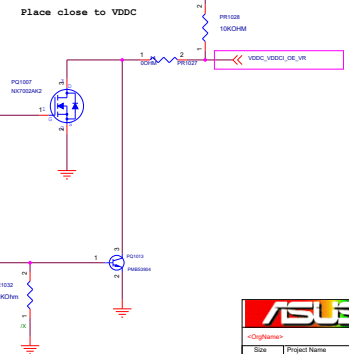
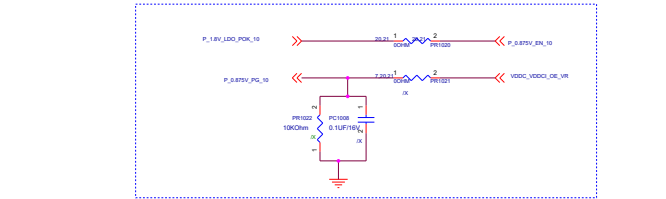

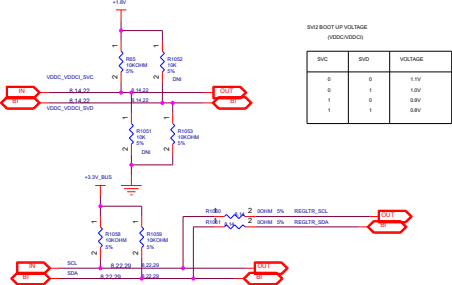

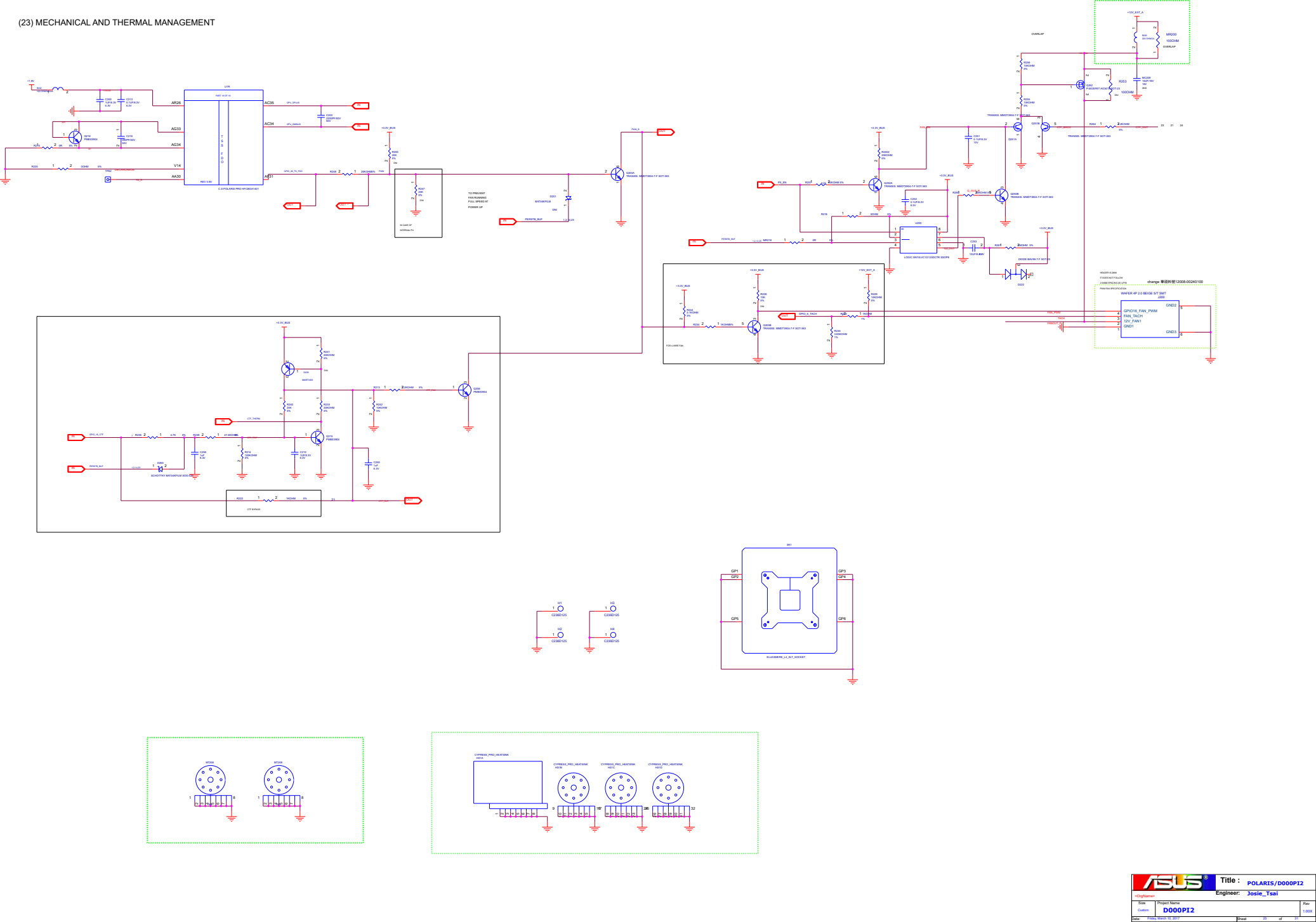

Power Flow

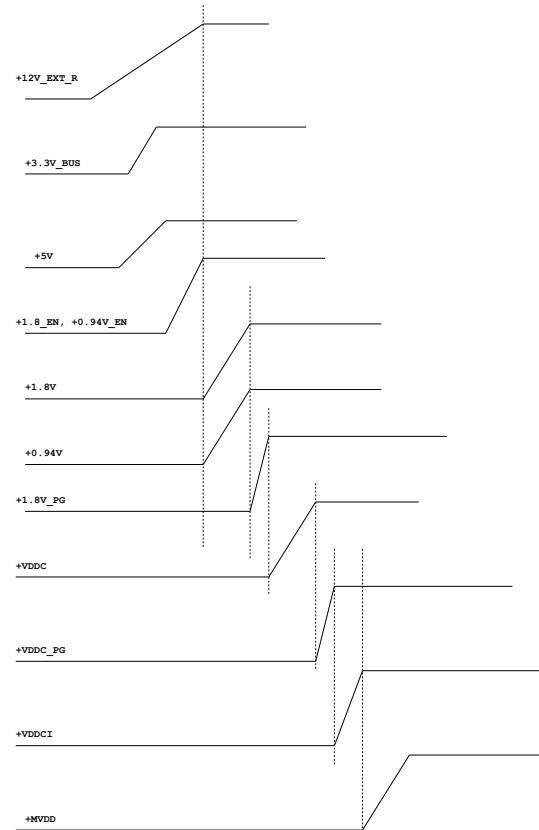
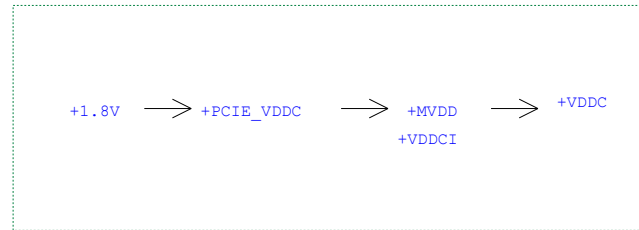
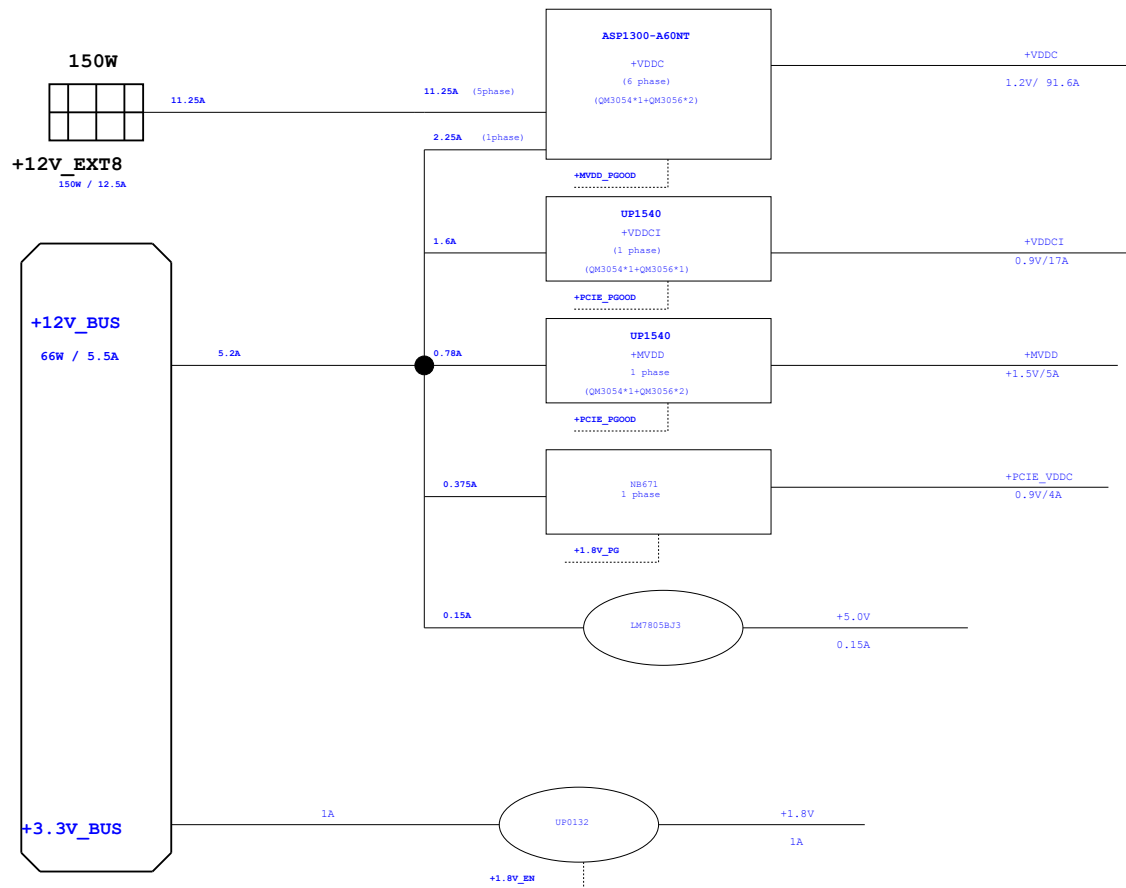
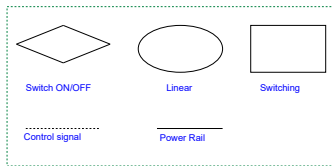

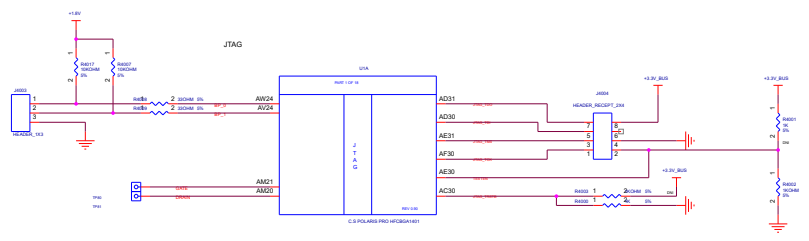

E-FUSE CAPABILITY
 DEFAULT = GPIO-CONTROLLED
 (MANUAL OPTION AS BACK-UP)

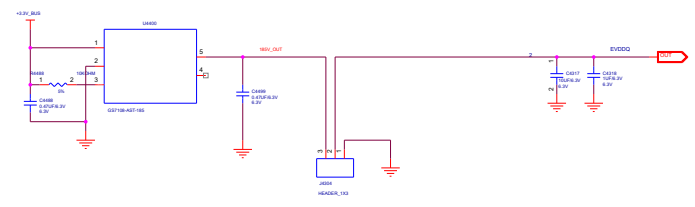

PCC Delete

1. Add 0010 to column 1000
2. Add 0000 to column 1000

MEMO

ADD 0010 to column 1000
ADD 0000 to column 1000
Version: 0.0.1 (2017.03.10)

		Title : POLARIS/C940PI	
Engineer: Josie_Tsai			
Rev: 1.00X	Project Name: C940PI	Date: 2017.03.10	File: 1.00X
		Sheet: 08	of: 10

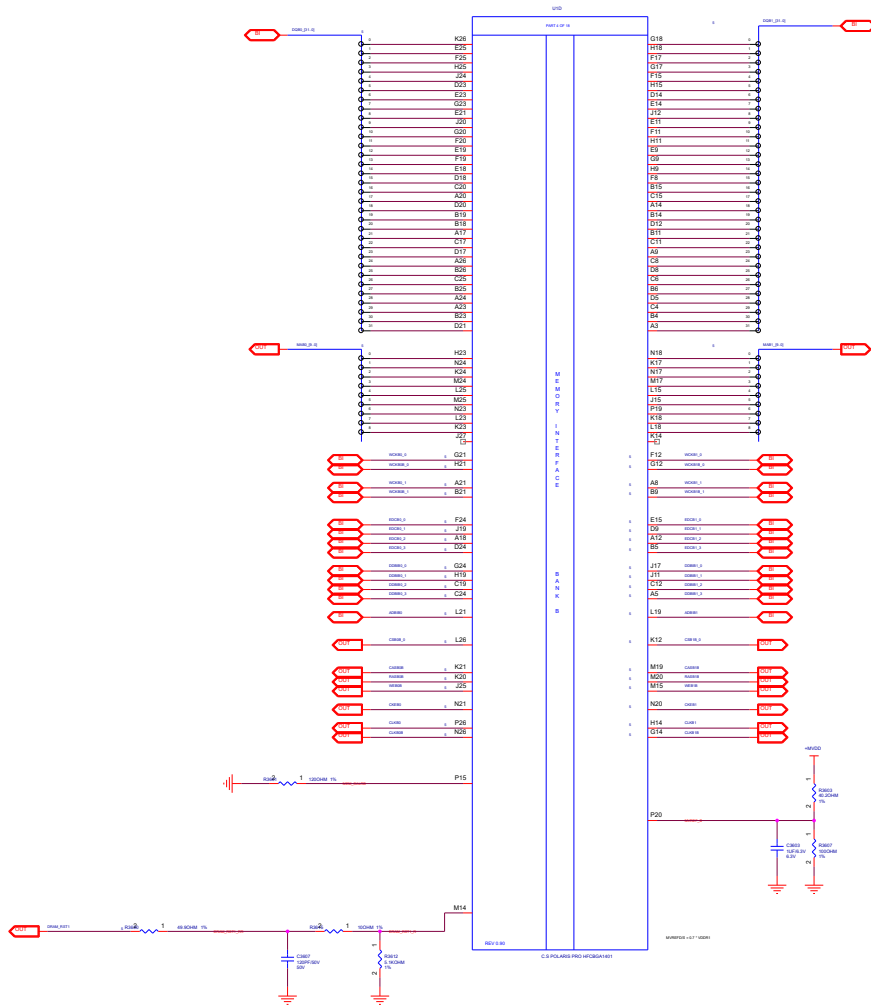
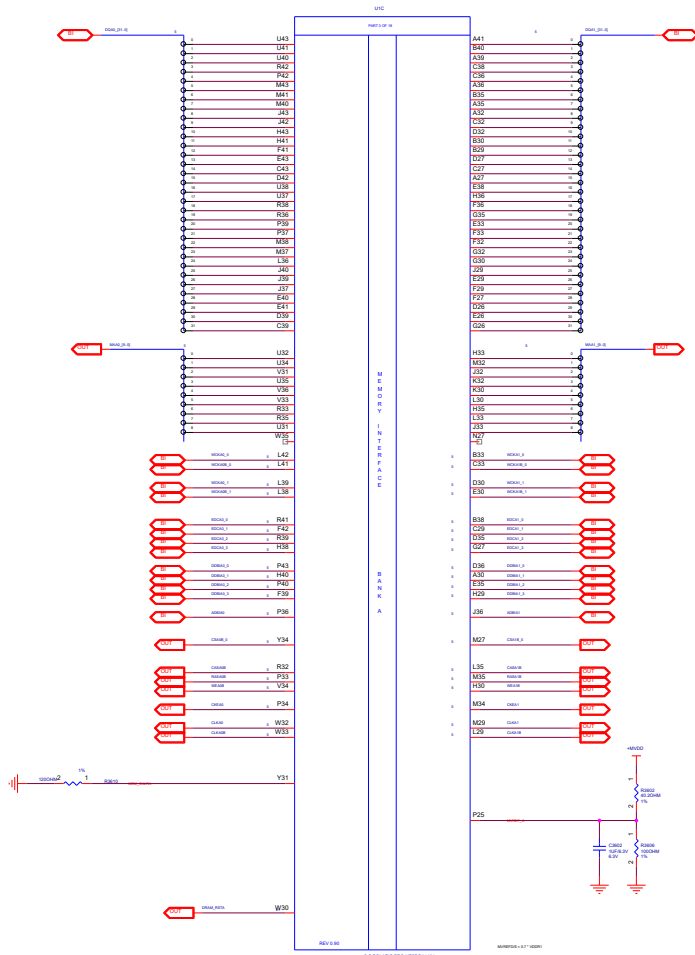

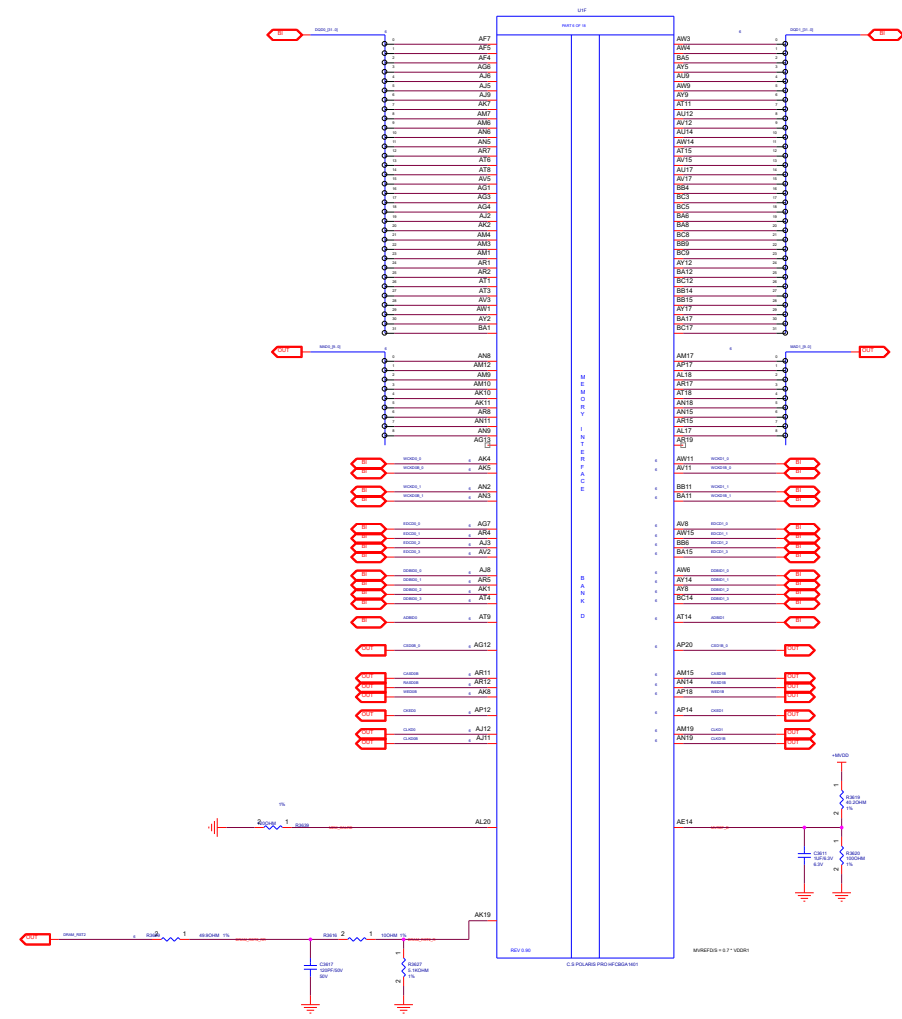
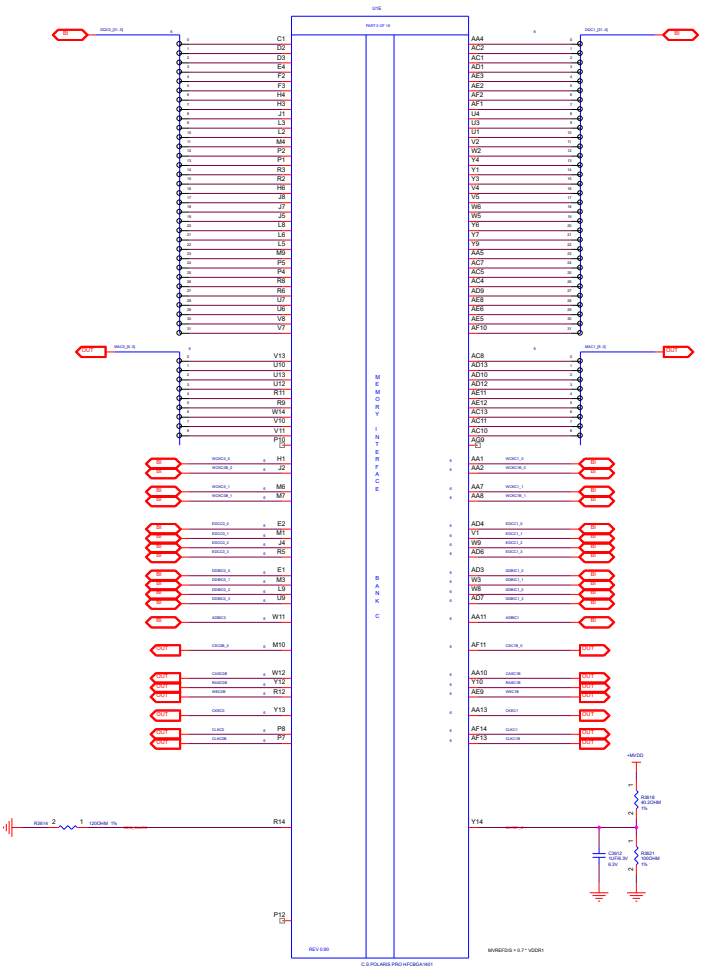

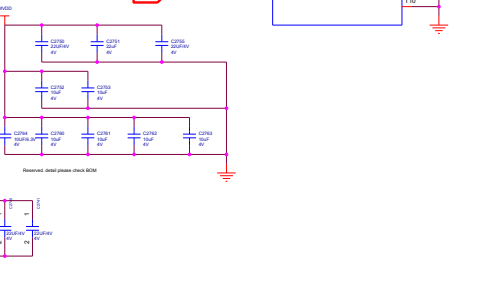
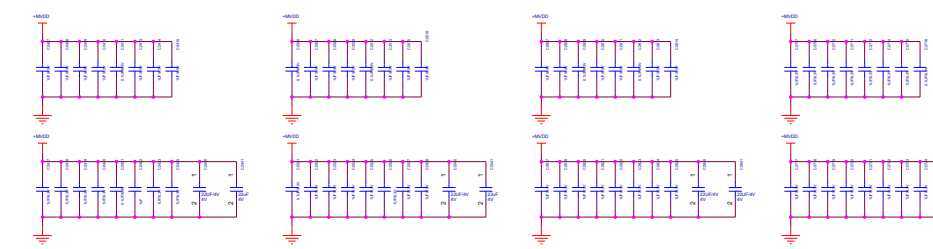
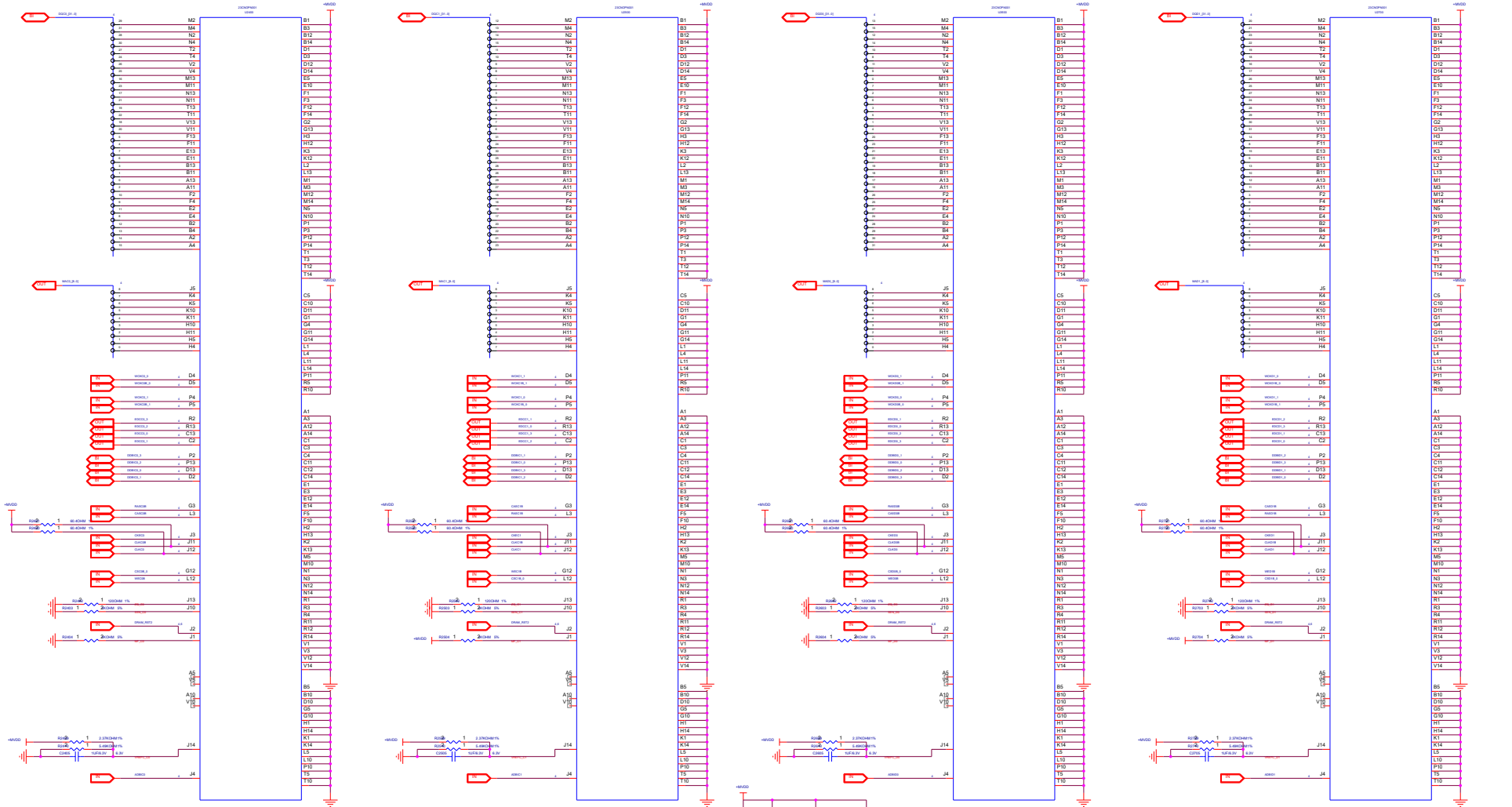

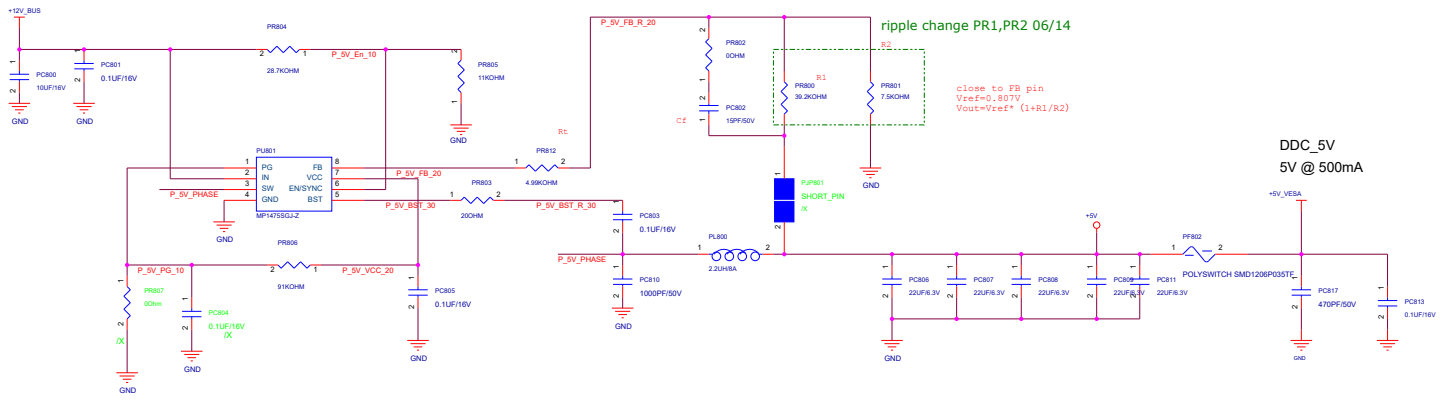

Option

