

CONFIDENTIAL

This document contains confidential material. This material cannot be shared except with persons that have a valid business reason to read this content. You are personally responsible to ensure recipients of this document are aware of information handling guidelines.

Service schematics

Lumia 950XL

RM-1085

Lumia 950XL

Dual SIM

RM-1116



IMPORTANT

This document is intended for use by authorized Microsoft service centers only. Please use the document together with other documents such as the Service Manual and Service Bulletins.

Version information

While every effort has been made to ensure that the document is accurate, some errors may exist. Please always check for the latest published version for this document.

v1.0 - 20.11.2015
-First approved version.

Contents

- 1 Front page
- 2 PM8994, MSM8994, Side key flex
- 3 MSM8994, Memory, Sensors, SIM(s), Main/Front Camera connectors, Sub PWB flex connector
- 4 MSM8994, PMI8994, Display/Touch, USB, IHF amplifier
- 5 PMI8994, Audio, Battery, Wireless Charging, Vibra
- 6 Bridge flex, Sub board flex, NFC, Iris Camera flex, Front Camera flex
- 7 WLAN/BT, FM, GNSS
- 8 RF Transceiver p1
- 9 RF Transceiver p2
- 10 Component finder Top (Board: 4QC_09r)
- 11 Component finder Bottom (Board: 4QC_09r)
- 12 Component finder Top (Board: 4RS_05d)
- 13 Component finder Bottom (Board: 4RS_05d)

This document will cover following releases:

Lumia 950XL, RM-1085, Board: 4QC_09r
Lumia 950XL Dual SIM, RM-1116, Board: 4RS_05d



Send feedback

- Recommend Change in KICS
- Rate this page in KICS
- e-mail to: mmds-trg@microsoft.com

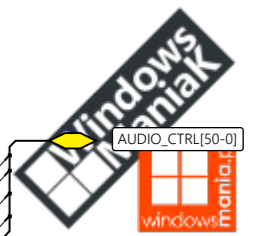
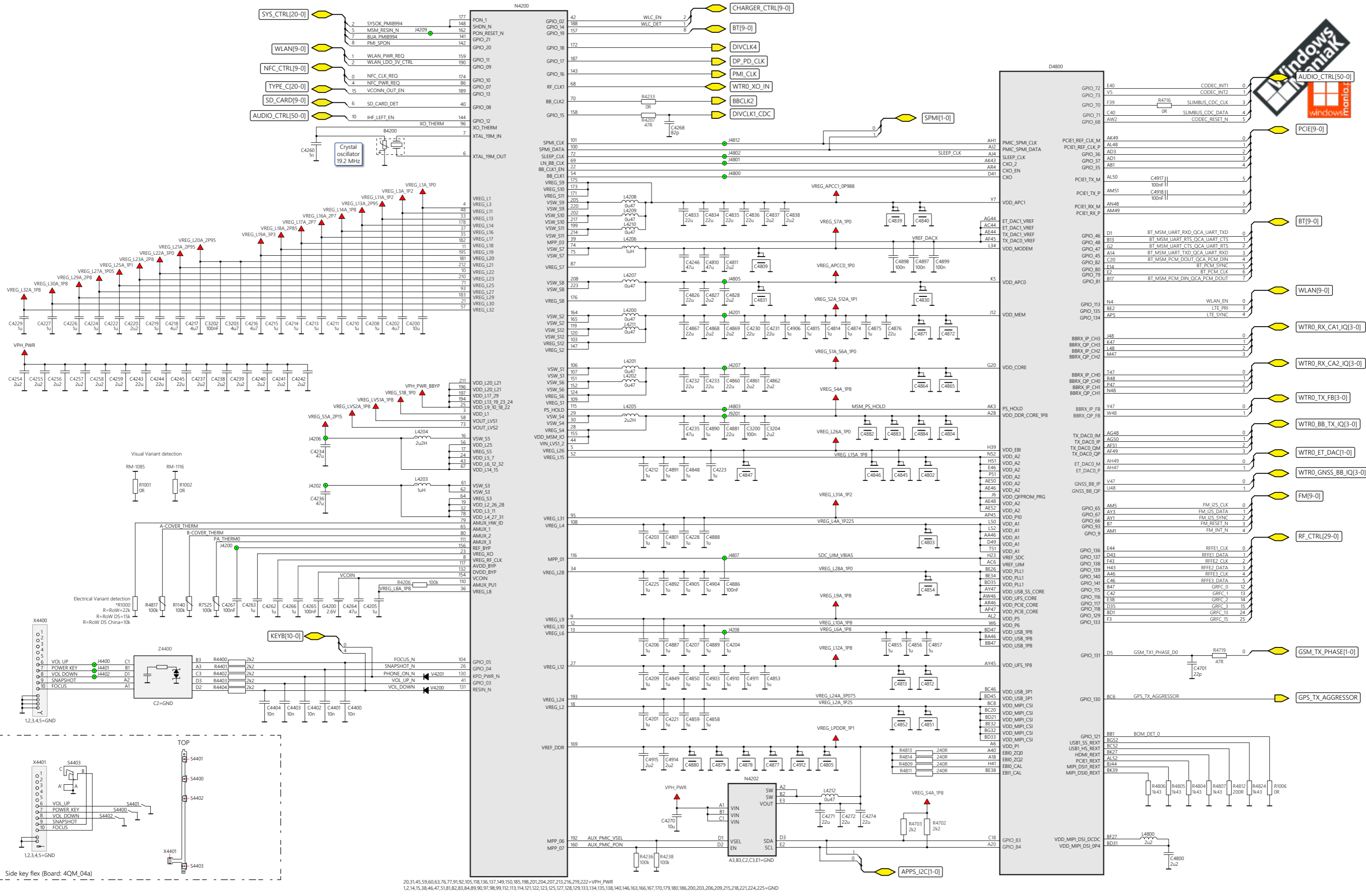

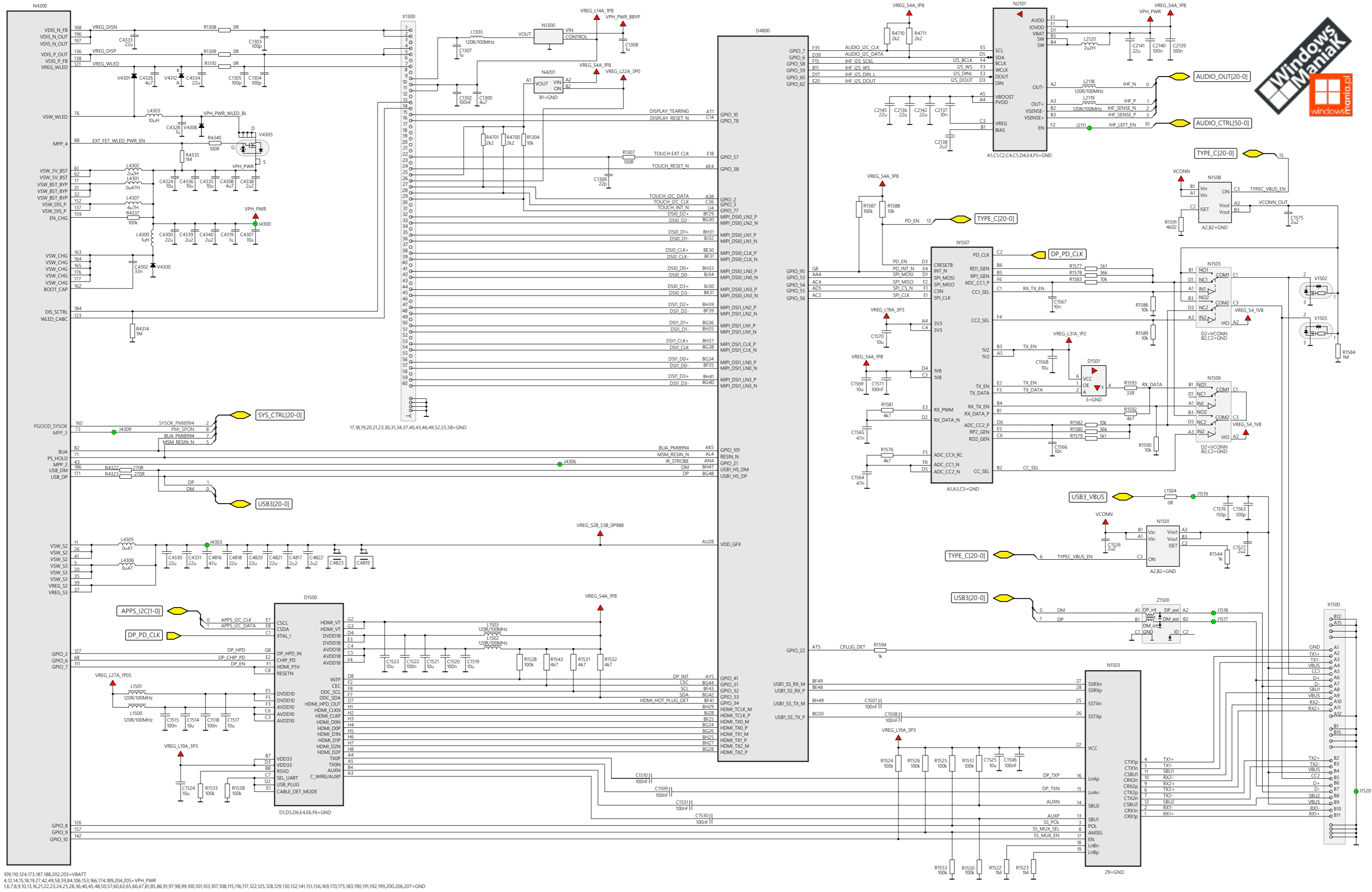

109,110,124,173,187,188,202,203=VBATT
 4,12,14,15,18,19,27,42,49,58,59,84,106,153,166,174,189,204,205=VPH_PWR
 1,6,7,8,9,10,13,16,21,22,23,24,25,28,36,40,45,46,50,57,60,63,65,66,67,81,85,86,91,97,98,99,100,101,103,107,108,115,116,117,122,125,128,129,130,132,141,151,156,169,170,175,183,190,191,192,199,200,206,207=GND

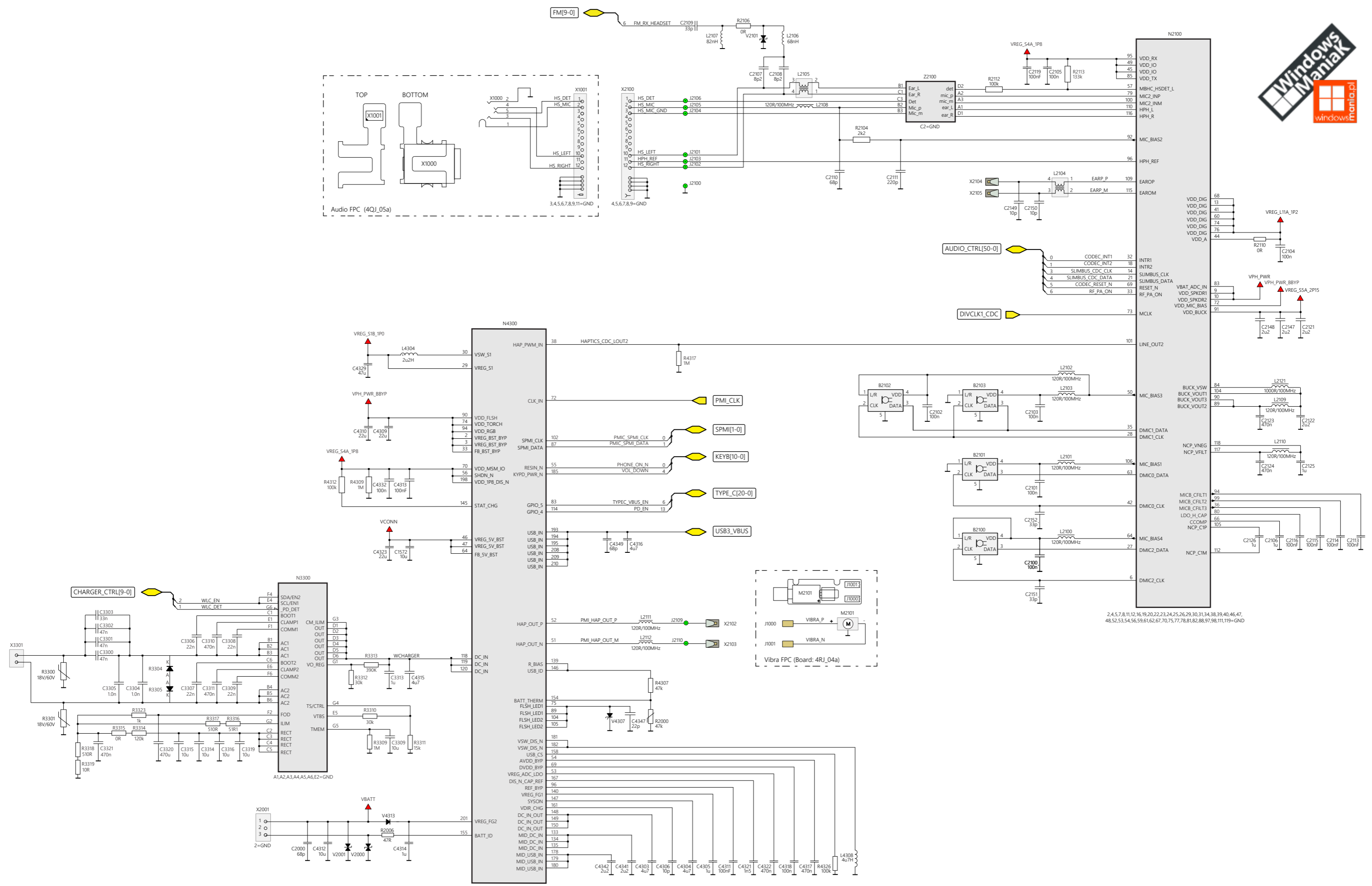

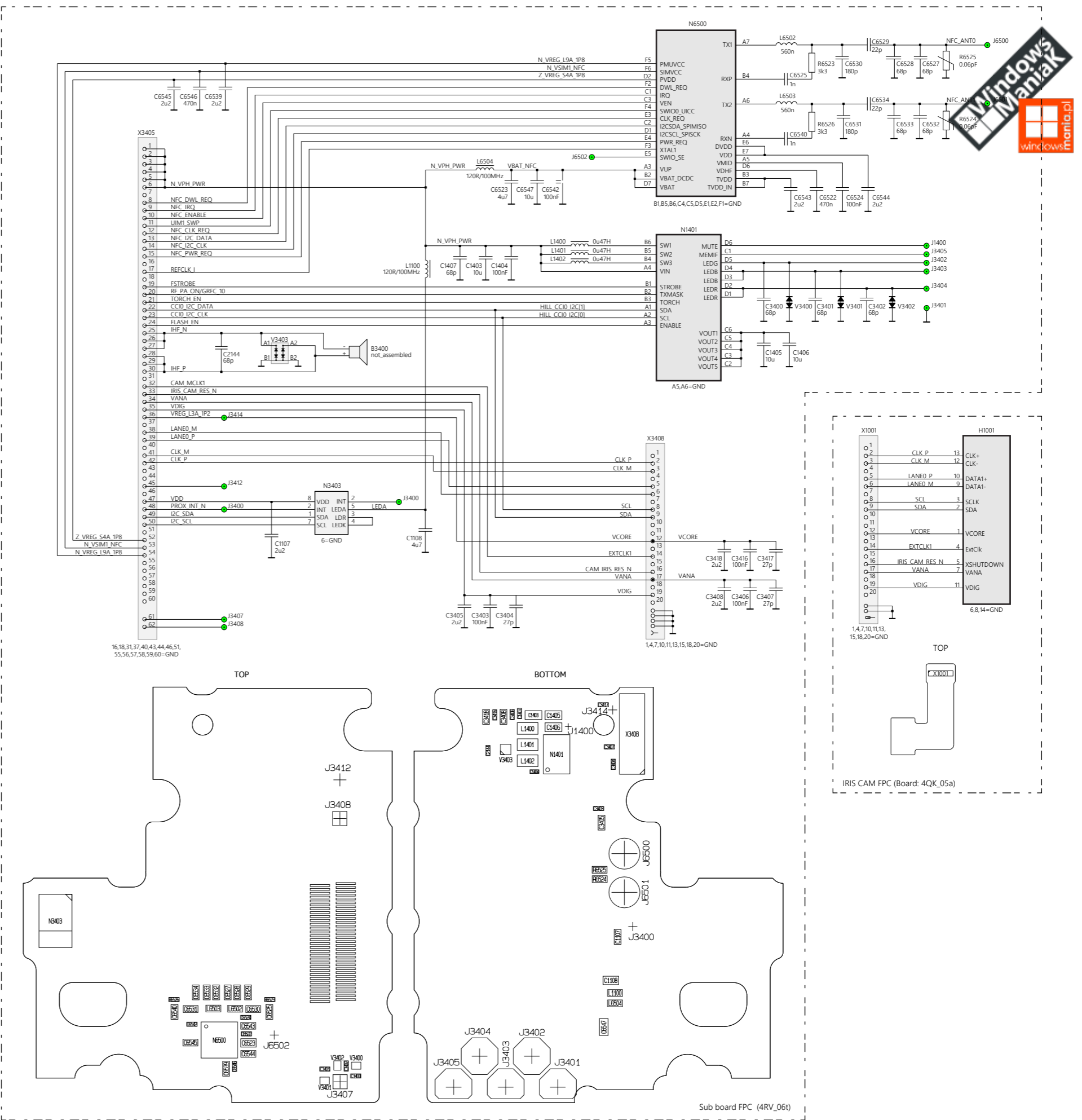
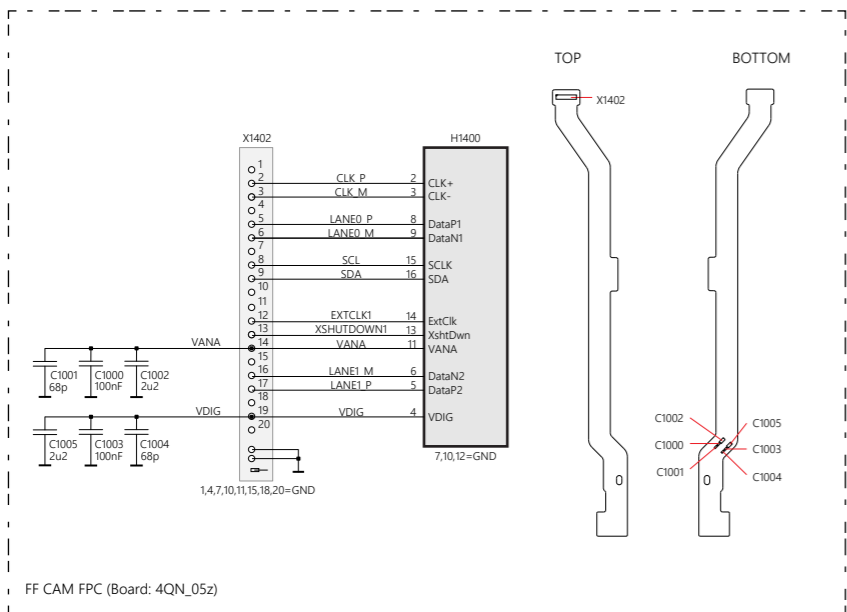
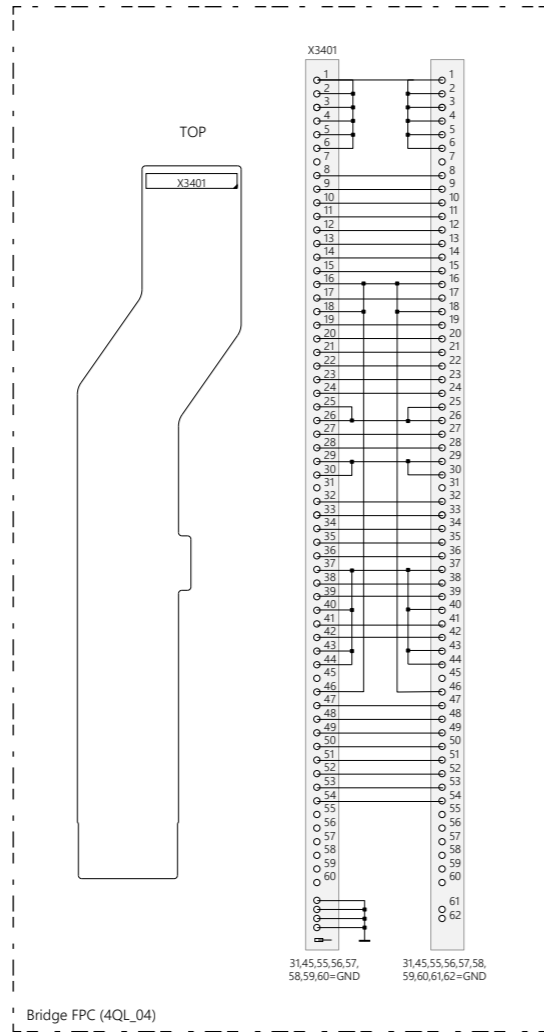

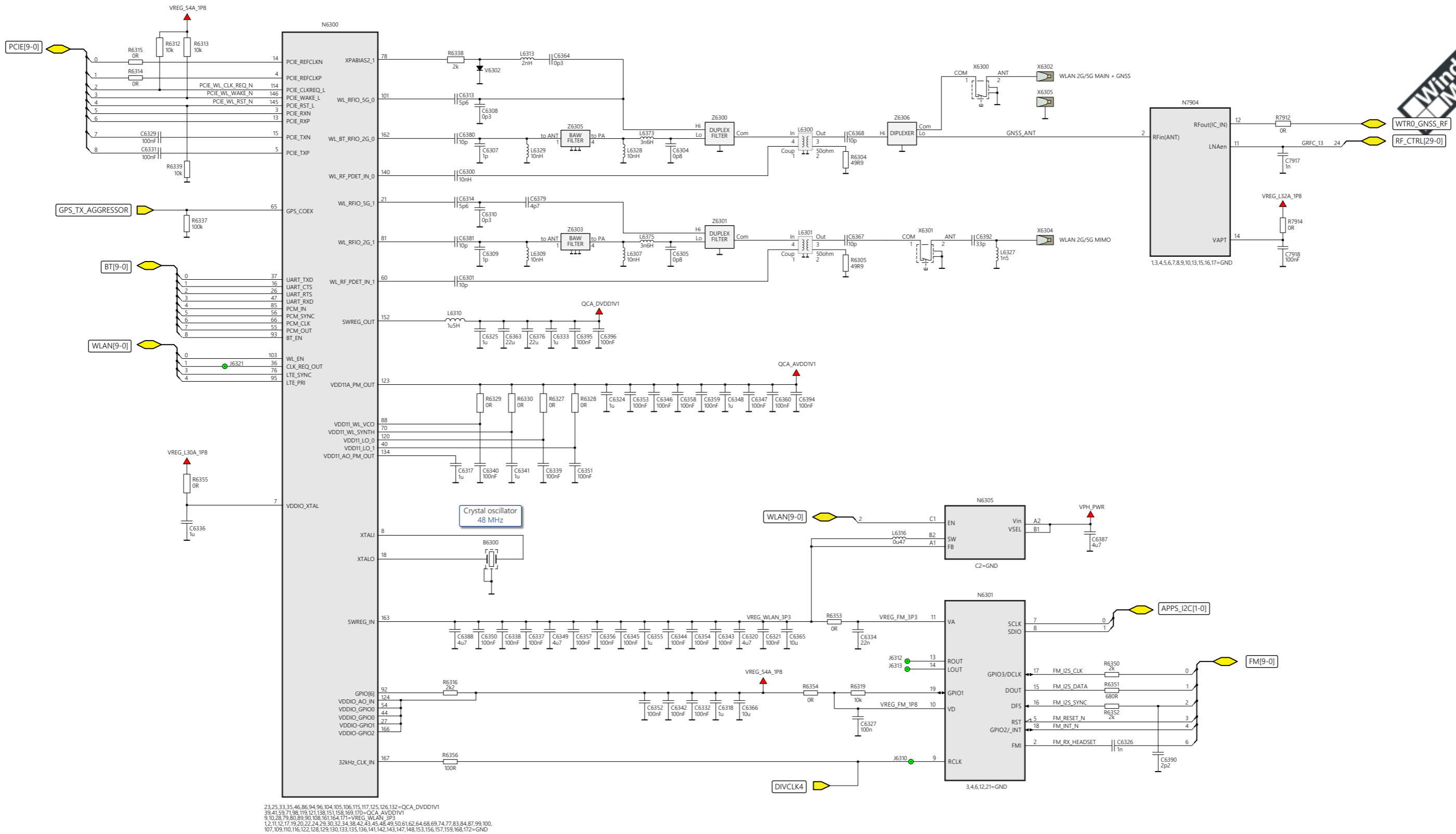

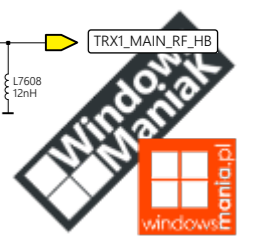
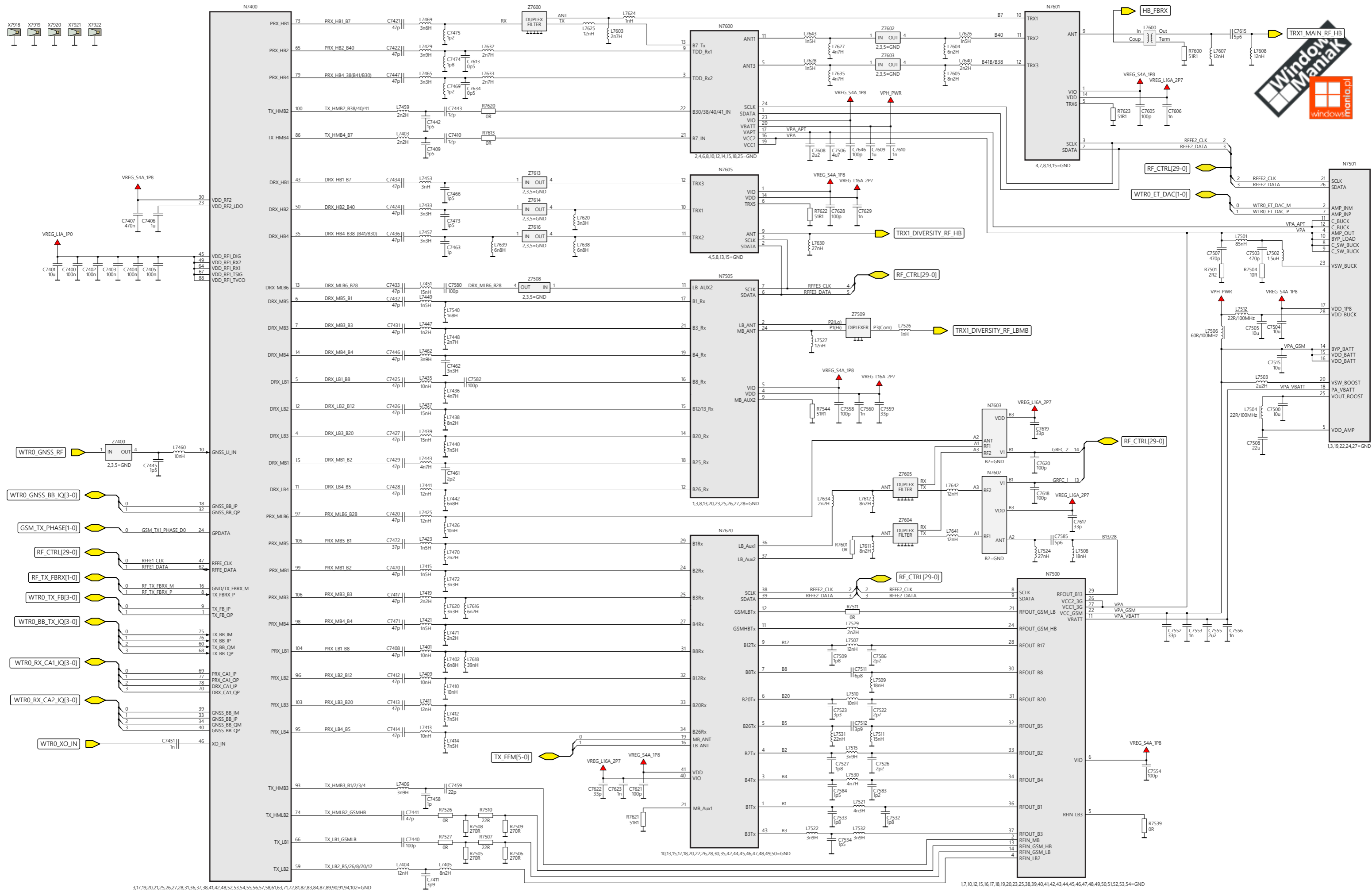

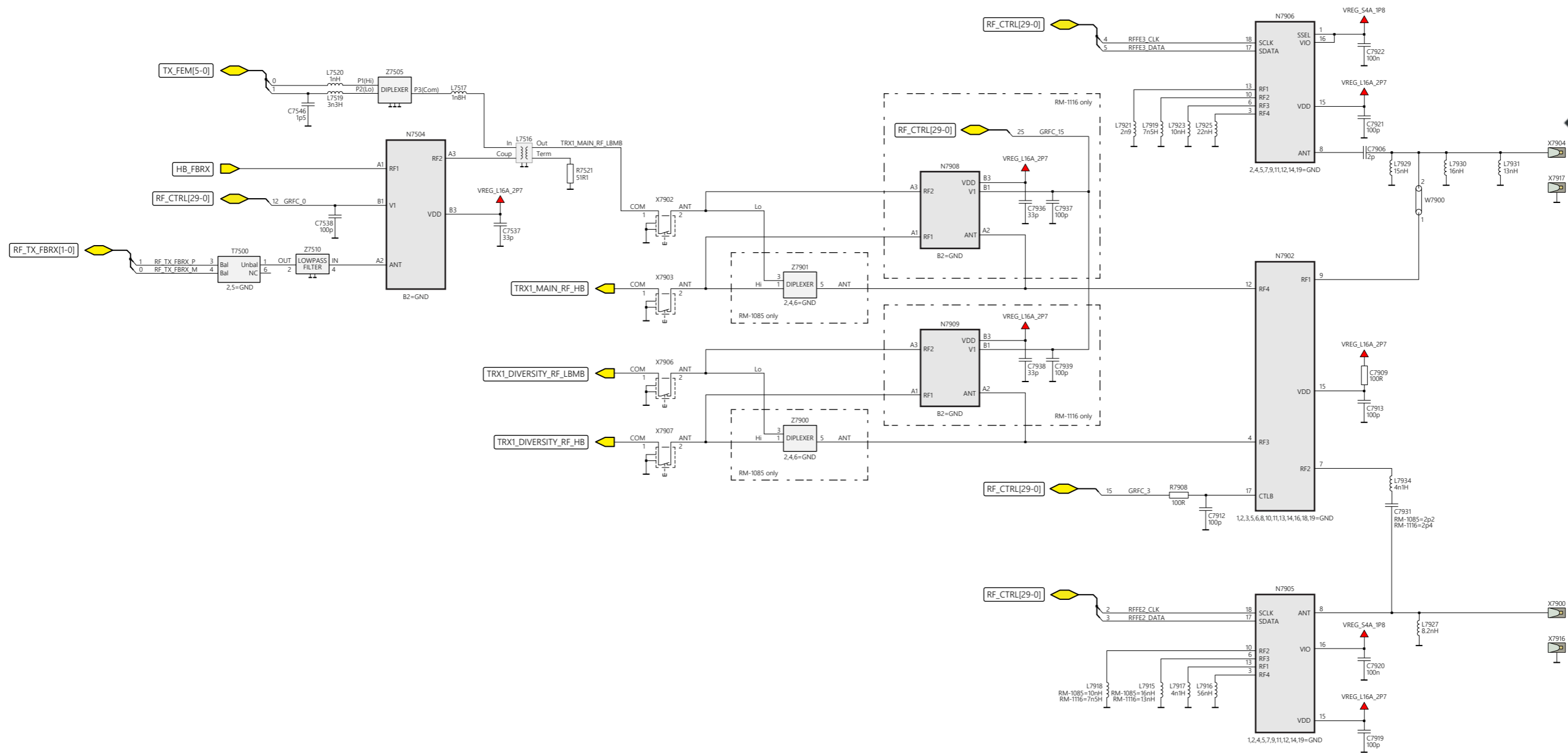

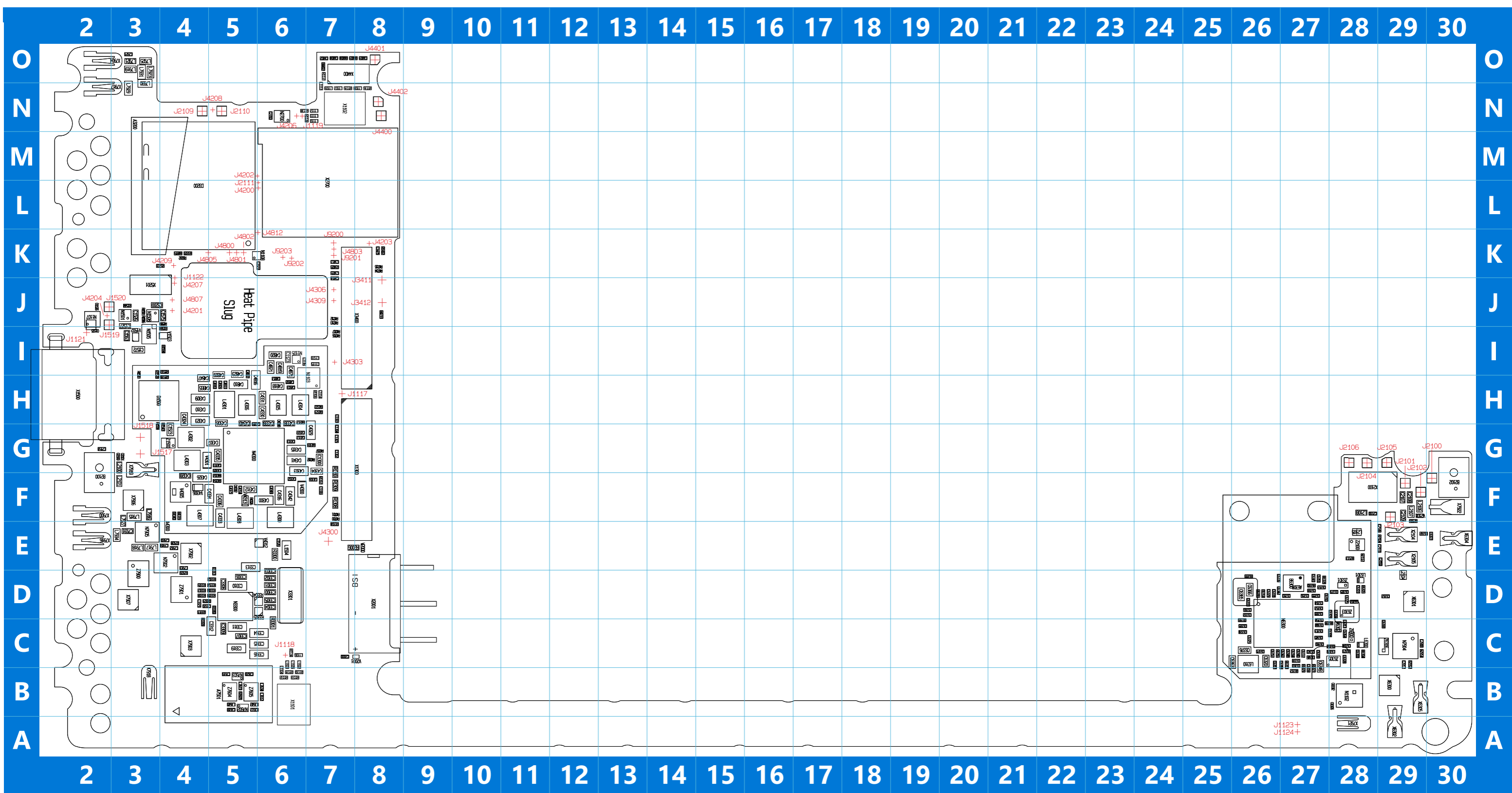

B	C1304	G7	C2111	E29	C3313	E5	C4309	H4	C4330	H6	C4811	H5	C6301	D28	C6333	D26	C6353	D27	C6392	E29	D3200	L4	L2105	E28	L6313	C28	L7925	O3	N6300	C27	R1304	E7	R2006	E7	R3316	D5	R4402	O7	R6315	D26	V2001	C8	X2700	L7	X7918	B3	J1118	C6	J2110	N5	J4401	O8	
B2100	G2	C1305	G7	C2149	E29	C3314	C6	C4310	H4	C4331	H6	C4816	H5	C6304	C28	C6336	D26	C6354	C27	C6394	C27	L	L2106	F29	L6327	E30	L7927	F3	N7602	B5	R1307	F7	R2104	E29	R3317	D4	R4403	O7	R6316	C26	V2101	F29	X3301	D6	X7919	G3	J1119	N6	J2111	L6	J4402	N8	
B2102	F30	C1306	F7	C2150	E29	C3315	C6	C4311	G5	C4332	F5	C4817	H6	C6305	D28	C6337	C27	C6355	D27	C6395	C26	L1102	C6	L2107	F29	L6328	C28	L7929	N3	N7603	B5	R1308	F7	R2106	F29	R3318	D4	R4404	O7	R6327	B27	V4300	F6	X3400	J8	X7921	A28	J1121	I2	J3411	J8	J4800	K5
B6300	D27	C1421	K8	C2151	G2	C3316	C6	C4312	F5	C4333	F5	C4818	H6	C6307	D28	C6338	C27	C6356	D27	C6396	D26	L1103	C6	L2108	F29	L6329	C28	L7930	N3	N7902	E4	R1309	F7	R2112	E28	R3319	D5	R4700	F7	R6328	D27	V4301	G4	X4400	O7	X7922	F30	J1122	J4	J3412	J8	J4801	K5
C	C1523	G4	C2700	N6	C3319	C5	C4313	G6	C4334	F5	C4819	I6	C6308	C28	C6339	C27	C6357	D27	C7617	B5	L1104	B6	L4300	F6	L6373	C28	L7931	O3	N7904	C29	R1310	G7	R2113	E28	R3323	D4	R4701	F7	R6329	B27	V4305	F4	X5201	J3	Z	J1123	A27	J4200	L6	J4802	K5		
C1106	B28	C1526	J3	C3300	D6	C3320	D4	C4314	F5	C4335	G5	C4820	I6	C6309	D28	C6340	C27	C6358	D27	C7618	B5	L1105	C6	L4301	H5	L6375	D28	L7934	E3	N7905	E3	R1402	K8	R3201	K4	R3405	K7	R4706	I7	R6330	D27	V4306	F4	X6300	B29	Z1500	G4	J1124	A27	J4201	J4	J4803	K7
C1112	B28	C1527	J3	C3301	D6	C3321	D4	C4315	G6	C4336	F5	C4821	I6	C6310	D27	C6341	D27	C6359	B27	C7619	B5	L1106	C6	L4302	G4	L7611	B5	N	R	R1528	I3	R3202	K4	R4233	J8	R4707	I7	R6338	C27	V4312	E6	X6301	D29	Z2100	E28	J1517	G3	J4202	M6	J4805	K4		
C1114	H7	C1563	I3	C3302	D6	C3413	K7	C4316	F6	C4338	H6	C4822	I5	C6313	D27	C6342	D26	C6360	C27	C7620	B5	L1107	N7	L4303	G4	L7612	B6	N1102	B28	R1106	H7	R1531	H4	R3300	E6	R4307	F5	R4712	J7	R6355	D26	V4313	F5	X6302	A29	Z6300	C28	J1518	G3	J4203	K8	J4807	J4
C1115	I7	C1572	I3	C3303	D6	C3414	J7	C4317	G6	C4339	H6	C4823	I5	C6314	D27	C6343	C27	C6363	C26	C7912	E4	L1108	N8	L4304	H6	L7634	B6	N1103	H7	R1130	B6	R1532	I4	R3301	C6	R4309	G7	R4713	J7	R6356	C26	V6302	C28	X6304	E30	Z6301	D28	J1519	J2	J4204	J2	J4812	K6
C1116	I6	C1575	J4	C3304	D6	C3415	K7	C4318	H6	C4340	H5	C4847	H4	C6317	C26	C6344	C27	C6364	C28	C7913	E4	L1109	N7	L4305	H6	L7641	B5	N1105	I6	R1131	B6	R1533	I3	R3304	D6	R4312	G7	R4714	K8	R7601	B5	X	X6305	B29	Z6303	D28	J1520	J2	J4206	N6	J9200	K7	
C1120	I7	C1576	E6	C3305	D6	C4300	F6	C4319	G5	C4341	G6	C4865	H4	C6318	C27	C6345	C27	C6365	D26	C7917	C29	L1110	N7	L4306	H5	L7642	B5	N1107	J2	R1132	B6	R1538	G3	R3305	D6	R4314	F5	R4715	K8	R7908	E4	X1101	B6	X7900	F2	Z6305	C28	J2100	F30	J4207	J4	J9201	K7
C1123	I6	C2000	C7	C3306	D5	C4302	F6	C4321	F5	C4342	F6	C4871	I6	C6320	C26	C6346	C27	C6366	D26	C7918	C29	L1111	N7	L4307	F4	L7915	F3	N1108	K5	R1133	B6	R1543	G4	R3309	C4	R4317	H6	R4815	K4	R7909	D4	X1102	N7	X7902	E4	Z6306	C29	J2101	F29	J4208	N5	J9202	K6
C1125	I2	C2100	G3	C3307	C5	C4303	G6	C4322	G6	C4349	F6	C4892	H6	C6321	C26	C6347	C27	C6367	D29	C7919	E4	L1112	N7	L4308	F5	L7916	F3	N1501	J3	R1134	C6	R1544	J3	R3310	D5	R4322	H7	R5201	K4	R7912	C29	X1300	G8	X7903	C4	Z7604	B5	J2102	F29	J4209	K4	J9203	K6
C1126	J2	C2101	G3	C3308	D5	C4304	G7	C4323	H4	C4402	O7	C4903	H6	C6324	C26	C6348	C27	C6368	C29	C7920	E4	L1113	N7	L6300	C28	L7917	E3	N1505	I3	R1135	N7	R1584	I4	R3311	D4	R4323	H7	R6304	C28	R7914	C29	X1500	H2	X7904	O2	Z7605	B5	J2103	F29	J4300	E7		
C1127	K6	C2107	F29	C3309	C5	C4305	G5	C4324	H4	C4403	O8	C4906	H5	C6325	C26	C6349	C27	C6369	C26	C7921	O3	L1504	E6	L6301	D28	L7918	E3	N1508	J3	R1136	N8	R1586	J3	R3312	D5	R4326	F5	R6305	D28	V	X2001	D8	X7906	F3	Z7900	D3	J2104	G28	J4303	I7			
C1300	G7	C2108	F29	C3310	D5	C4306	F7	C4326	F4	C4404	O7	C4910	H5	C6329	D26	C6350	D27	C6379	D28	C7931	E3	L2100	G3	L6307	D28	L7919	O3	N2700	N6	R1137	O7	R1589	J4	R3313	D5	R4335	F4	R6312	B27	V1502	I3	X2100	F28	X7907	D3	Z7901	D4	J2105	G29	J4306	J7		
C1302	G7	C2109	F29	C3311	C5	C4307	G5	C4328	F4	C4809	I5	C5200	J3	C6331	D26	C6351	D27	C6380	C27	D	L2101	F3	L6309	D28	L7921	O3	N3300	D5	R1138	N6	R1591	J3	R3314	D5	R4337	G7	R6313	C27	V1503	I4	X2104	E29	X7916	E2	TST points	J2106	G28	J4309	J7				
C1303	H7	C2110	F28	C3312	C5	C4308	H5	C4329	G7	C4810	H5	C6300	C28	C6332	D26	C6352	C26	C6381	D27	D1500	H3	L2104	D29	L6310	C26	L7923	O3	N4300	G5	R1139	N7	R1594	I4	R3315	D4	R4340	F4	R6314	D26	V2000	E8	X2105	E29	X7917	N2	J1117	H7	J2109	N4	J4400	N8		

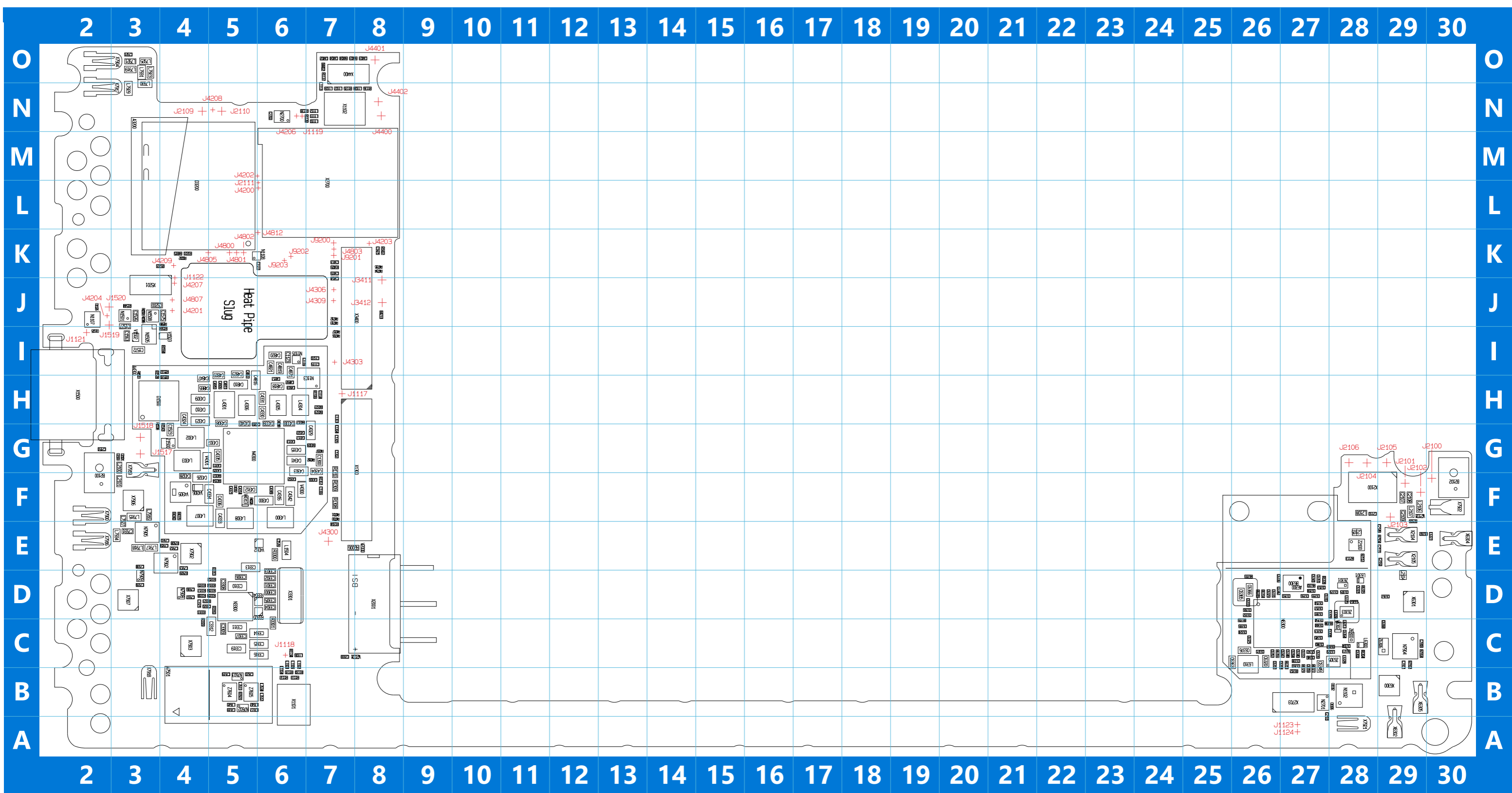

B	C1304	G7	C2111	E29	C3312	C5	C4308	H5	C4329	G7	C4810	H5	C6300	C28	C6332	D26	C6352	C26	C6381	D27	C7937	D4	L1113	N7	L6300	C28	L7917	E3	N1505	I3	R1132	B6	R1538	G3	R3305	D6	R4314	F5	R4715	K8	R7908	E4	X1101	B6	X6305	B29	Z6303	D28	J2101	F29	J4207	J4	J9201	K7	
B2100	G2	C1305	G7	C2149	E29	C3313	C5	C4309	H4	C4330	H6	C4811	H5	C6301	D28	C6333	D26	C6353	D27	C6392	E29	C7938	E3	L1504	E6	L6301	D28	L7918	E3	N1508	J3	R1133	B6	R1543	G4	R3309	C4	R4317	H6	R4815	K4	R7909	D4	X1102	N7	X7900	F2	Z6305	C28	J2102	F29	J4208	N5	J9202	K6
B2102	F30	C1306	F7	C2150	E29	C3314	C6	C4310	H4	C4331	H6	C4816	H5	C6304	D28	C6336	D26	C6354	C27	C6394	C27	C7939	D3	L2100	G3	L6307	D28	L7919	O3	N2700	N6	R1134	C6	R1544	J3	R3310	D5	R4322	H7	R5201	K4	R7912	C29	X1300	G8	X7902	E4	Z6306	C29	J2103	F29	J4209	K4	J9203	K6
B6300	D27	C1421	K8	C2151	G2	C3315	C6	C4311	G5	C4332	F5	C4817	H6	C6305	D28	C6337	C27	C6355	D27	C6395	C26	D	L2101	F3	L6309	D28	L7921	O3	N2701	B27	R1135	N7	R1584	I4	R3311	D4	R4323	H7	R6304	C28	R7914	C29	X1500	H2	X7903	C4	Z7604	B5	J2104	G28	J4300	E7			
C	C1523	G4	C2700	N6	C3316	C6	C4312	F5	C4333	F5	C4818	H6	C6307	C28	C6338	C27	C6356	D27	C6396	D26	D1500	H3	L2104	D29	L6310	C26	L7923	O3	N3300	D5	R1136	N8	R1586	J3	R3312	D5	R4326	F5	R6305	D28	V	X2001	D8	X7904	O2	Z7605	B5	J2105	G29	J4303	I7				
C1106	B28	C1526	J3	C2701	B27	C3319	C5	C4313	G6	C4334	F5	C4819	I6	C6308	C28	C6339	C27	C6357	D27	C7617	B5	D3200	L4	L2105	E28	L6313	C28	L7925	O3	N4300	G5	R1137	O7	R1589	J4	R3313	D5	R4335	F4	R6312	B27	V1502	I3	X2100	F28	X7906	F3	TST points	J2106	G28	J4306	J7			
C1112	B28	C1527	J3	C3300	D6	C3320	D4	C4314	F5	C4335	G5	C4820	I6	C6309	D28	C6340	C27	C6358	D27	C7618	B5	L	L2106	F29	L6327	E30	L7927	F3	N6300	C27	R1138	N6	R1591	J3	R3314	D5	R4337	G7	R6313	C27	V1503	I4	X2104	E29	X7907	D3	J1117	H7	J2109	N4	J4309	J7			
C1114	H7	C1563	I3	C3301	D6	C3321	D4	C4315	G6	C4336	F5	C4821	I6	C6310	D27	C6341	D27	C6359	B27	C7619	B5	L1102	C6	L2107	F29	L6328	C28	L7929	N3	N7602	B5	R1139	N7	R1594	I4	R3315	D4	R4340	F4	R6314	D26	V2000	E8	X2105	E29	X7916	E2	J1118	C6	J2110	N5	J4400	N8		
C1115	I7	C1572	I3	C3302	D6	C3413	K7	C4316	F6	C4338	H6	C4822	I5	C6313	C27	C6342	D26	C6360	C27	C7620	B5	L1103	C6	L2108	F28	L6329	C28	L7930	N3	N7603	B5	R1304	E7	R2006	E7	R3316	D5	R4402	O7	R6315	D26	V2001	C8	X2700	L7	X7917	N2	J1119	N6	J2111	L6	J4401	O8		
C1116	I6	C1575	J4	C3303	D6	C3414	J7	C4317	G6	C4339	H6	C4823	I5	C6314	D27	C6343	C27	C6363	C26	C7912	E4	L1104	B6	L4300	F6	L6373	C28	L7931	O3	N7902	E4	R1307	F7	R2104	E29	R3317	D4	R4403	O7	R6316	C26	V2101	F29	X2703	B27	X7918	B3	J1121	I2	J2700	B27	J4402	N8		
C1120	I7	C1576	E6	C3304	D6	C3415	K7	C4318	H6	C4340	H6	C4847	H4	C6317	C26	C6344	C27	C6364	C28	C7913	E4	L1105	C6	L4301	H5	L6375	D28	L7934	E3	N7904	C29	R1308	F7	R2106	F29	R3318	D4	R4404	O7	R6327	B27	V4300	F6	X3301	D6	X7919	G3	J1122	J4	J3411	J8	J4800	K5		
C1123	I6	C2000	C7	C3305	D6	C4300	F6	C4319	G5	C4341	G6	C4865	H4	C6318	C27	C6345	C27	C6365	D26	C7917	C29	L1106	C6	L4302	G4	L7611	B5	N	N7905	E3	R1309	F7	R2112	E28	R3319	D5	R4700	F7	R6328	D27	V4301	G4	X3400	J8	X7921	A28	J1123	A27	J3412	J8	J4801	K5			
C1125	I2	C2100	G3	C3306	D5	C4302	F6	C4321	F5	C4342	F6	C4871	I6	C6320	C26	C6346	C27	C6366	D26	C7918	C29	L1107	N7	L4303	G4	L7612	B6	N1102	B28	N7908	D4	R1310	G7	R2113	E28	R3323	D4	R4701	F7	R6329	B27	V4305	F4	X4400	O7	X7922	F30	J1124	A27	J4200	L6	J4802	K5		
C1126	J2	C2101	G3	C3307	C5	C4303	G6	C4322	G6	C4349	F6	C4892	H6	C6321	C26	C6347	C27	C6367	D29	C7919	E4	L1108	N8	L4304	H6	L7634	B6	N1103	H7	N7909	D3	R1310	K8	R3201	K4	R3405	K7	R4706	I7	R6330	D27	V4306	F4	X5201	J3	Z	J1517	G3	J4201	J4	J4803	K7			
C1127	K6	C2107	F29	C3308	D5	C4304	G7	C4323	H4	C4402	O7	C4903	H6	C6324	C26	C6348	C27	C6368	C29	C7920	E4	L1109	N7	L4305	H6	L7641	B5	N1105	I6	R	R1528	I3	R3202	K4	R4233	J8	R4707	I7	R6338	C27	V4312	E6	X6300	B29	Z1500	G4	J1518	G3	J4202	M6	J4805	K4			
C1300	G7	C2108	F29	C3309	C5	C4305	G5	C4324	H4	C4403	O8	C4906	H5	C6325	C26	C6349	D27	C6376	C28	C7921	O3	L1110	N7	L4306	H5	L7642	B5	N1107	J2	R1106	H7	R1531	H4	R3300	E6	R4307	F5	R4712	J7	R6355	D26	V4313	F5	X6301	D29	Z2100	E28	J1519	J2	J4203	K8	J4807	J4		
C1302	G7	C2109	F29	C3310	D5	C4306	F7	C4326	F4	C4404	O7	C4910	H5	C6329	D26	C6350	D27	C6379	D28	C7931	E3	L1111	N7	L4307	F4	L7915	F3	N1108	K5	R1130	B6	R1532	I4	R3301	C6	R4309	G7	R4713	J7	R6356	C26	V6302	C28	X6302	A29	Z6300	C28	J1520	J2	J4204	J2	J4812	K6		
C1303	H7	C2110	F28	C3311	C5	C4307	G5	C4328	F4	C4809	I5	C5200	J3	C6331	D26	C6351	D27	C6380	C27	C7936	D4	L1112	N7	L4308	F5	L7916	F3	N1501	J3	R1131	B6	R1533	I3	R3304	D6	R4312	G7	R4714	K8	R7601	B5	X	X6304	E30	Z6301	D28	J2100	F30	J4206	N6	J9200	K7			